

# PATROL SOUNDERS 110/120 dB(A)

## PA 10 / PA 20



PATROL - the new generation of sounders.

Three dimensional innovation;

- safe; an incorrect installation is virtually impossible
- easy; significantly shorter assembly and installation times
- economical; extremely high efficiency and good penetration of acoustical obstacles significantly reduce the required number of sounders



reddot design award winner 2013

<b>PA 10</b> max. covering distance 56 m	<b>PA 20</b> max. covering distance 178 m	<b>IP 66</b> Protection system	<b>IK 08</b> Impact-proof housing	<b>+ 55 °C</b> <b>- 40 °C</b> Operating temperature	Acoustic penetration	<b>EN 54-3</b> 24-48 V DC 115-230 V AC	<b>VdS</b> 24-48 V DC 115-230 V AC	<b>UL</b>	<b>10 Years</b> Warranty
--	---	-----------------------------------	--------------------------------------	---	----------------------	--	--	-----------	-----------------------------

Electrical data	PA 10		
Rated voltage	95 – 265 V AC	24 V AC	10 – 60 V DC
Rated frequency	50 / 60 Hz	50 / 60 Hz	
Operating range	95 – 265 V	20 – 30 V	10 – 60 V
Nominal current consumption	20 – 115 mA	250 – 900 mA	60 – 485 mA
Electrical data	PA 20		
Rated voltage	95 – 265 V AC	24 V AC	10 – 60 V DC
Rated frequency	50 / 60 Hz	50 / 60 Hz	
Operating range	95 – 265 V	20 – 30 V	10 – 60 V
Nominal current consumption <sup>1</sup>	75 – 330 mA	500 – 1,800 mA	120 – 880 mA

<sup>1</sup> power consumption dependent on operating voltage

Mechanical data	PA 10	PA 20
Sound pressure level	110 dB (A)	120 dB (A)
Sound level reduction	max. - 12 dB via potentiometer	
Alarm tones	80 (see tone table page 140/141)	
Duty cycle	100%	
Operating temperature	- 40 °C ... + 55 °C	
Storage temperature	- 40 °C ... + 70 °C	
Relative humidity	90%	
Protection system according to EN 60529	IP 66	
Protection class	II	
Material	PC / ABS blend	
Colour	similar to RAL 3000 (flame red) / RAL 7035 (light grey) / RAL 9003 (signal white)	
Cable entry	5 x M20 knock-outs on side, 1 knock-out on back	
Integrated seal with cable entry	6 – 13 mm (feed-through grommet)	
Connecting terminals	2.5 mm <sup>2</sup> fine wire with cable end sleeve, AWG 16	
Weight	AC	1,060 g
	DC	1,050 g

### Dimensions

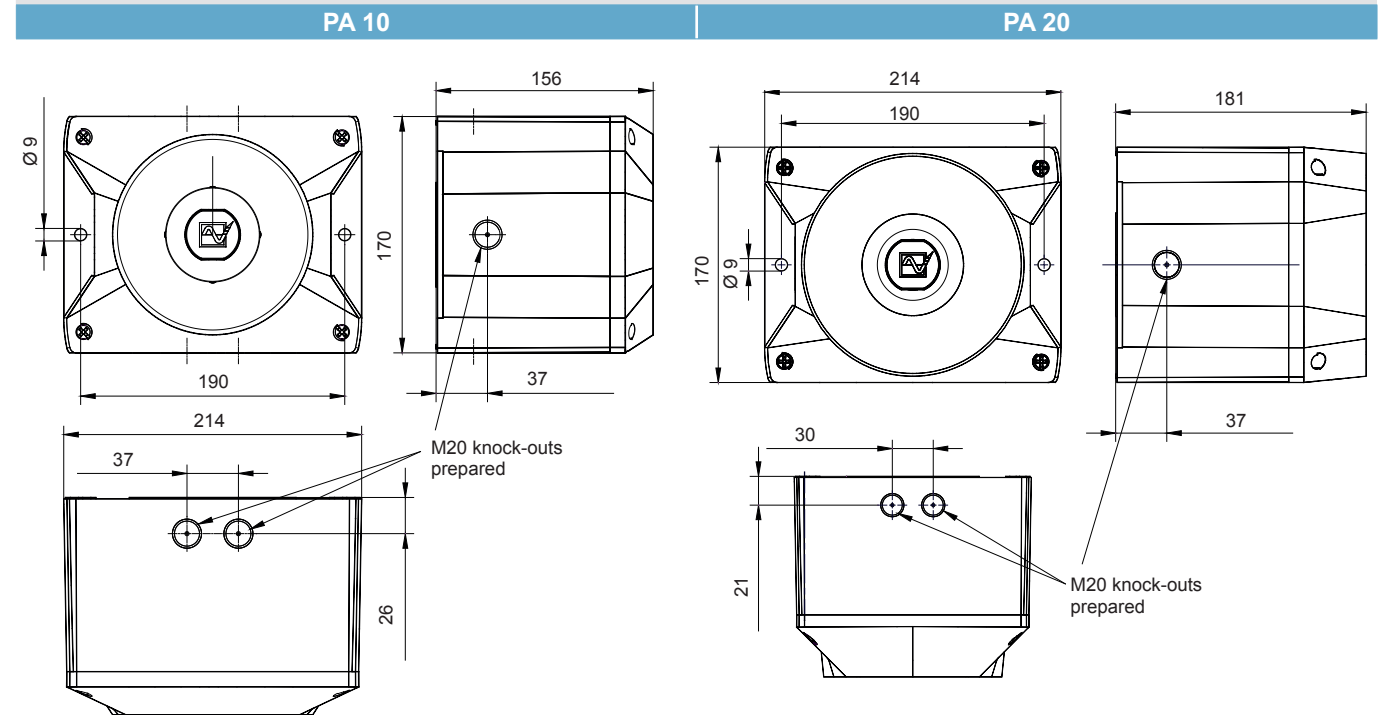

### Ordering details

Article numbers		PA 10			PA 20		
Version	Rated voltage	95-265 V AC	24 V AC	10-60 V DC	95-265 V AC	24 V AC	10-60 V DC
Standard	housing red	233 60 64 0 000	233 60 30 0 000	233 60 63 0 000	233 70 64 0 000	233 70 30 0 000	233 70 63 0 000
GL/MED	housing red	233 60 64 0 001	233 60 30 0 001	233 60 63 0 001	233 70 64 0 001	233 70 30 0 001	233 70 63 0 001
Standard	housing grey	233 60 64 0 055	233 60 30 0 055	233 60 63 0 055	233 70 64 0 055	233 70 30 0 055	233 70 63 0 055
GL/MED	housing grey	233 60 64 0 056	233 60 30 0 056	233 60 63 0 056	233 70 64 0 056	233 70 30 0 056	233 70 63 0 056

Article numbers for other voltages and versions on request

### Options / Accessories

GL	MED	CNBOP	Enclosure fitting	Surface gasket	Tamper-proof sealing	Panel mounting kit	SSM (only for 24 V DC)
----	-----	-------	-------------------	----------------	----------------------	--------------------	------------------------

See page 141 for further information

### Conformity to standards

The acoustic parameters conform to the European standard DIN EN ISO 7731; "Ergonomic – alarm signals for public areas and workplaces – acoustic alarm signals".

The requirement for an acoustic alarm signal can be found in the harmonised standards:  
 EN 60204-1 Electrical equipment of machines  
 EN 60825-1 Radiation safety of laser devices, identical to IEC 825 and DIN-VDE 0837

Tone table PA 1 / PA 5 / PA 10 / PA 20

Tone	Description	Tone	Description
1	no tone	69	Continuous tone
2	Sawtooth, DIN tone 33404-3 Germany (emergency signal), PFEER PTAP	71	Continuous tone
9	Slow whoop, fire alarm, UK BS5839-1	77	Interrupted tone
11	Interrupted tone (fast)	82	Interrupted tone, PFEER (general alarm), UK BS5839-1 (back-up alarm)
13	Interrupted tone	83	Interrupted tone, PFEER (general alarm)
15	Slow whoop, evacuation alarm Netherlands NEN 2575	88	Interrupted tone
16	Slow whoop, Australian evacuation alarm AS2220	90	Interrupted tone
18	Slow whoop, NFPA	91	Interrupted tone
22	Pulsating tone, Australien alert AS1670, ISO8201	92	Interrupted tone
23	Siren	93	Interrupted tone (fast), horn
24	Siren	97	Interrupted tone
25	Siren	98	Interrupted tone, Sweden SS031711 (emergency signal)
26	Pulsating tone, industrial alarm Germany	100	Interrupted tone, industrial alarm Germany
27	Sweeping	101	Interrupted tone, Sweden SS031711 (important message (pre-mess))
29	Sweeping (fast)	102	Interrupted tone, Sweden SS031711 (local warning)
30	Sweeping	103	Interrupted tone, Sweden SS031711 (air raid warning)
31	Sweeping, France NFC48-265	104	Interrupted tone, Sweden SS031711 (emergency signal)
33	Sweeping (medium), UK BS5839-1	107	Interrupted tone, Germany KTA3901 (evacuation alarm)
34	Sweeping (fast)	109	Interrupted tone, Australia AS2220, AS1610, AS1670
35	Sweeping (fast), UK BS5839-1	110	Interrupted tone, (fast variable), bell
36	Sweeping	111	Interrupted tone, ISO8201 (emergency evacuation signal), USA (evacuation alarm)
43	Sweeping	112	Interrupted tone, ISO8201 (emergency evacuation signal)
44	Sweeping, IMO 3d, Germany KTA3901 evacuation alarm	113	Interrupted tone, ISO8201 (emergency evacuation signal), Sweeping
45	Sweeping	115	Interrupted tone, IMO (telephone call)
46	Sweeping, general alarm Finland	116	Interrupted tone, IMO (leave ship)
52	Continuous tone	117	Interrupted tone, IMO SOLAS III/50 + SOLAS III/6.4 (general alarm)
53	Continuous tone	122	Alternating tone
54	Continuous tone, Finland (all-clear signal)	123	Alternating tone
55	Continuous tone, PFEER gasalarm	124	Alternating tone, Singapore
56	Continuous tone	125	Alternating tone
57	Continuous tone, UK BS5839-1	128	Alternating tone
59	Continuous tone	130	Alternating tone, UK BS5839-1 (fire alarm)
60	Continuous tone	131	Alternating tone, UK BS5839-1 (fire alarm, railway crossing)
61	Continuous tone	135	Alternating tone, UK BS5839-1 (fire alarm, increased urgency - railway crossing)
63	Continuous tone	142	Alternating tone
65	Continuous tone, Sweden SS031711 (all-clear signal)		
66	Continuous tone		
67	Continuous tone, Germany KTA3901 (all-clear signal)		
68	Continuous tone		

Tone table PA 1 / PA 5 / PA 10 / PA 20

Tone	Description	Tone	Description
143	Alternating tone, industrial alarm Germany	147	Alternating tone, Sweden SS031711
144	Alternating tone	148	Alternating tone, Sweden SS031711
146	Alternating tone, France NFS 32-001 (fire alarm)	152	Alternating tone (two tone chime)

Control of the tones

Tone selection switch/DIP-Switch (setting of basic tone)							External tone selection			Tone selection switch/DIP-Switch (setting of basic tone)							External tone selection		
1	2	3	4	5	6	Tone	C1	C2	C1+C2	1	2	3	4	5	6	Tone	C1	C2	C1+C2
							Tone no.										Tone no.		
						1			2							71	131	52	93
ON						2 *	128	112	57	ON						77	61	52	122
	ON					2	26	100	93		ON					82	131	52	83
ON	ON					2	61	131	112	ON	ON					83	56	2	82
		ON				9	57	11	82			ON				88	2	57	128
ON		ON				15	131	52	112	ON		ON				90	131	52	125
			ON			16	109	52	56		ON	ON				91	30	52	110
ON	ON	ON				18	111	57	68	ON	ON	ON				92	33	52	57
				ON		22	16	109	68				ON			93	2	128	57
ON			ON			23	131	52	112	ON			ON			97	2	63	93
	ON					24	131	52	131		ON		ON			100	131	52	125
ON	ON		ON			25	131	52	92	ON	ON		ON			101	98	102	65
		ON	ON			26	2	100	93			ON	ON			103	131	65	147
ON		ON	ON			27	123	52	92	ON		ON	ON			104	103	65	101
				ON		29	35	52	61		ON	ON	ON			109	16	52	22
ON	ON	ON				30	27	52	77	ON	ON	ON	ON			110	131	61	91
					ON	31	131	52	57					ON	ON	112	2	57	128
ON				ON		33	30	52	35	ON				ON	ON	113	52	123	104
	ON			ON		34	35	52	93		ON			ON	ON	115	117	116	44
ON	ON		ON			35	27	52	110	ON	ON			ON	ON	116	117	93	125
		ON	ON			36	146	67	57			ON		ON	ON	117	93	116	125
ON		ON	ON			43	131	52	91	ON		ON		ON	ON	123	27	52	77
	ON	ON		ON		45	2	57	93		ON	ON		ON	ON	124	53	83	2
ON	ON	ON		ON		52	15	65	82	ON	ON	ON		ON	ON	130	2	107	67
					ON	54	46	54	131				ON	ON	ON	131	2	112	57
ON			ON	ON		55	131	52	128	ON			ON	ON	ON	135	16	56	109
	ON		ON	ON		56	82	35	33		ON		ON	ON	ON	142	2	54	88
ON	ON		ON	ON		59	143	59	101	ON	ON		ON	ON	ON	143	59	93	33
					ON	60	131	52	125			ON	ON	ON	ON	144	110	61	2
ON		ON	ON	ON		65	131	52	93	ON		ON	ON	ON	ON	146	31	67	57
	ON	ON	ON	ON		66	110	52	107		ON	ON	ON	ON	ON	148	131	52	92
ON	ON	ON	ON	ON		69	131	52	110	ON	ON	ON	ON	ON	ON	152	110	61	13

\* factory setting

ACCESSORIES

Ordering details

Article numbers	PA 1	PA 5	PA 10 / PA 20
Enclosure fitting	For connection (daisy-chaining) of several sounders of the PATROL series		
Surface gasket	Sealing of the sounder installation surface when, e.g. cable entry is executed from the back.		
Tamper-proof sealing (pack of 4)	Anti-tamper sealing for fasteners of the PATROL devices after installation in order to prevent manipulation of the devices.		
Panel mount installation kit PATROL	The PATROL devices are also suitable for panel mounting. This kit consists of a plug connector for the electrical contact, as well as all installation materials.		