

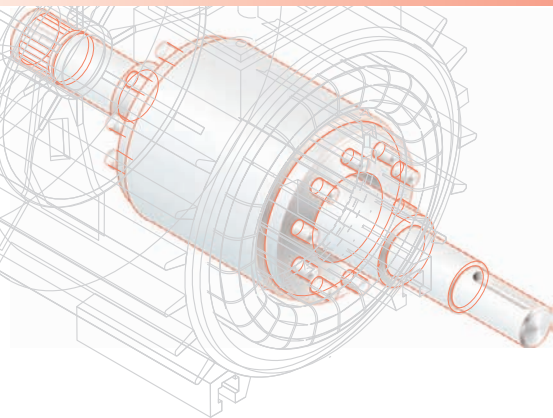

BESEL S.A.

FABRYKA SILNIKÓW ELEKTRYCZNYCH



SILNIKI INDUKCYJNE JEDNOFAZOWE O WZNIOSIE OSI WAŁU 56 serii h

Charakterystyka silników katalogowych:

- silniki ogólnego przeznaczenia do pracy w warunkach klimatu umiarkowanego,
- praca ciągła S1,
- napięcia znamionowe 230V,
- częstotliwość zasilania 50 Hz,
- temperatura otoczenia od -15°C do +40°C,
- kolor malowania RAL 5010.



SINGLE-PHASE INDUCTION MOTORS FRAME SIZE 56 series h

Description of the catalogue motors:

- general purpose motors; temperate climate,
- duty S1,
- rated voltage 230V,
- frequency 50 Hz,
- ambient temperature from -15°C to +40°C,
- standard paint colour RAL 5010.

stopień ochrony: IP54 (IP55; IP56; IP 65; IP 66)
klasa izolacji F (klasa H na życzenie)

degree of protection: IP54 (IP55; IP56; IP 65; IP 66)
insulation class F (class H on request)

Typ	Moc		Prędkość obrotowa [min ⁻¹]	Prąd [A] przy 230 V	Sprawność η [%]	Współczynnik mocy $\cos \varphi_N$	Moment znamionowy M_N [Nm]	Krotność prądu rozruchowego I_r/I_N	Krotność momentu rozruchowego M_r/M_N	$\frac{M_{max}}{M_N}$	Moment bezwładności J [kgm ²]	Kondensator pracy [μ F] 450V	Masa [kg]
	[kW]	[KM]											
Frame size	Rated output		Rated speed [min ⁻¹]	Rated current [A] at 230 V	Efficiency η [%]	Power factor $\cos \varphi_N$	Torque T_N [Nm]	Starting current/ rated current I_L/I_N	Starting torque/ rated torque T_L/T_N	$\frac{T_b}{T_N}$	Moment of inertia J [kgm ²]	Run capacitor [μ F] 450V	Motor weight [kg]
	[kW]	[HP]											

Silniki o normalnym momencie rozruchowym

Motors with standard starting torque

SEh 56-2A	0,09	0,12	2840	0,90	55	0,80	0,30	2,4	0,55	1,9	0,00007	3	2,9
SEh 56-2B	0,12	0,17	2860	1,00	60	0,85	0,40	2,7	0,50	2,0	0,00009	5	3,3
SEh 56-2C	0,18	0,25	2830	1,50	60	0,87	0,61	2,8	0,55	1,7	0,00010	6	3,4
SEh 56-4A	0,06	0,08	1410	0,65	45	0,90	0,41	2,0	0,70	1,7	0,00020	3	2,8
SEh 56-4B	0,09	0,12	1420	0,95	50	0,85	0,61	1,9	0,70	1,7	0,00025	4	3,3
SEh 56-4C	0,12	0,17	1400	1,20	50	0,86	0,81	2,0	0,50	1,5	0,00030	5	3,4

Silniki o podwyższonym momencie rozruchowym

Motors with increased starting torque

SEh 56-2A	0,06	0,08	2800	0,85	45	0,75	0,21	1,8	1,40	2,5	0,00007	3	2,9
SEh 56-2B	0,09	0,12	2790	1,00	50	0,80	0,31	2,2	1,10	2,3	0,00009	5	3,3
SEh 56-2C	0,12	0,17	2800	1,30	52	0,77	0,41	2,7	0,80	2,0	0,00010	5	3,4
SEh 56-4A	0,04	0,06	1390	0,60	35	0,85	0,28	1,5	1,60	2,4	0,00020	3	2,8
SEh 56-4B	0,06	0,08	1390	0,90	35	0,80	0,41	1,5	1,50	2,5	0,00025	4	3,3
SEh 56-4C	0,09	0,12	1340	1,10	45	0,83	0,64	1,8	1,10	1,9	0,00030	5	3,4

Silniki mogą być wykonane i certyfikowane na zgodność z wymogami normy UL 1004 lub CSA C22.2 No 100-04.

Silniki odpowiadają wymaganiom Polskiej Normy PN-EN 60034-1 oraz normom międzynarodowym IEC 60034-1.

Wszystkie silniki posiadają znak CE.

Motors may be certified for safety that they are manufactured according to the requirements of the UL 1004 or CSA C22.2 No 100-04.

Motors meet requirements of Polish Standard PN-EN 60034-1 and the international rules IEC 60034-1.

All motors are provided with CE mark.

Silniki na łapach
Forma wykonania
IMB3

Foot - mounted motors
Type of construction
IMB3

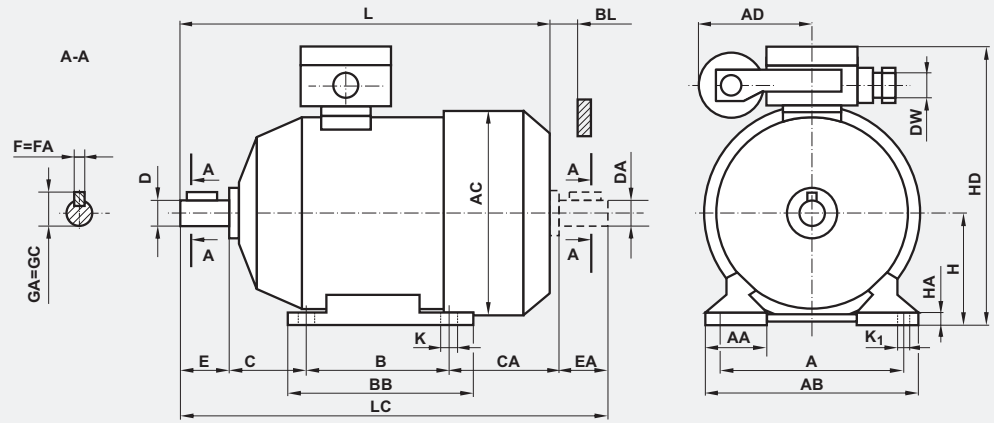

Forma wykonania IMB3

Type of construction IMB3

Typ Frame size	Wymiary (mm)																Dimensions (mm)						Łożyska Bearings
	A	B	C	CA	D=DA	E=EA	F=FA	GA=GC	H	K	K ₁	DW	AA	AB	AC	AD _{max}	BL _{min}	HA	HD	L	LC		
SE(M)h 56-A				66,5																183	208,5	6201 2Z	
SE(M)h 56-B	90	71	36	74,5	9j6	20	3h9	10,2	56-0,5	5,8	8	M20	30	110	117	74	92	11	7	154	193		216,5
SE(M)h 56-C				82,5																	200		225,5

Silniki kołnierzowe
Formy wykonania
IMB5, IMB14

Flange - mounted motors
Types of construction
IMB5, IMB14

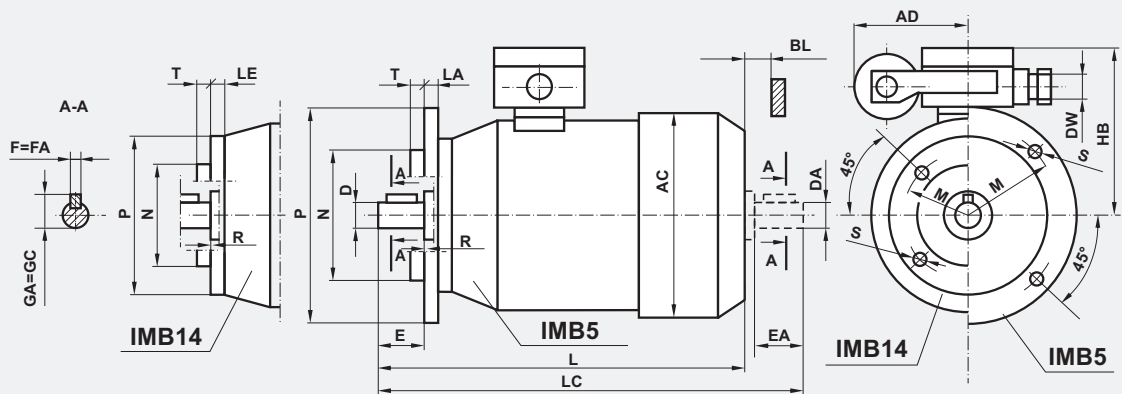

Forma wykonania IMB5

Type of construction IMB5

Typ Frame size	Wymiary (mm)											Dimensions (mm)								Łożyska Bearings
	Kołnierz Flange	P	M	N	S	D=DA	E=EA	F=FA	GA=GC	LA	T	R	DW	AC	AD _{max}	BL _{min}	HB	L	LC	
SE(M)Kh 56-A																		183	208,5	6201 2Z
SE(M)Kh 56-B	B5	120	100	80j6	7	9j6	20	3h9	10,2	8	3	0	M20	117	74	11	98	193	216,5	
SE(M)Kh 56-C																		200	225,5	

Forma wykonania IMB14

Type of construction IMB14

Typ Frame size	Wymiary (mm)											Dimensions (mm)								Łożyska Bearings
	Kołnierz Flange	P	M	N	S	D=DA	E=EA	F=FA	GA=GC	LE	T	R	DW	AC	AD _{max}	BL _{min}	HB	L	LC	
SE(M)Kh 56-A1	B14/1	105	85	70j6	M6	9j6	20	3h9	10,2	15	2,5	0	M20	117	74	11	98	183	208,5	6201 2Z
SE(M)Kh 56-A2	B14/2	80	65	50j6	M5					12,5								193	216,5	
SE(M)Kh 56-B1	B14/1	105	85	70j6	M6					15								200	225,5	
SE(M)Kh 56-B2	B14/2	80	65	50j6	M5					12,5										
SE(M)Kh 56-C1	B14/1	105	85	70j6	M6					15										
SE(M)Kh 56-C2	B14/2	80	65	50j6	M5					12,5										

Producent zastrzega sobie możliwość zmian danych zawartych w karcie katalogowej wynikających z ciągłego doskonalenia wyrobu.

As part of our development program, we reserve the right to alter or amend any of the specifications without giving prior notice.



BESEL S.A.

FABRYKA SILNIKÓW ELEKTRYCZNYCH

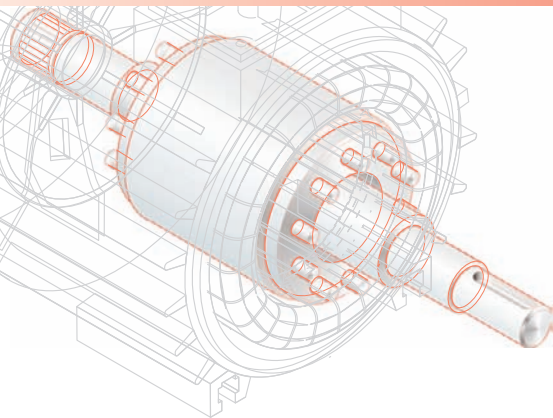

SILNIKI INDUKCYJNE JEDNOFAZOWE O WZNIOSIE OSI WAŁU 63 serii h

Charakterystyka silników katalogowych:

- silniki ogólnego przeznaczenia do pracy w warunkach klimatu umiarkowanego,
- praca ciągła S1,
- napięcia znamionowe 230V,
- częstotliwość zasilania 50 Hz,
- temperatura otoczenia od -15°C do +40°C,
- kolor malowania RAL 5010.



SINGLE-PHASE INDUCTION MOTORS FRAME SIZE 63 series h

Description of the catalogue motors:

- general purpose motors; temperate climate,
- duty S1,
- rated voltage 230V,
- frequency 50 Hz,
- ambient temperature from -15°C to +40°C,
- standard paint colour RAL 5010.

stopień ochrony: IP54 (IP55; IP56; IP 65; IP 66)
klasa izolacji F (klasa H na życzenie)

degree of protection: IP54 (IP55; IP56; IP 65; IP 66)
insulation class F (class H on request)

Typ	Moc		Prędkość obrotowa [min ⁻¹]	Prąd [A] przy 230 V	Sprawność η [%]	Współczynnik mocy $\cos \varphi_N$	Moment znamionowy MN [Nm]	Krotność prądu rozruchowego I_r/I_N	Krotność momentu rozruchowego M_r/M_N	$\frac{M_{max}}{M_N}$	Moment bezwładności J [kgm ²]	Kondensator pracy $[\mu F]$ 450V	Kondensator rozruchowy $[\mu F]$ 450V	Masa [kg]
	[kW]	[KM]												
Frame size	Rated output [kW]	[HP]	Rated speed [min ⁻¹]	Rated current [A] at 230 V	Efficiency η [%]	Power factor $\cos \varphi_N$	Torque T _N [Nm]	Starting current/ rated current I_r/I_N	Starting torque/ rated torque T_L/T_N	$\frac{T_b}{T_N}$	Moment of inertia J [kgm ²]	Run capacitor $[\mu F]$ 450V	Start capacitor $[\mu F]$ 450V	Motor weight [kg]

Silniki o normalnym momencie rozruchowym

Motors with standard starting torque

SEh 63-2A	0,18	0,25	2840	1,40	57	0,98	0,61	2,4	0,75	1,9	0,000175	8	-	3,7
SEh 63-2B	0,25	0,33	2840	1,70	65	0,98	0,84	2,6	0,65	1,9	0,000235	10	-	4,2
SEh 63-2C	0,37	0,50	2840	2,40	71	0,97	1,24	2,8	0,50	1,7	0,000310	12	-	5,0
SEh 63-4A	0,12	0,17	1400	1,20	50	0,86	0,82	1,8	0,55	1,5	0,000240	5	-	4,1
SEh 63-4B	0,18	0,25	1400	1,50	57	0,95	1,23	1,9	0,70	1,4	0,000307	8	-	4,3
SEh 63-4C	0,25	0,33	1360	1,90	62	0,95	1,76	2,0	0,50	1,4	0,000380	10	-	4,9

Silniki o podwyższonym momencie rozruchowym

Motors with increased starting torque

SEMh 63-2A	0,12	0,17	2800	1,10	52	0,88	0,41	2,1	1,20	2,4	0,000175	6	-	3,7
SEMh 63-2B	0,18	0,25	2780	1,50	57	0,92	0,62	2,4	1,00	2,0	0,000235	8	-	4,2
SEMh 63-2C	0,25	0,33	2760	1,90	64	0,92	0,87	2,2	0,90	2,0	0,000310	10	-	4,8
SEMh 63-4A	0,09	0,12	1350	1,10	44	0,83	0,63	1,7	1,10	1,8	0,000240	5	-	4,1
SEMh 63-4B	0,12	0,17	1360	1,25	53	0,88	0,84	1,8	1,20	1,9	0,000307	6	-	4,3
SEMh 63-4C	0,18	0,25	1320	1,80	52	0,90	1,30	1,6	1,10	1,7	0,000380	8	-	4,9

Silniki o dużym momencie rozruchowym

Motors with high starting torque

SEh 63-2AF	0,18	0,25	2840	1,40	57	0,98	0,61	4,2	1,9	1,9	0,000175	8	25	3,9
SEh 63-2BF	0,25	0,33	2840	1,70	65	0,98	0,84	4,2	2,1	1,9	0,000235	10	30	4,4
SEh 63-2CF	0,37	0,50	2840	2,40	71	0,97	1,24	4,7	1,8	1,7	0,000310	12	40	5,3
SEh 63-4AF	0,12	0,17	1400	1,20	50	0,86	0,82	3,6	1,8	1,5	0,000240	5	14	4,3
SEh 63-4BF	0,18	0,25	1400	1,50	57	0,95	1,23	3,5	1,6	1,4	0,000307	8	16	4,5
SEh 63-4CF	0,25	0,33	1360	1,90	62	0,95	1,76	3,3	1,6	1,4	0,000380	10	20	5,2

Silniki SEh 63-...F są wyposażone w dwa kondensatory - pracy i rozruchowy oraz wyłącznik odśrodkowy.

SEh 63-...F motors are equipped with two capacitors - run, start and centrifugal switch.

Silniki mogą być wykonane i certyfikowane na zgodność z wymogami normy UL 1004 lub CSA C22.2 No 100-04.

Motors may be certified for safety that they are manufactured according to the requirements of the UL 1004 or CSA C22.2 No 100-04.

Silniki odpowiadają wymaganiom Polskiej Normy PN-EN 60034-1 oraz normom międzynarodowym IEC 60034-1.

Motors meet requirements of Polish Standard PN-EN 60034-1 and the international rules IEC 60034-1.

Wszystkie silniki posiadają znak CE.

All motors are provided with CE mark.



BESEL S.A.

FABRYKA SILNIKÓW ELEKTRYCZNYCH

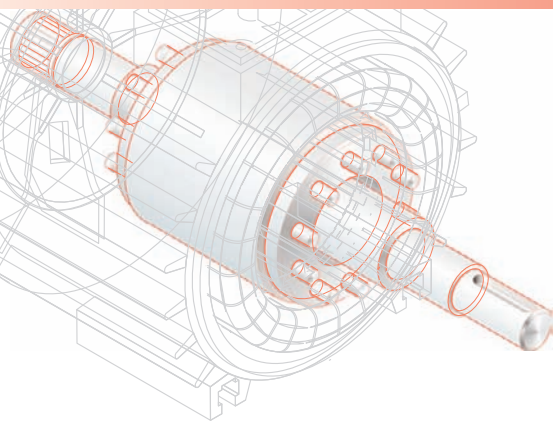

SILNIKI INDUKCYJNE JEDNOFAZOWE O WZNIOSIE OSI WAŁU 71

Charakterystyka silników katalogowych:

- silniki ogólnego przeznaczenia do pracy w warunkach klimatu umiarkowanego,
- praca ciągła S1,
- napięcia znamionowe 230V,
- częstotliwość zasilania 50 Hz,
- temperatura otoczenia od -15°C do +40°C,
- kolor malowania RAL 5010.



SINGLE-PHASE INDUCTION MOTORS FRAME SIZE 71

Description of the catalogue motors:

- general purpose motors; temperate climate,
- duty S1,
- rated voltage 230V,
- frequency 50 Hz,
- ambient temperature from -15°C to +40°C,
- standard paint colour RAL 5010.

stopień ochrony: IP54 (IP55; IP56; IP 65; IP 66)
klasa izolacji F (klasa H na życzenie)

degree of protection: IP54 (IP55; IP56; IP 65; IP 66)
insulation class F (class H on request)

Typ	Moc		Prędkość obrotowa [min ⁻¹]	Prąd [A] przy 230 V	Sprawność η [%]	Współczynnik mocy cos φ _N	Moment znamionowy M _N [Nm]	Krotność prądu rozruchowego I _r /I _N	Krotność momentu rozruchowego M _r /M _N	$\frac{M_{max}}{M_N}$	Moment bezwładności J [kgm ²]	Kondensator pracy [μF] 450V	Kondensator rozruchowy [μF] 450V	Masa [kg]
	[kW]	[KM]												
Frame size	Rated output [kW]	[HP]	Rated speed [min ⁻¹]	Rated current [A] at 230 V	Efficiency η [%]	Power factor cos φ _N	Torque T _N [Nm]	Starting current/ rated current I _r /I _N	Starting torque/ rated torque T _L /T _N	$\frac{T_b}{T_N}$	Moment of inertia J [kgm ²]	Run capacitor [μF] 450V	Start capacitor [μF] 450V	Motor weight [kg]

Silniki o normalnym momencie rozruchowym

Motors with standard starting torque

SEh 71-2B	0,55	0,75	2820	3,6	70	0,96	1,86	3,0	0,36	1,6	0,00053	14	-	6,3
SEh 71-2C	0,75	1,00	2820	4,9	71	0,98	2,54	3,0	0,40	1,5	0,00069	25	-	7,7
SEh 71-4A	0,25	0,33	1350	2,4	50	0,92	1,77	2,0	0,35	1,4	0,00061	8	-	5,3
SEh 71-4B	0,37	0,50	1370	2,9	64	0,88	2,60	2,1	0,50	1,4	0,00085	10	-	6,3
SEh 71-4C	0,55	0,75	1350	4,2	65	0,92	3,89	2,2	0,40	1,4	0,00101	18	-	7,3

Silniki o podwyższonym momencie rozruchowym

Motors with increased starting torque

SEMh 71-2A	0,25	0,33	2720	2,0	57	0,97	0,88	2,3	0,80	1,70	0,00039	10	-	5,2
SEMh 71-2B	0,37	0,50	2800	3,0	64	0,84	1,26	2,7	0,70	1,80	0,00054	12	-	6,4
SEMh 71-2C	0,55	0,75	2780	3,6	70	0,95	1,89	3,2	0,65	1,60	0,00069	20	-	7,4
SEMh 71-4B	0,25	0,33	1340	2,5	56	0,80	1,78	2,0	1,00	1,70	0,00085	10	-	6,3
SEMh 71-4C	0,37	0,50	1320	3,2	59	0,88	2,68	2,1	0,80	1,60	0,00101	16	-	7,4

Silniki o dużym momencie rozruchowym

Motors with high starting torque

SEh 71-2BF	0,55	0,75	2820	3,6	70	0,96	1,86	3,6	1,7	1,6	0,00053	14	25	6,5
SEh 71-2CF	0,75	1,00	2820	4,9	71	0,98	2,54	4,0	1,7	1,5	0,00069	25	70	7,8
SEh 71-4BF	0,37	0,50	1370	2,9	64	0,88	2,60	3,5	1,8	1,4	0,00085	10	25	6,5
SEh 71-4CF	0,55	0,75	1350	4,1	65	0,90	3,86	3,6	1,9	1,4	0,00101	18	60	8,0

Silniki SEh 71-...F są wyposażone w dwa kondensatory - pracy i rozruchowy oraz wyłącznik odśrodkowy.

SEh 71-...F motors are equipped with two capacitors - run, start and centrifugal switch.

Silniki mogą być wykonane i certyfikowane na zgodność z wymogami normy UL 1004 lub CSA C22.2 No 100-04.

Motors may be certified for safety that they are manufactured according to the requirements of the UL 1004 or CSA C22.2 No 100-04.

Silniki odpowiadają wymaganiom Polskiej Normy PN-EN 60034-1 oraz normom międzynarodowym IEC 60034-1.

Motors meet requirements of Polish Standard PN-EN 60034-1 and the international rules IEC 60034-1.

Wszystkie silniki posiadają znak CE.

All motors are provided with CE mark.

Silniki na łapach
Forma wykonania
IMB3

Foot - mounted motors
Type of construction
IMB3

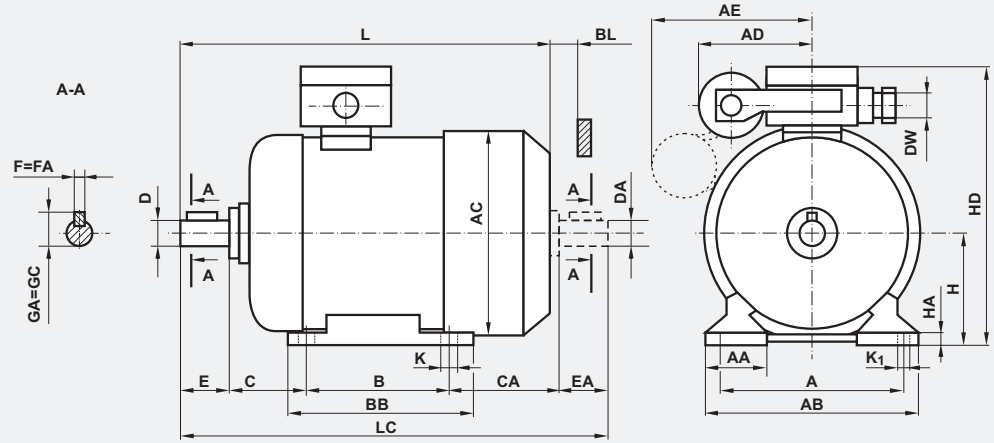

Forma wykonania IMB3

Type of construction IMB3

Typ	Wymiary (mm)																Dimensions (mm)						Łożyska Bearings	
	A	B	C	CA	D=DA	E=EA	F=FA	GA=GC	H	K	K ₁	DW	AA	AB	AC	AD	AE	BB	BL _{min}	HA	HD	L		LC
SE(M)h 71-A	112	90	45	65	14j6	30	5h9	16	71 _{0,5}	7	10	M20	45	142	141	90	-	116	12	8	182	223	261	6203 2Z
SE(M)h 71-B				-													245					283		
SEh 71-BF				88													285					-		
SE(M)h 71-C				106													263					301		
SEh 71-CF				100													303					-		

Silniki kołnierowe
Formy wykonania
IMB5, IMB14

Flange - mounted motors
Types of construction
IMB5, IMB14

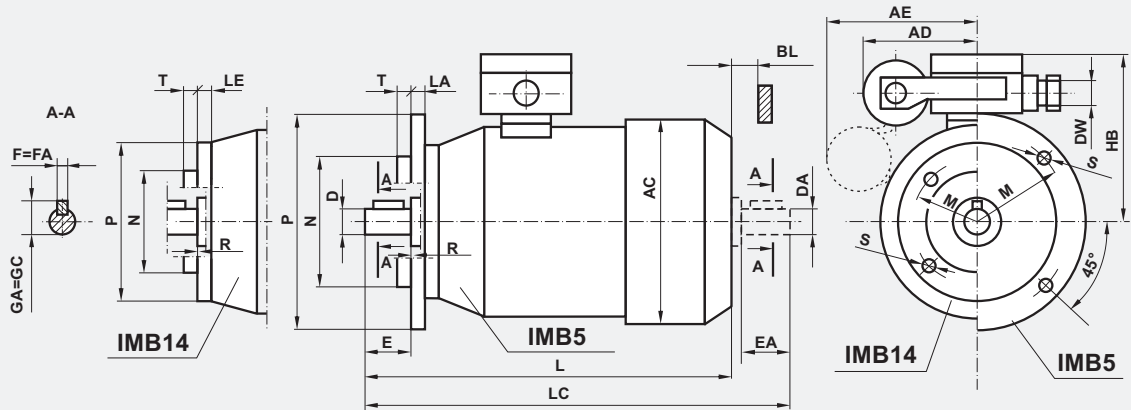

Forma wykonania IMB5

Type of construction IMB5

Typ	Wymiary (mm)											Dimensions (mm)								Łożyska Bearings	
	Kołnierz Flange	P	M	N	S	D=DA	E=EA	F=FA	GA=GC	LA	T	R	DW	AC	AD	AE	BL _{min}	HB	L		LC
SE(M)Kh 71-A	B5	160	130	110j6	10	14j6	30	5h9	16	9	3,5	0	M20	141	90	-	12	111	223	261	6203 2Z
SE(M)Kh 71-B																-			245	283	
SEKh 71-BF																100			285	-	
SE(M)Kh 71-C																-			263	301	
SEKh 71-CF																100			303	-	

Forma wykonania IMB14

Type of construction IMB14

Typ	Wymiary (mm)											Dimensions (mm)								Łożyska Bearings							
	Kołnierz Flange	P	M	N	S	D=DA	E=EA	F=FA	GA=GC	LE	T	R	DW	AC	AD	AE	BL _{min}	HB	L		LC						
SE(M)Kh 71-A1	B14/1	140	115	95j6	M8	14j6	30	5h9	16	14	3,0	0	M20	141	90	-	12	111	223	261	6203 2Z						
SE(M)Kh 71-A2	B14/2	105	85	70j6	M6					12	2,5					-			245	283							
SE(M)Kh 71-B1	B14/1	140	115	95j6	M8					14	3,0					-			285	-							
SEKh 71-BF1	-	-	-	-	-					100	-					-			245	283							
SE(M)Kh 71-B2	B14/2	105	85	70j6	M6					12	2,5					0			M20	141		90	-	12	111	245	283
SEKh 71-BF2	-	-	-	-	-					100	-					-			285	-							
SE(M)Kh 71-C1	B14/1	140	115	95j6	M8					14	3,0					-			263	301							
SEKh 71-CF1	-	-	-	-	-					100	-					-			303	-							
SE(M)Kh 71-C2	B14/2	105	85	70j6	M6					12	2,5					-			263	301							
SEKh 71-CF2	-	-	-	-	-	100	-	-	303	-																	

Producent zastrzega sobie możliwość zmian danych zawartych w karcie katalogowej wynikających z ciągłego doskonalenia wyrobu.

As part of our development program, we reserve the right to alter or amend any of the specifications without giving prior notice.



BESEL S.A.

FABRYKA SILNIKÓW ELEKTRYCZNYCH

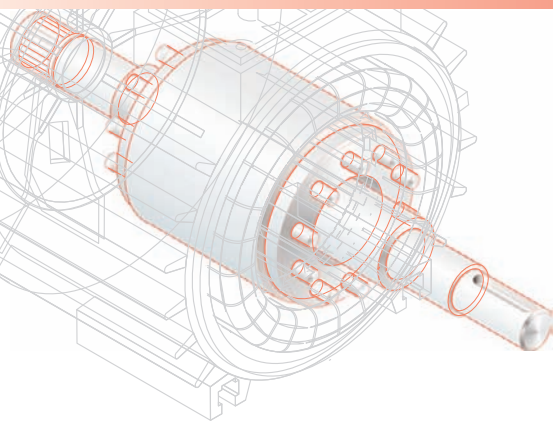

SILNIKI INDUKCYJNE JEDNOFAZOWE O WZNIOSIE OSI WAŁU 80

Charakterystyka silników katalogowych:

- silniki ogólnego przeznaczenia do pracy w warunkach klimatu umiarkowanego,
- praca ciągła S1,
- napięcia znamionowe 230V,
- częstotliwość zasilania 50 Hz,
- temperatura otoczenia od -15°C do +40°C,
- kolor malowania RAL 5010.



SINGLE-PHASE INDUCTION MOTORS FRAME SIZE 80

Description of the catalogue motors:

- general purpose motors; temperate climate,
- duty S1,
- rated voltage 230V,
- frequency 50 Hz,
- ambient temperature from -15°C to +40°C,
- standard paint colour RAL 5010.

stopień ochrony: IP54 (IP55; IP56; IP 65; IP 66)
klasa izolacji F (klasa H na życzenie)

degree of protection: IP54 (IP55; IP56; IP 65; IP 66)
insulation class F (class H on request)

Typ	Moc		Prędkość obrotowa [min ⁻¹]	Prąd [A] przy 230 V	Sprawność η [%]	Współczynnik mocy $\cos \varphi_N$	Moment znamionowy MN [Nm]	Krotność prądu rozruchowego I_r/I_N	Krotność momentu rozruchowego M_r/M_N	$\frac{M_{max}}{M_N}$	Moment bezwładności J [kgm ²]	Kondensator pracy [μ F] 450V	Kondensator rozruchowy [μ F] 450V	Masa [kg]
	[kW]	[KM]												
Frame size	Rated output [kW]	[HP]	Rated speed [min ⁻¹]	Rated current [A] at 230 V	Efficiency η [%]	Power factor $\cos \varphi_N$	Torque T _N [Nm]	Starting current/ rated current I_r/I_N	Starting torque/ rated torque T_r/T_N	$\frac{T_b}{T_N}$	Moment of inertia J [kgm ²]	Run capacitor [μ F] 450V	Start capacitor [μ F] 450V	Motor weight [kg]

Silniki o normalnym momencie rozruchowym

Motors with standard starting torque

SEh 80-2B	1,10	1,50	2780	7,0	72	0,97	3,78	2,7	0,40	1,4	0,00111	25	-	9,8
SEh 80-2C	1,50	2,00	2740	9,1	73	0,99	5,23	2,7	0,50	1,5	0,00142	40	-	11,8
SEh 80-2D	2,00	2,80	2780	13	74	0,99	6,87	2,5	0,40	1,4	0,00210	50	-	15,2
SEh 80-4A	0,55	0,75	1380	3,9	68	0,90	3,81	2,6	0,45	1,4	0,00157	16	-	9,6
SEh 80-4B	0,75	1,00	1370	4,9	73	0,92	5,23	2,5	0,40	1,3	0,00208	20	-	9,9
SEh 80-4C	1,10	1,50	1370	7,2	72	0,93	7,67	2,6	0,40	1,4	0,00265	30	-	11,4

Silniki o podwyższonym momencie rozruchowym

Motors with increased starting torque

SEmH 80-2A	0,55	0,75	2780	4,1	67	0,84	1,89	3,0	0,70	1,8	0,00080	20	-	8,0
SEmH 80-2B	0,75	1,00	2800	5,0	70	0,94	2,56	3,4	0,65	1,9	0,00111	25	-	9,7
SEmH 80-2C	1,10	1,50	2780	6,4	76	0,98	3,75	3,5	0,55	1,8	0,00142	30	-	11,7
SEmH 80-2D	1,50	2,00	2700	10,2	71	0,90	5,31	2,8	0,70	1,6	0,00210	40	-	13,7
SEmH 80-4A	0,37	0,50	1350	3,0	64	0,85	2,62	2,3	0,90	1,8	0,00156	14	-	8,3
SEmH 80-4B	0,55	0,75	1360	3,9	68	0,91	3,86	2,6	0,60	1,6	0,00208	20	-	9,5
SEmH 80-4C	0,75	1,00	1340	5,6	65	0,90	5,35	2,5	0,65	1,5	0,00265	25	-	11,5

Silniki o dużym momencie rozruchowym

Motors with high starting torque

SEh 80-2BF	1,10	1,50	2780	7,0	72	0,97	3,78	3,5	1,7	1,4	0,00111	25	70	10,6
SEh 80-2CF	1,50	2,00	2800	9,5	75	0,96	5,12	3,7	1,9	1,7	0,00142	40	60	12,2
SEh 80-4BF	0,75	1,00	1370	4,9	73	0,92	5,23	3,0	1,8	1,4	0,00208	20	60	10,4
SEh 80-4CF	1,10	1,50	1400	7,4	74	0,91	7,50	3,6	1,9	1,5	0,00265	30	75	12,2

Silniki SEh 80-...F są wyposażone w dwa kondensatory - pracy i rozruchowy oraz wyłącznik odśrodkowy.

SEh 80-...F motors are equipped with two capacitors - run, start and centrifugal switch.

Silniki mogą być wykonane i certyfikowane na zgodność z wymogami normy UL 1004 lub CSA C22.2 No 100-04.

Motors may be certified for safety that they are manufactured according to the requirements of the UL 1004 or CSA C22.2 No 100-04.

Silniki odpowiadają wymaganiom Polskiej Normy PN-EN 60034-1 oraz normom międzynarodowym IEC 60034-1.

Motors meet requirements of Polish Standard PN-EN 60034-1 and the international rules IEC 60034-1.

Wszystkie silniki posiadają znak CE.

All motors are provided with CE mark.



BESEL S.A.

FABRYKA SILNIKÓW ELEKTRYCZNYCH

SILNIKI INDUKCYJNE JEDNOFAZOWE O WZNIOSIE OSI WAŁU 90

Charakterystyka silników katalogowych:

- silniki ogólnego przeznaczenia do pracy w warunkach klimatu umiarkowanego,
- praca ciągła S1,
- napięcia znamionowe 230V,
- częstotliwość zasilania 50 Hz,
- temperatura otoczenia od -15°C do +40°C,
- kolor malowania RAL 5010.

SINGLE-PHASE INDUCTION MOTORS FRAME SIZE 90

Description of the catalogue motors:

- general purpose motors; temperate climate,
- duty S1,
- rated voltage 230V,
- frequency 50 Hz,
- ambient temperature from -15°C to +40°C,
- standard paint colour RAL 5010.



stopień ochrony: IP54 (IP55; IP56; IP 65; IP 66)
klasa izolacji F (klasa H na życzenie)

degree of protection: IP54 (IP55; IP56; IP 65; IP 66)
insulation class F (class H on request)

Typ	Moc		Prędkość obrotowa [min ⁻¹]	Prąd [A] przy 230 V	Sprawność η [%]	Współczynnik mocy cos φ _N	Moment znamionowy M _N [Nm]	Krotność prądu rozruchowego I _r /I _N	Krotność momentu rozruchowego M _r /M _N	$\frac{M_{max}}{M_N}$	Moment bezwładności J [kgm ²]	Kondensator pracy [μF] 450V	Kondensator rozruchowy [μF] 450V	Masa [kg]
	[kW]	[KM]												
Frame size	Rated output [kW]	[HP]	Rated speed [min ⁻¹]	Rated current [A] at 230 V	Efficiency η [%]	Power factor cos φ _N	Torque T _N [Nm]	Starting current/ rated current I _r /I _N	Starting torque/ rated torque T _L /T _N	$\frac{T_b}{T_N}$	Moment of inertia J [kgm ²]	Run capacitor [μF] 450V	Start capacitor [μF] 450V	Motor weight [kg]

Silniki o normalnym momencie rozruchowym

Motors with standard starting torque

SEh 90-2S	1,50	2,00	2740	9,1	73	0,99	5,12	2,7	0,50	1,5	0,0012	40	-	11,8
SEh 90-2L	2,00	2,80	2780	13,0	74	0,99	6,87	2,5	0,40	1,4	0,0016	50	-	15,2
SEh 90-4S	1,10	1,50	1370	7,2	72	0,93	7,70	2,6	0,40	1,4	0,0024	30	-	11,4
SEh 90-4L	1,30	1,80	1370	9,0	72	0,90	9,10	2,8	0,38	1,4	0,0032	40	-	14,0

Silniki o podwyższonym momencie rozruchowym

Motors with increased starting torque

SEMh 90-2S	1,10	1,50	2780	6,4	76	0,98	3,81	3,5	0,55	1,8	0,0012	30	-	11,7
SEMh 90-2L	1,50	2,00	2700	10,2	71	0,90	5,31	2,8	0,70	1,6	0,0016	40	-	15,7
SEMh 90-4S	0,75	1,00	1340	5,6	65	0,90	5,19	2,5	0,65	1,5	0,0024	25	-	12,5
SEMh 90-4L	1,10	1,50	1300	7,8	67	0,92	8,08	2,2	0,50	1,4	0,0032	40	-	14,5

Silniki o dużym momencie rozruchowym

Motors with high starting torque

SEh 90-2SF	1,50	2,00	2740	9,1	73	0,99	5,12	3,6	1,7	1,6	0,0012	40	60	13,5
SEh 90-2LF	2,00	2,80	2780	13,0	74	0,99	6,87	3,5	1,6	1,4	0,0016	50	75	16,3
SEh 90-4SF	1,10	1,50	1400	7,5	73	0,90	7,50	4,0	1,6	1,5	0,0024	30	75	13,7
SEh 90-4LF	1,30	1,80	1360	9,0	72	0,90	9,13	3,2	1,8	1,4	0,0032	40	90	14,8

Silniki SEh 90-...F są wyposażone w dwa kondensatory - pracy i rozruchowy oraz wyłącznik odśrodkowy.

SEh 90-...F motors are equipped with two capacitors - run, start and centrifugal switch.

Silniki mogą być wykonane i certyfikowane na zgodność z wymogami normy UL 1004 lub CSA C22.2 No 100-04.

Motors may be certified for safety that they are manufactured according to the requirements of the UL 1004 or CSA C22.2 No 100-04.

Silniki odpowiadają wymaganiom Polskiej Normy PN-EN 60034-1 oraz normom międzynarodowym IEC 60034-1.

Motors meet requirements of Polish Standard PN-EN 60034-1 and the international rules IEC 60034-1.

Wszystkie silniki posiadają znak CE.

All motors are provided with CE mark.

**Silniki na łapach
Forma wykonania
IMB3**

**Foot - mounted motors
Type of construction
IMB3**

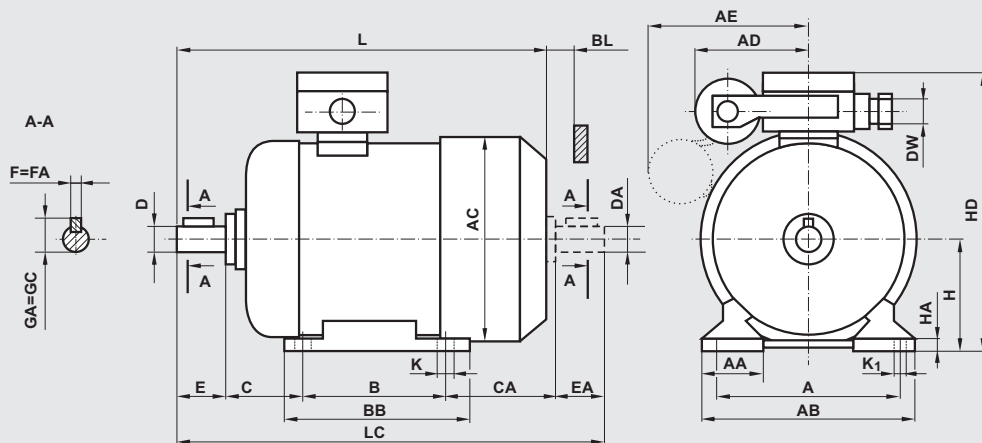

Forma wykonania IMB3

Type of construction IMB3

Typ	Wymiary (mm)																Dimensions (mm)					Łożyska			
	Frame size	A	B	C	CA	D=DA	E=EA	F=FA	GA=GC	H	K	K ₁	DW	AA	AB	AC	AD	AE	BB	BL min	HA	HD	L	LC	P
SE(M)h 90-S	140	100	56	114	24j6	50	8h9	27	90 _{-0,5}	10	13	M20	60	170	157	95	-	153	15	12	208	316	376	6204 2Z	6205 2Z
SEh 90-SF																	120					350	-		
SE(M)h 90-L		-	328	388																					
SEh 90-LF		120	364	-																					

**Silniki kołnierkowe
Formy wykonania
IMB5, IMB14**

**Flange - mounted motors
Types of construction
IMB5, IMB14**

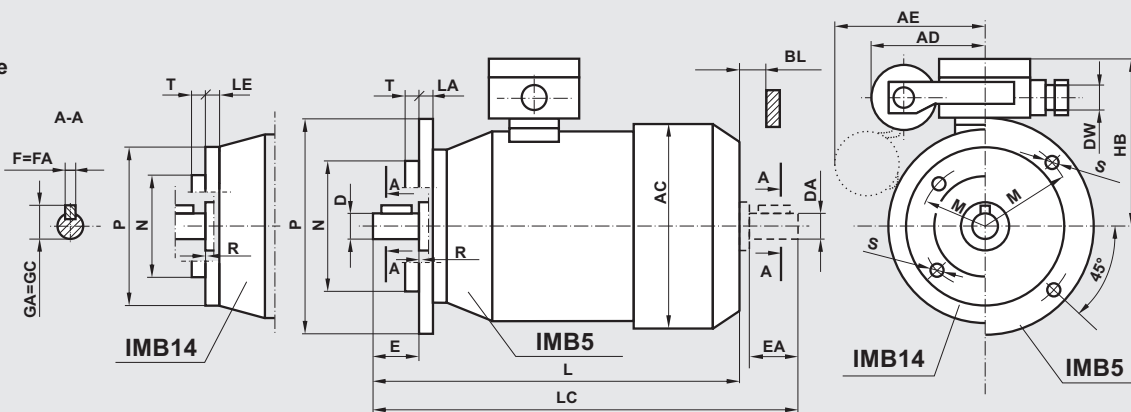

Forma wykonania IMB5

Type of construction IMB5

Typ	Wymiary (mm)											Dimensions (mm)										Łożyska		
	Frame size	Kołnierz Flange	P	M	N	S	D=DA	E=EA	F=FA	GA=GC	LA	T	R	DW	AC	AD	AE	BL min	HB	L	LC	P	N	
SE(M)Kh 90-S	B5	200	165	130j6	12	24j6	50	8h9	27	10	3,5	0	M20	157	95	-	15	118	316	376	6204 2Z	6205 2Z		
SEKh 90-SF																120							350	-
SE(M)Kh 90-L																-							328	388
SEKh 90-LF																120							364	-

Forma wykonania IMB14

Type of construction IMB14

Typ	Wymiary (mm)											Dimensions (mm)										Łożyska															
	Frame size	Kołnierz Flange	P	M	N	S	D=DA	E=EA	F=FA	GA=GC	LE	T	R	DW	AC	AD	AE	BL min	HB	L	LC	P	N														
SE(M)Kh 90-S1	B14/1	160	130	110j6	M8	24j6	50	8h9	27	10	3,5	0	M20	157	95	-	15	118	316	376	6204 2Z	6205 2Z															
SEKh 90-SF1																120							350	-													
SE(M)Kh 90-S2	B14/2	140	115	95j6	M8						3,0					-							-	-	-	-	-	-	-	-	-	-	-	-	-	-	-
SEKh 90-SF2																																					
SE(M)Kh 90-L1	B14/1	160	130	110j6	M8						3,5					-							-	-	-	-	-	-	-	-	-	-	-	-	-	-	-
SEKh 90-LF1																																					
SE(M)Kg 90-L2	B14/2	140	115	95j6	M8	3,0	-	-	-	-	-	-	-	-	-	-	-	-	-	-	-	-															
SEKh 90-LF2																							120	328	388												

Producent zastrzega sobie możliwość zmian danych zawartych w karcie katalogowej wynikających z ciągłego doskonalenia wyrobu.

As part of our development program, we reserve the right to alter or amend any of the specifications without giving prior notice.