

Joystick Controllers

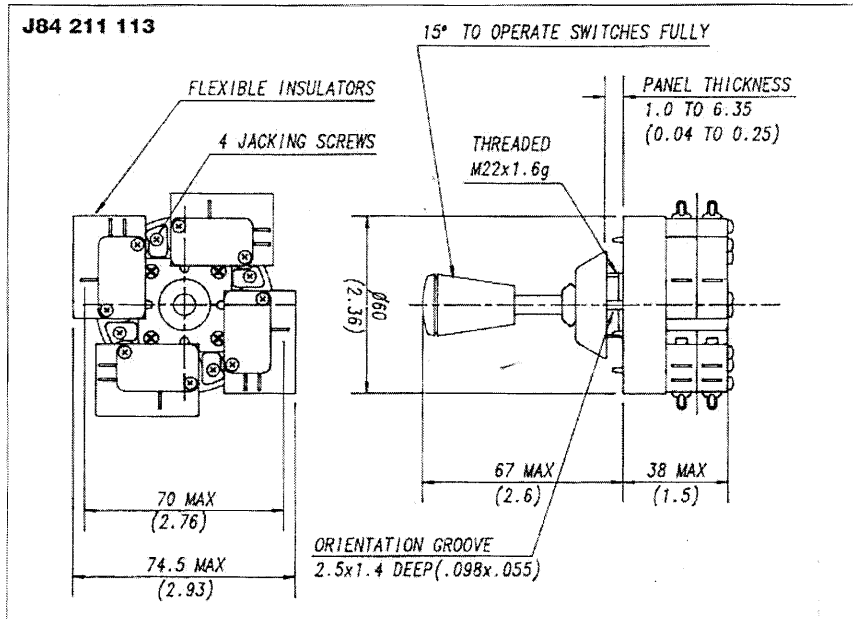
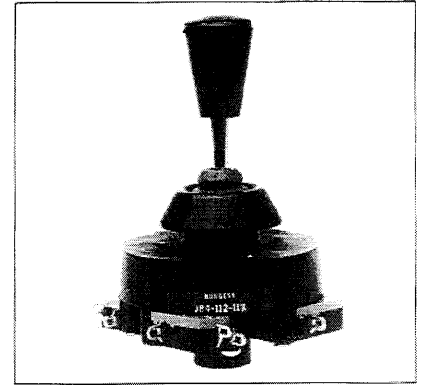

Multi-directional switching assemblies containing Burgess/SAIA miniature or sub-miniature micro switches. They offer positive, convenient, space saving control for many applications.

Facilities include momentary, latching and stirring action. A lift to operate feature is also available to prevent accidental operation.

Typical uses include:- machine tools, presses, fork lift trucks, cranes, earth moving equipment, pedestrian controlled vehicles, railway signalling, baggage handling equipment, stair lifts etc.

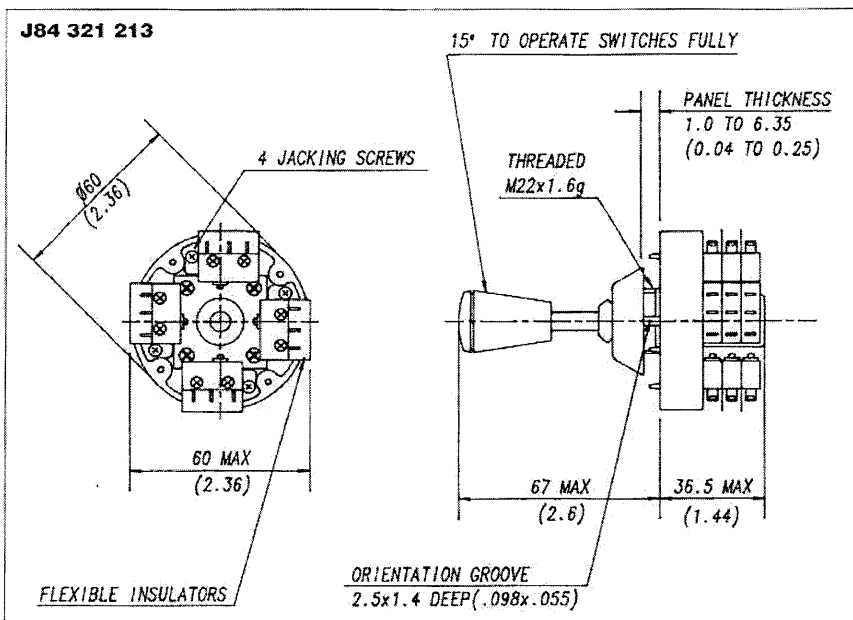

JOYSTICK CONTROLLERS

Specifications

Top plate:

Glass fibre reinforced polyamide (PA.6.6)

Control rod:

Steel chrome plated

Bezel/knob:

Phenolic

Cowl/'O' ring:

Silicone rubber

Temperature range:

-40°C to +85°C

Mechanical life:

5 x 10⁵ cycles minimum

Type of protection:

Cowl and 'O' ring provide front of panel sealing. For details of insert switch protection refer to the appropriate sections

Mounting:

Via single hole 22.5mm (0.89in) dia

Insert switches:

V4NT7 – Sub-miniature

XG03 – Miniature

(Other types may be possible please consult SAIA-Burgess Electronics)

Circuit diagram

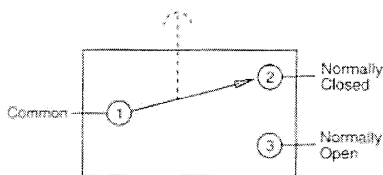

Functions and Facilities

Gates:

Available with stirring action, 2 or 4 gates.

Action:

Available with momentary or latching action. Stirring action versions are provided with switches spaced at 90° and can operate adjacent switches simultaneously.

Operation:

Available as 'normal' or 'lift-to-operate'. The 'lift-to-operate' feature provides a safeguard against accidental operation where the control rod must be lifted by a minimum of 1.5mm (0.06in) before it can be moved from the central 'off' position.

Mounting recommendations:

The complete assembly less bezel should be inserted into the hole in the panel, the bezel should be screwed on to the threaded sleeve until it is finger tight and the unit locked in position by screwing in the four jacking screws.

V4NT7

Recommended Max. Electrical Ratings		
Voltage	Resistive load	Inductive load
AC	A	A
up to 250	5	5

XG03

Recommended Max. Electrical Ratings		
Voltage	Resistive load	Inductive load
AC	A	A
up to 250	16	12

Recommended Max. Electrical Ratings		
Voltage	Resistive load	Inductive load
DC	A	A
up to 30	5	3
50	1	1
75	0.75	0.75

Recommended Max. Electrical Ratings		
Voltage	Resistive load	Inductive load
DC	A	A
up to 30	16	16
50	3	1.5
75	1	0.6
125	0.5	0.3
250	0.3	0.2

Standard Joysticks Available

JOYSTICK CONTROLLERS

Range	Number of Gates	Switches per Gate	Type of Operations	V4NT7 Switch		XG03 Switch	
				Momentary Action	Latch-in Action	Momentary Action	Latch-in Action
J80	0 stirring action	4 switches at 90° pitch	Normal	J80 141 213		J80 141 113	
			Normal Lift	J82 111 213	J82 121 213	J82 111 113	J82 121 113
J82	2	2	Normal			J82 211 113	
			Lift	J82 212 213			
		3	Normal				
			Lift		J82 322 213		
1	Normal	J84 111 213		J84 111 113	J84 121 113		
	Lift			J84 112 113			
J84	4	2	Normal	J84 211 213		J84 211 113	
			Lift			J84 212 113	
		3	Normal		J84 321 213		
			Lift		J84 322 213		

For other versions, please contact SAIA-Burgess Electronics.

JOYSTICK CONTROLLERS

Ordering References

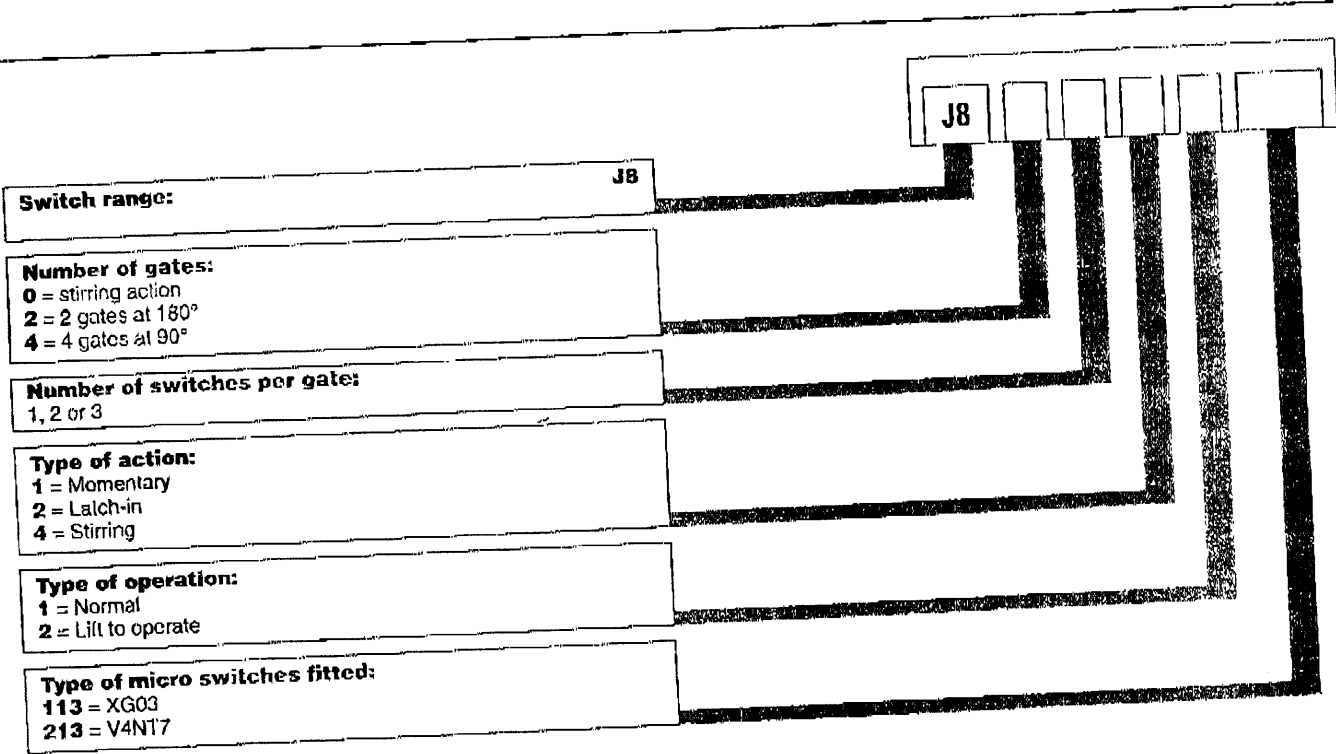

Specifications

Housing:

TPS1 }
TPS2 } Flame retardant polycarbonate
DS3 }
DS1 } Backing plate mild steel zinc plate
DS6 }

Plunger:

TPS1 }
TPS2 } ABS polymer
DS1 }
DS3 } Stainless steel
DS6 }

Mechanism:

TPS1 }
TPS2 } Single pole changeover
DS1 }
DS3 } Single pole changeover
DS6 } Double pole changeover

Contacts:

Fine silver

Terminals:

TPS1 }
TPS2 } Screws with clamps
DS1 }
DS3 } Solder tags
DS6 }

Temperature range:

-10°C to +85°C

Mechanical life:

TPS1 }
TPS2 } 10⁷ cycles minimum
DS1 }
DS3 } 10⁶ cycles minimum
DS6 } (Impact free actuation)

Type of protection:

IP40 (Insert switch)

Approvals:

TPS1 }
TPS2 } UL
DS1 }
DS3 } CSA UL
DS6 }

TPS1/TPS2

Recommended Max. Electrical Ratings		
Voltage	Resistive load	Inductive load
AC	A	A
up to		
250	15	5
380	10	5

Recommended Max. Electrical Ratings		
Voltage	Resistive load	Inductive load
DC	A	A
up to		
15	15	10
30	5	5
50	1	0.5
75	0.75	0.3

DS1/DS3/DS6

Recommended Max. Electrical Ratings		
Voltage	Resistive load	Inductive load
AC	A	A
up to		
250	10	10

Recommended Max. Electrical Ratings		
Voltage	Resistive load	Inductive load
DC	A	A
up to		
30	10	10
50	3	2.5
75	1	0.5

Circuit diagram TPS1

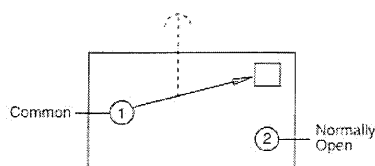

Circuit diagram DS1/DS3

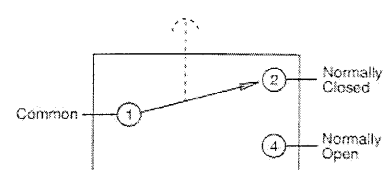

Circuit diagram TPS2

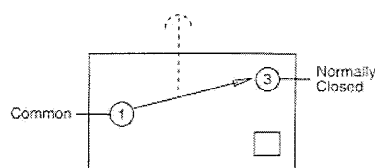

Circuit diagram DS6

