

Control and Automation

For industrial applications ED.02

Electronic relays



GE imagination at work



Everything is

Order codes

- F.3 Series NMV
Multivoltage electronic timers. 22.5mm module
- F.4 Series D
Single voltage electronic timers. 45mm module
- F.4 Liquid level detectors relay
- F.4 Earth leakage relays
- F.5 Protection relays
- F.6 Detection relays
- F.6 Control and protection relays

Technical data

- F.7 Series NMV
- F.11 Series D

Dimensions

- F.20 Series NMV and D

Plug-in relays and Auxiliary contactors

Motor protection devices

Contactors and Thermal overload relays

Motorstarters

Control and signalling units

Electronic relays

Limit switches

Speed drive units

Main switches

Numerical index

A

B

C

D

E

F

G

H

I

X

under control





Series NMV Multivoltage
22.5mm module

Series D Single voltage
45mm module





Standards

VDE 0106	CSA C 22.2 Nr.14	UNE 20-119
VDE 0110	UL 94	IEC/EN 60947-5-1
EN 50002	UL 508	IEC/EN 61812-1
EN 50042	IEC 255.5	CE
		CUL

Range overview

	22.5mm module		45mm module	
	Series NMV Multivoltage		Series D Single voltage	
Delay		Pg.		Pg.
Delayed ON	NMTCV	F.3		
OFF delay	NMRDV	F.3		
			NMMFV	F.5
Star-delta starter	NMETV	F.3		
Multifunction	NMMFV	F.3		
Impulse			NMMFV	F.5
Delayed ON			NMMFV	F.5
ON delay with auxiliary contact	NMMFV	F.3		
OFF delay with auxiliary contact	NMMFV	F.3		
ON + OFF with auxiliary contact	NMMFV	F.3		
Intermittence				
Symmetric intermittence				
Asymmetric intermittence	NMIVV	F.3		
Control				
Motor re-start control relay				RCRT6 F.4
Detectors				
Liquid level detector relay				DINIL F.4
Voltage detector relay				RDT F.6
Current detector relay with delay				RDIT F.6
Relay				
Differential earth leakage				RDHT/A F.4
Thermistor relay				RS01N F.6
Frequency control relay				RCF F.6
Protection (three-phase lines)				
Integral protection relay for 3-Phase lines				RDF1 F.5
Phase sequence				RSF F.5
Phase sequence and phase failure				RSFF F.5
Maximum and minimum voltage				RTMM F.5
Protection (single-phase lines)				
Maximum and minimum voltage				RMM F.5

Multivoltage electronic timers - 22.5mm module

	Supply voltage	Time range	Available contacts	Cat. no	Ref. no.	Pack	
 <p>Delayed ON relay</p>	Direct	0.06 sec - 100 h.	2 changeover	NMTCV 2	124901	1	
	24-240V AC/DC						
Technical data: see F.7							
 <p>Star-delta starter</p>	Direct	1 - 10 sec.	1 changeover	NMETV	124908	1	
	24-240V AC/DC	6 - 60 sec.					
	With transformer ⁽²⁾	1 - 10 sec.	1 changeover	NMETV t AU ⁽¹⁾	124911	1	
		6 - 60 sec.					
Technical data: see F.8							
	Supply voltage	Time range	Available contacts	Cat. no ⁽¹⁾	Ref. no.	Pack	
 <p>Delayed OFF timer</p>	Direct	0.5 - 6 sec.	2 changeover	NMRDV 2-6	124915	1	
	24-240V AC/DC	5 - 60 sec.	2 changeover	NMRDV 2-60	124916	1	
	24-240V AC/DC	50 - 600 sec.	2 changeover	NMRDV 2-600	124917	1	
	Technical data: see F.8						
 <p>Asymmetric intermittence, started by connection or pause (choice)</p>	Direct	0.06 sec - 100 h	1 changeover	NMIVV	124929	1	
	24-240V AC/DC						
Technical data: see F.9							
 <p>Multifunction</p>	<ul style="list-style-type: none"> - Delayed ON timer - Delayed ON through contact timer - Delayed OFF through contact timer - Delayed ON and OFF through contact timer 		<ul style="list-style-type: none"> - Impulse ON timer - Impulse ON through contact timer - Impulse OFF through contact timer - Impulse ON and OFF through contact timer 				
	Module 22,5mm						
	Direct	0.6 sec - 100 h	1 changeover	NMMFV	124930	1	
24-240V AC/DC							
Technical data: see F.10							

(1) AU = coil 380V 50/60 Hz
 (2) Transformer inside the timer housing

Single voltage electronic timers - 45mm module

Motor re-start control relay (plug in)	Supply voltage	Voltage (V)	Available contacts	Time range	Cat. no	Ref. no.	Pack
	Direct ⁽¹⁾			RCRT 1 changeover	0.2 - 6 sec. (memory time) 0.2 - 60 sec. (delayed time)	RCRT 6 - 60AN ⁽²⁾ RCRT 6 - 60AJ ⁽³⁾	123624 123623
Technical data: see F.11							

Liquid level detector relay

Supply voltage	Contacts	No. of circuits	Cat. no.	Ref. no.	Pack
	DINIL ...E 1 changeover	2	DINIL 02E ENU	123656	1
	11 pins socket for DINIL-02E, -03E. for panel fixing. Front terminals		PRCZ11	220647	1
Technical data: F.12					

Probes

Without cable. Waterproof and protected with a thermoplastic housing. Stainless steel probe.	SON-3	123700	1
--	-------	--------	---

Earth leakage relays - 45 mm module

Supply voltage	Contacts	Sensiv. (A)	Ø (mm)	Differential transformers			Earth leakage relays		
				Cat. no	Ref. no.	Pack	Cat. no	Ref. no.	Pack
Differential earth leakage relay with hand reset (with test)	RDHT 1-... With test 1 changeover	0.2 - 1.2	35	WKAT 35-1,2A/2V	204165	1	RDHT 1-1,2AEN ⁽⁴⁾	123744	1
			70	WKAT 70-1,2A/2V	204166	1			
	1 - 10	35	WKAT 35-10A/2V	204169	1	RDHT 1-10AEN ⁽⁴⁾	123754	1	
		70	WKAT 70-10A/2V	204170	1				
Technical data: see F.13									
Differential earth leakage relay with automatic reset (with test)	Direct and with transformer With test 1 changeover	0.2 - 1.2	35	WKAT 35-1,2A/2V	204165	1	RDHA 1-1,2AEU ⁽⁵⁾	123965	1
			70	WKAT 70-1,2A/2V	204166	1			
	1 - 10	35	WKAT 35-10A/2V	204169	1	RDHA 1-10AEN ⁽⁴⁾	123964	1	
		70	WKAT 70-10A/2V	204170	1				
Technical data: see F.13									







(1) Possibility of fitting a remote potentiometer.
 (2) AN = 220V 50/60Hz
 (3) AJ = 110-125V 50/60Hz

(4) EN = coil 220/230V 50/60Hz
 (5) EU = coil 380/400V 50/60Hz

Dimensions ● pg. F.21



Protection relays

	Supply voltage contact	Contacts	Operating range		Unbalance	Mains frequency	Cat. no	Ref. no.	Pack
			Umin.	Umax.					
 <p>Integral protection relay for three-phase lines</p>	With transformer	RDF1 1-... 1 changeover	5 - 20%	5 - 15%	2.5 - 10%	50 Hz	RDF1-50AU ⁽¹⁾	123985	1
	Technical data: see F.14								
 <p>Unbalance and phase failure protection relay for three-phase lines</p>	Direct and with transformer	RPDF 2-... 2 changeover	-	-	2.5 - 10%	50 Hz	RPDF2-50AU ⁽¹⁾	124025	1
	Technical data: see F.15								
 <p>Phase sequence and phase failure protection relay for three-phase lines</p>	With transformer	RSFF 1-... 1 changeover	-	-	-	50 Hz	RSFF1-50AU ⁽¹⁾	124622	1
	Technical data: see F.16								
 <p>Phase sequence protection relay for three-phase lines</p>	With transformer	RSF 1-... 1 changeover	-	-	-	50 Hz	RSF1-50ANU ⁽²⁾	124051	1
	Technical data: see F.16								
 <p>Maximum and minimum voltage protection relay for three-phase lines</p>	With transformer	RTMM 2-... 2 changeover	5 - 20%	5 - 15%	-		RTMM 2 AU	124085	1
							RTMM EN ⁽³⁾	124084	1
	Technical data: see F.17								
 <p>Maximum and minimum voltage protection relay for a single-phase lines</p>	With transformer	RMM 2-... 2 changeover	5 - 20%	5 - 15%	-		RMM 2 EN ⁽³⁾	124104	1
	Technical data: see F.17								

(1) AU = coil 380V 50Hz
 (2) ANU = coil 220-230V 380-400V 50/60Hz
 (3) EN = coil 220/230V 50/60Hz

A

B

C

D

E

F



G

H



I

X

Detection relays

	Supply voltage	Contacts	Operating range	Voltage drop	Input impedance	Max. input voltage	Cat. no	Ref. no.	Pack
Voltage detector relay 	Direct and with transformer	RDT 2-... 2 changeover	40 - 400V	-	800 kΩ	600V	RDT2400VEN ⁽¹⁾	124184	1
	Technical data: see F.18								
Current detector with delay (0.5 - 15 sec.) 	Direct and with transformer	RDIT 2-... 2 changeover	0.5 - 5A 20 - 200mV	0.25V	0.05Ω 1 kΩ	10A 15V	RDIT2-5AEN ⁽¹⁾ RDIT2-02VEN ⁽¹⁾	124754 124354	1 1
	Technical data: see F.18								

Control and protection relays

	Supply voltage	Contacts	Thermal probe ⁽⁵⁾ When cold - When hot			Cat. no	Ref. no.	Pack	
Thermistor relay 	Direct and with transformer ⁽⁴⁾	RS01N 1 changeover	1.5 kΩ -	2.5 kΩ		RS01NEN ⁽¹⁾ RS01NAJ ⁽²⁾	212759 124373	1 1	
	Technical data: see F.19								
Frequency control relay 	Supply voltage	Contacts			Jumper terminals	Setting range	Cat. no	Ref. no.	Pack
	With transformer ⁽⁴⁾	RCF 1-... 1 changeover			Without Y1 - Y2 Y1 - Y3	5 - 15Hz 15 - 45Hz 45 - 135Hz	RCF-1 AJ ⁽²⁾ RCF-1 EN ⁽¹⁾ RCF-1 AU ⁽³⁾	124433 124434 124435	1 1 1
	Technical data: see F.20								

- (1) EN = coil 220/230V 50/60Hz
- (2) AJ = coil 110V 50/60Hz
- (3) AU = coil 380/400V 50/60Hz
- (4) Transformer inside the timerhousing
- (5) Thermal probe resistance not included

Dimensions ● pg. F.21

NMTCV2 Delayed ON timer

Function

Electronic relay whose output contact connects with a certain adjustable delay from the moment voltage is applied to supply terminals **A1-A2**.

It has seven timing ranges : see drawing. ①

Range selection is made by dipperswitches located on the front of the relay. Times are set by front potentiometer controlling an Application Specific Integrated Circuit (ASIC) specially designed for this group of relays. This allows for excellent precision and repeatability features.

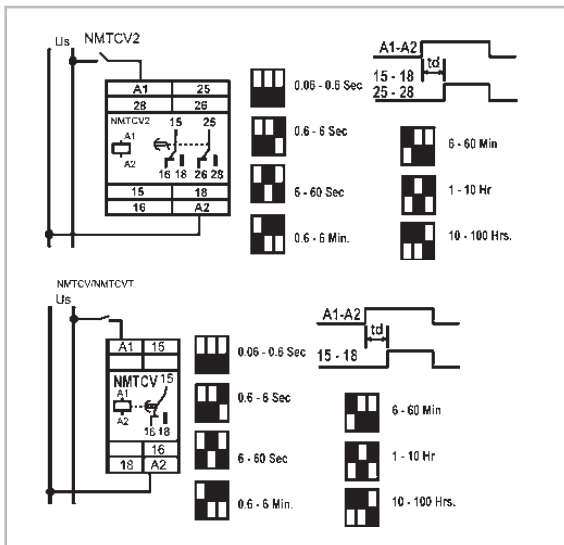

① 0.06 - 0.6s, 0.6 - 6s, 6 - 60s, 0.6 - 6 min, 6 - 60 min, 1 - 10h, 10 - 100h

Technical characteristics

		NMTCV2
Nr. of changeover contacts		2
Output contacts:		
Rated insulation voltage U_i	AC (V)	250
	DC (V)	250
Thermal current I_{th}	(A)	6
Utilisation AC-15		
Rated voltage U_e	(V)	120/230
Rated current I_e	(A)	2.5/1.3
Utilisation DC-13		
Rated voltage U_e	(V)	110/230
Rated current I_e	(A)	0.2/0.1
Supply voltages (U_n)		
AC/DC (direct)	(V)	24-240
AC(with transformer)	(V)	-
Frequency	(Hz)	50/60
Supply voltage tolerance	(%)	+10 / -20
Consumption	(mA)	60 (24V)
	(mA)	15 (240V)
	(VA)	-
Input circuit test voltage (between input, output and group circuits)	(kV)	4
Switch ON response time		0.06s - 100 h.
Switch OFF response time	(ms)	150
Reset time between 2 cycles ⁽¹⁾	(ms)	100
Repeat accuracy with 0.85 - 1.1 U_n	(%)	1

Electronic relays of 22.5 mm

A

B

C

D

E

F

G

H

I

X

Ambient conditions

Storage temperature	-40°C to +80°C
Operating temperature	-25°C to +60°C
Relative humidity	95% (without condensation)
Max. operating altitude	2.000 m
Degree of protection	IP40; terminals IP20
Operating positions	Any position

Conformity to standards

VDE 0106	CSA C 22.2 No 14
VDE 0110	IEC/EN 60255-5
EN 50002	UL 94
EN 50042	UL 508
IEC/EN 60947-5-1	UNE 20-119
CE	

(1) Reset time: Time that must go by from the relay ends an operation until it is able to initiate the next one without error.

Remark

The relay has a green LED that lights when the relay is energised (flashing during the timing) and a red LED that lights when output contact is made.



NMETV... Star-delta starter timer

Function

Electronic relay timed in steps whose purpose is to control star-delta starting. When supply voltage is applied to the **A1-A2** terminals, the star contact (17-18) closes for an adjustable time between up to 100 h (selectable) When this time is up, it opens, there is a pause and then the delta contact connects (17-18). The standard pause time is about 100ms.

Times are set by front potentiometer controlling an ASIC specially designed for this group of relays. This allows for excellent precision and repeatability features.

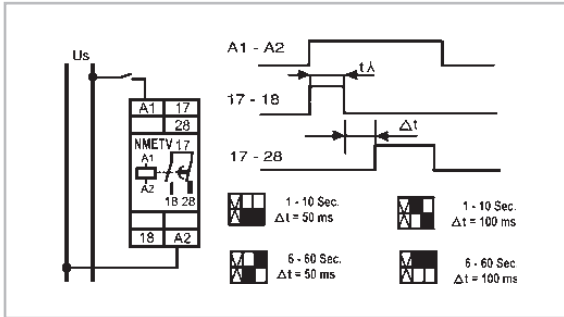

Technical characteristics

	METV	METV t
Nr. of changeover contacts	2	
Output contacts:		
Rated insulation voltage Ui	AC (V)	250
	DC (V)	250
Thermal current Ith	(A)	6
Utilisation AC-15		
Rated voltage Ue	(V)	125/230
Rated current Ie	(A)	2.5/1.3
Utilisation DC-13		
Rated voltage Ue	(V)	110/230
Rated current Ie	(A)	0.2/0.1
Supply voltages (Un)		
AC/DC (direct)	(V)	24-240
AC(with transformer)	(V)	- 110-125 200-240 380-440
Frequency	(Hz)	50/60
Supply voltage tolerance	(%)	+10 / -20 +10 / -15
Consumption	(mA)	50 (at 24V) -
	(mA)	12 (at 240V) -
	(VA)	- 3.5
Test voltage	(kV)	4
(between input, output and ground)		
Switch ON response time	(ms)	100
Reset time between 2 cycles ⁽¹⁾	(ms)	100
Repeat accuracy with 0.85 - 1.1 Un(%)		2

Ambient conditions

Storage temperature	-40°C to +80°C
Operating temperature	-25°C to +60°C
Relative humidity	95% (without condensation)
Max. operating altitude	2.000 m
Degree of protection	IP40; terminals IP20
Operating positions	Any position

Conformity to standards

VDE 0106	CSA C 22.2 No 14
VDE 0110	IEC/EN 60255-5
EN 50001 (NMETV)	UL 94
EN 50002	UL 508
EN 50042 (NMRDV)	UNE 20-119 (NMRDV)
IEC/EN 60947-5-1 (NMRDV)	CE

NMRDV... Delayed OFF timer

Function

Electronic relay whose output contact instantly connects when supply voltage is applied to terminals **A1-A2**. It disconnects with an adjustable delay as from the moment the relay loses supply voltage. There are several types depending on the range of timers.

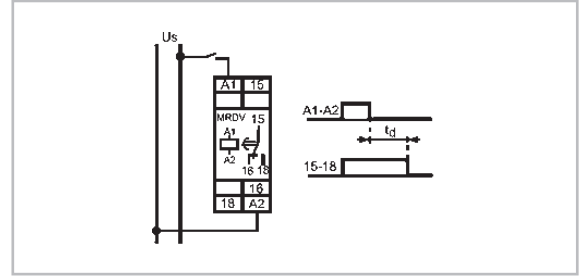

Technical characteristics

	NMRDV2
Nr. of changeover contacts	2
Output contacts:	
Rated insulation voltage Ui	AC (V) 250
	DC (V) 250
Thermal current Ith	(A) 6
Utilisation AC-15	
Rated voltage Ue	(V) 125/230
Rated current Ie	(A) 2.5/1.3
Utilisation DC-13	
Rated voltage Ue	(V) 110/230
Rated current Ie	(A) 0.2/0.1
Supply voltages (Un)	
AC/DC (direct)	(V) 24-240
AC(with transformer)	(V) - 200-240 380-440
Frequency	(Hz) 50/60
Supply voltage tolerance	(%) +10 / -20
Consumption	(mA) 1,5 (at 24V)
	(mA) 5 (at 240V)
	(VA) -
Test voltage	(kV) 4
(between input, output and ground)	
Switch ON response time	(ms) 250 ⁽²⁾
Switch OFF response time	0.5 - 600
Reset time between 2 cycles ⁽¹⁾	(ms) 250
Repeat accuracy with 0.85 - 1.1 Un(%)	5

- (1) Reset time: Time that must go by from the relay ends an operation until it is able to initiate the next one without error.
- (2) For 24V c.c. = 300ms

Remark

METV relays have a green LED that lights up when the relays is energised (flashing during the timing) and a red LED that lights up when the star contact 17-18 is closed.

NMIVV Asymmetric intermittence, started by connection or pause (choice)

Function

Electronic relay whose output contact connects and disconnects intermittently. Connection and pause times may be separately. The intermittency cycle begins a connection or disconnection selected by a dip-switches and start the instant connection is made from supply voltage to the **A1-A2** terminals. A new step is begun if voltage supply is interrupted during operation. It has four timing ranges ;
 MIVV : 0,6 sec - 100 h
 Range selection is made by dip-switches located on the front of the relay. Times are set by front potentiometer an ASIC specially designed for this group of relays. This allows for excellent precision and repeatability features.

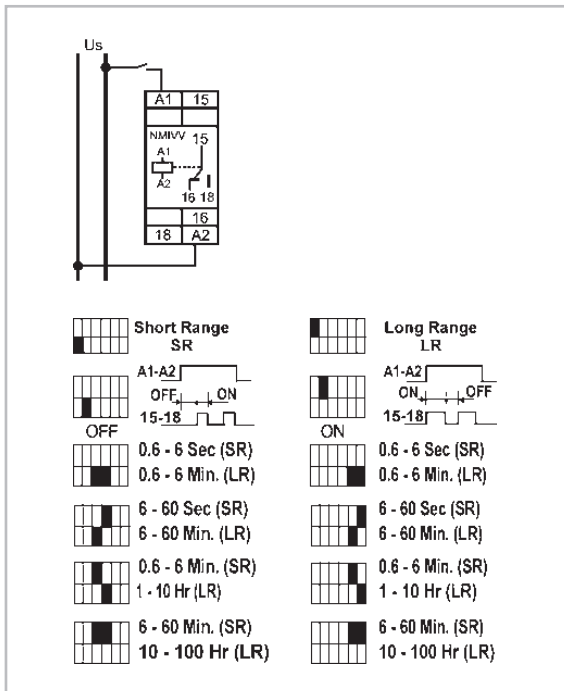

Technical characteristics

		NMIVV	
Nr. of changeover contacts		1	
Output contacts:			
Rated insulation voltage U_i	AC (V)	250	
	DC (V)	50	
Thermal current I_{th}	(A)	6	
Utilisation AC-15			
Rated voltage U_e	(V)	125/230	
Rated current I_e	(A)	2,5/1,3	
Utilisation DC-13			
Rated voltage U_e	(V)	110/230	
Rated current I_e	(A)	0,2/0,1	
Supply voltages (U_n)			
AC/DC (direct)	(V)	24-240	
Frequency	(Hz)	50/60	
Supply voltage tolerance	(%)	+10 / -20	
Consumption	(mA)	60 (at 24V)	
	(mA)	15 (at 240V)	
	(VA)	-	
Test voltage	(kV)	2	
(between input, output and ground circuits)			
Switch ON response time	(ms)	150	
Intermittent switch ON times ⁽²⁾		0,6 s - 100 h.	
Intermittent switch ON times ⁽²⁾		0,6 s - 100 h.	
Reset time between 2 cycles ⁽¹⁾	(ms)	150	
Repeat accuracy with 0.85 - 1.1 U_n (%)		1	

Electronic relays of 22.5 mm

A

B

C

D

E

F

G

H

I

X

Ambient conditions

Storage temperature	-40°C to +80°C
Operating temperature	-25°C to +60°C
Relative humidity	95% (without condensation)
Max. operating altitude	2.000 m
Degree of protection	IP40; terminals IP20
Operating positions	Any position

Conformity to standards

VDE 0106	CSA C 22.2 No 14
VDE 0110	IEC/EN 60255-5
EN 50002	UL 94
EN 50005	UL 508
EN 50042	UNE 20-119
IEC/EN 60947-5-1	CE

- (1) Reset time: Time that must go by from the relay ends an operation until it is able to initiate the next one without error.
- (2) Connection and pause times be set within different ranges.

Remark

These relays has a green LED that lights up when the relays is energised (flashing during the timing) and a red LED that lights up when output contact is made.



NMMFV Multifunction relay

Function

The functions of this multifunction and multirange electronic relay are selected by 3 dip-switches located on the front of the relay. It has eight functions: delayed ON timer, delayed ON through contact timer, delayed OFF through contact timer, delayed ON and OFF through contact timer, impulse ON timer, impulse ON through contact timer, impulse OFF through contact timer, impulse ON and OFF through contact timer. If the relay loses current during timing, it disconnects and is ready for a new cycle. It has four timing ranges: see drawing. Range selection is made by dip-switches located on front of the relay. Times are set by front potentiometer controlling an ASIC specially designed for this group of relays. This allows for excellent precision and repeatability features.

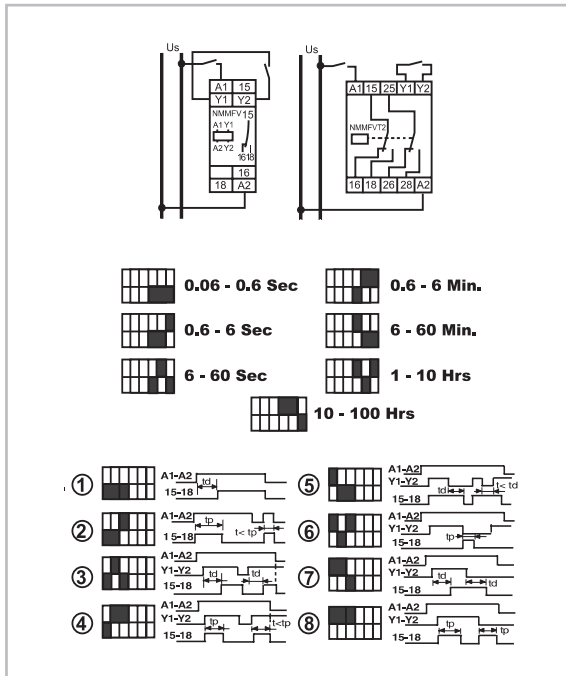

Technical characteristics

		NMMFV
Nr. of changeover contacts		1
Output contacts:		
Rated insulation voltage Ui	AC (V)	250
	DC (V)	250
Thermal current Ith	(A)	6
Utilisation AC-15		
Rated voltage Ue	(V)	110/230
Rated current Ie	(A)	2.5/1.3
Utilisation DC-13		
Rated voltage Ue	(V)	110/230
Rated current Ie	(A)	0.2/0.1
Supply voltages (Un)		
AC/DC (direct)	(V)	24-240
Frequency	(Hz)	50/60
Supply voltage tolerance	(%)	+10 / -20
Consumption (mA)		60 (at 24V)
	(mA)	15 (at 240V)
	(VA)	-
Test voltage (between input, output and ground circuit)	(kV)	2
Switch ON response time		0.065 s - 100 h.
Switch OFF response time		0.065 s - 100 h.
Reset time between 2 cycles ⁽¹⁾	(ms)	150
Repeat accuracy with 0.85 - 1.1 Un(%)		1
Voltage open Y1-Y2 (control contact terminals)	(V DC)	5
Current through control contact		
Initial	(mA)	15
Permanent	(mA)	1

Ambient conditions

Storage temperature	-40°C to +80°C
Operating temperature	-25°C to +60°C
Relative humidity	95% (without condensation)
Max. operating altitude	2,000 m
Degree of protection	IP40; terminals IP20
Operating positions	Any position

Conformity to standards

VDE 0106	CSA C 22.2 No 14
VDE 0110	IEC/EN 60255-5
EN 50002	UL 94
EN 50042	UL 508
IEC/EN 60947-5-1	UNE 20-119
CE	

(1) Reset time: Time that must go by from the relay ends an operation until it is able to initiate the next one without error.

Remark

The relays have a green LED that lights up when the relays is energised (flashing during the timing) and a red LED that lights up when output contact is made.

RCRT... Motor re-start control relay (plug-in)

Function

RCRT...

The relay is used for instantaneous or delayed motor startup after a short-time power failure (max. 6 sec). The start occurs immediately if power supply is disrupted for less than 0.2 sec. If the power failure lasts longer, the relay activates its memory for a time that can be set to 0.2 to 6 sec, after which no automatic restart is possible. If power supply is restored while the memory period is elapsing, the relay commands a motor restart with a delay time from power supply restoration that can be set to 0.2 to 60 sec. A system stop cancels the memory function after 50 ms, and therefore the stop signal should be on for at least this time. The relay is non-sensitive to any control voltage fluctuation or disruption during or after the motor stop.

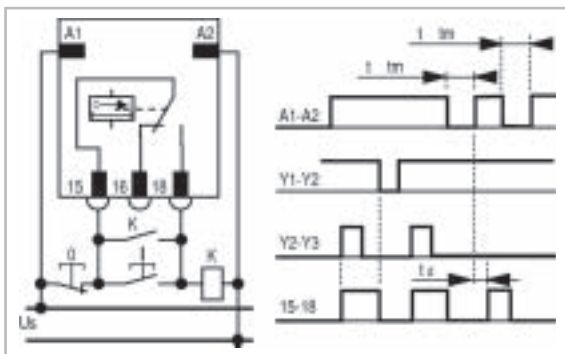

Technical characteristics

		RCRT 6-60
Nr. of changeover contacts		1
Output contacts:		
Rated insulation voltage U _i	AC (V)	400
	DC (V)	250
Thermal current I _{th}	(A)	6
Utilisation AC-15		
Rated voltage U _e	(V)	120/240
Rated current I _e	(A)	2.5/1.3
Utilisation DC-13		
Rated voltage U _e	(V)	110/220
Rated current I _e	(A)	0.2/0.1
Supply voltages (U _n)		
AC	(V)	110, 220-230, 125
Frequency	(Hz)	50/60
Permissible supply voltage variation (%)		+10 / -15
Repeat accuracy with 0.85 - 1.1 U _n (%)		2
Consumption	(VA)	3
Input circuit test voltage	(kV)	4
(between input, output circuit and earth)		
Switch ON response time	(ms)	100
Power failure detection level		0.8 U _s
Reset ime (stop)	(ms)	50 - 75
Memory reset time	(ms)	100
Max. restart delay time	(s)	0.2 - 60
Max. memory time	(s)	0.2 - 6

Ambient conditions

Storage temperature	-10°C to +85°C
Operating temperature	-5°C to +50°C
Relative humidity	95% (without condensation)
Max. operating altitude	2.000 m
Degree of protection	IP40; terminals IP20
Operating positions	Any position

Conformity to standards

VDE 0106	IEC/EN 60947-5-1
EN 50001	UNE 20-119
EN 50005	CE
EN 50011	
DIN 46199	

Remark

The relay has one LED that lights up when the contact is made.

DINIL 02E Liquid level detector relay for simultaneous control of well and tank

Functions

Plug-in devices for control of level of conductive liquids which can perform the following functions:

Filling control: The contact between **1** and **3** closes when the tank to be checked drops below a minimum, fixed by the position of probe **6**, which starts up the pumping system. When the maximum filling level is reached, fixed by the position of probe **7**, the contact between **1** and **3**, opens and the pumping system stops. For the filling control the two well probes must be connected externally to the common one (condition of full well).

Draining control: The contact **1-3** closes if the level liquid goes above a maximum, fixed by the position of probe **9**, which starts up the drain pumping system. When the level drops below a minimum, fixed by the position of probe **8** the contact **1-3** opens and stop the pumping system, which prevents the pumpo from losing its prime.

Simultaneous filling and draining control: The system starts up whenever the tank requires liquid and the well has sufficient level to supply it, and it stops when the liquid reaches its maximum level in the tank or, as the case may be, the well reaches its minimum level.

Remark: In all the above applications, the contact between **1-3** is used as a permanent contact for starting and stopping the pump starter, whether this is DOL, star-delta or any other type of starter.

Control voltage: Two voltages:
 terminals 2-10 (220 VAC)
 terminals 2-11 (380 VAC)

Technical characteristics

		DINIL-02E	
Nr. of changeover contacts		1	
Output contacts:			
Rated insulation voltage U_i	AC (V)	400	
	DC (V)	250	
Thermal current I_{th}	(A)	6	
Utilisation AC-15			
Rated voltage U_e	(V)	120/240	
Rated current I_e	(A)	2.5/1.3	
Utilisation DC-13			
Rated voltage U_e	(V)	110/220	
Rated current I_e	(A)	0.2/0.1	
Supply voltages (U_n)			
AC (with transformer)	(V)	380-400/220-230 (two voltages)	
Frequency	(Hz)	50/60	
Permissible supply voltage variation (%)		+10 / -15	
Repeat accuracy with 0.85-1.1 U_n (%)		2	
Consumption	(VA)	3	
Input circuit test voltage (between input, output circuit and earth)	(kV)	4	
Voltage between probes and common	(V ef.)	6 - 18	
Max. consumption of probes	(mA ef.)	0,18	
Max. resistance between probes (resistance of controlled liquid)	(kOhms)	200	
Switch ON response time	(s)	1	
Switch OFF response time	(s)	1	

DINIL-02E - Filling control

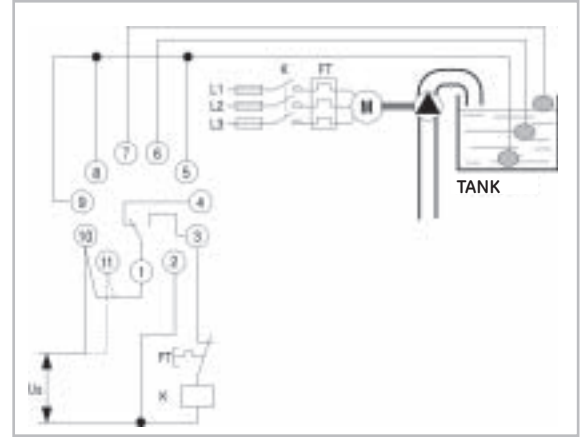

DINIL-02E - Draining control

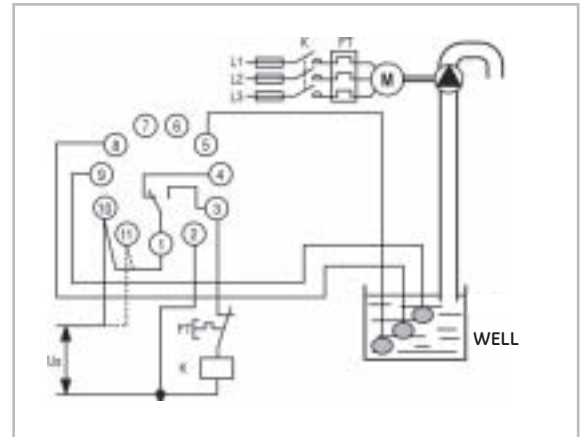

DINIL-02E - Simultaneous filling and draining control

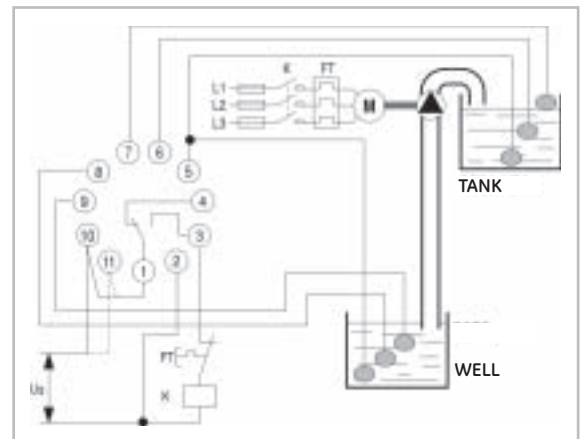

Ambient conditions

Storage temperature	-10°C to +85°C
Operating temperature	-5°C to +50°C
Relative humidity	95% (without condensation)
Maximum operating altitude	2.000 m
Degree of protection	IP40; terminals IP20
Operating positions	Any

Conformity to standards

VDE 0106 IEC/EN 60947-5-1 CE UNE 20119

Remark

The relays has one LED that lights up when the output contact is made.

RDHT..., RDHA... Earth leakage relays

RDHT... Earth leakage relay with manual reset, with test
RDHA... Earth leakage relay with automatic reset, with test

Function

RDH, RDHT and RDHA are earth leakage detectors for industrial networks with neutral connected to earth, used with WKA (without test) and WKAT (with test) differential transformers. Tripping is produced when leakage current exceeds a threshold which is adjustable by means of a front mounted potentiometer. Tripping ranges are shown in the table below.

RDH and RDHT keep memory of tripping even in the absence of voltage in **A1** and **A2** and resetting is obtained from a push-button. RDHA is self resetting in the absence of control voltage in **A1** and **A2** or when leakage disappears. RDHT and RDHA have in addition a test push-button for control from cubicle door, and therefore those relays should always be use with WKAT transformers with test winding. All types have included a timer, with external ajustement in RDHA and internal ajustement in RDH and RDHT that allows to delay the trip to achieve trip selectivity.

RDHT1-... RDHA1-...	Sensitivity	Transformers		Ø
... 1,2	0.2 - 1.2A	WKAT-35	1.2A/2V	35
		WKAT-70	1.2A/2V	70
... 10	1 - 10A	WKAT-35	10A/2V	35
		WKAT-70	10A/2V	70

Ambient conditions

Storage temperature	-10°C to +85°C
Operating temperature	0°C to +50°C
Relative humidity	95% (without condensation)
Altitude	2.000 m
Degree of protection	IP40; terminals IP20
Operating positions	Any

Conformity to standards

VDE 0106	IEC/EN 60947-5-1
EN 50001	UNE 20-119
EN 50005	CE
EN 50011	
DIN 46199	

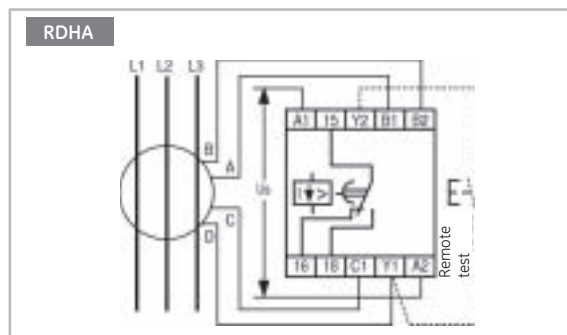
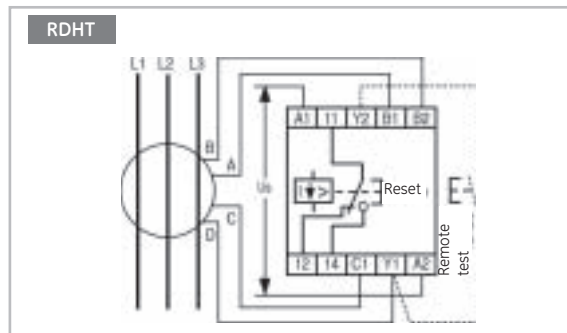
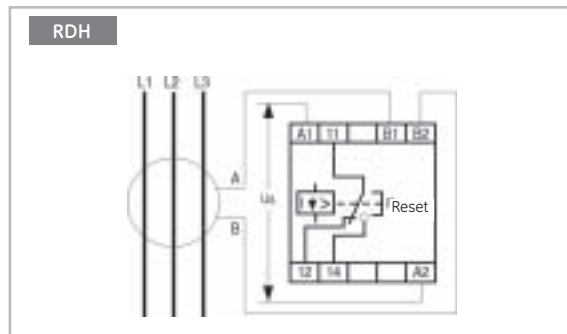

Technical characteristics

	RDHT1-...	RDHA1-...
Nr. of changeover contacts	1	
Output contacts:		
Rated insulation voltage Ui	AC (V)	400
	DC (V)	250
Thermal current Ith	(A)	6
Utilisation AC-15		
Rated voltage Ue	(V)	120/240
Rated current Ie	(A)	2.5/1.3
Utilisation DC-13		
Rated voltage Ue	(V)	110/220
Rated current Ie	(A)	0.2/0.1
Supply voltages (Un)		
AC (with transformer)	(V)	380-400
		220-230
DC/AC (direct)	(V)	-
Frequency	(Hz)	50/60
Permissible supply voltage variation (%)	+10 / -15	
Repeat accuracy with 0.85-1.1 Un (%)	2	
Consumption (VA)	3	
Input circuit test voltage (kV)	4	
(between input, output circuit and earth)		
Switch ON response time (s)	150-200	100
(can be delayed up to 5 sec)		

RDF1... Integral protection relay for three-phase lines

Function

Protection against:

- a) Phase failure
- b) Phase sequence
- c) Phase unbalance
- d) Low line voltage
- e) High line voltage

Relay operates by phase angle detection between voltages and not by voltage levels and therefore will drive satisfactorily even with feedback from other motors.

Relays will connect only when all conditions are normal (contact 15-18 closes) and disconnects on any fault including supply, protecting network even with supply failure. It will not connect if phase sequence is incorrect, preventing motors starting in wrong direction.

Unbalance adjustment

Phase, unbalance, and therefore single phase is very dangerous for the life of a motor. The graph below shows temperature rise in a three-phase motor with a phase unbalance (NEMA MG 1-1433 and 34). The per cent unbalance is obtained as follow:

$$\% \text{ unbalance} = \frac{\text{Max. voltage deviation from average voltage}}{\text{average voltage}} \times 100$$

Tripping is adjustable between 2.5 and 10 %.

Consequently protection is provided for motors working closely adjusted to rated power, to others more generously sized, and even power lines.

In any case adjustments should be made so that on failure of one phase relay will disconnect.

Voltage adjustment

Voltage tripping is adjustable from -5 to -20 % and +5 to +15 % maximum by which it is possible to adjust to values recommended by IEC 34.1 (1969) and IEC 158 respectively. Tripping for these causes is delayed 1 second approximately.

Tripping indication

Relays incorporate LED diode tripping indication. When phase sequence is incorrect, both phase sequence and unbalance light up. When unbalance lights up only indicates unbalance or single phasing with feedback.

Ambient conditions

Storage temperature	-10°C to +85°C
Operating temperature	-5°C to +50°C
Relative humidity	95% (without condensation)
Altitude	2.000 m
Degree of protection	IP40; terminals IP20
Operating positions	Any

Conformity to standards

VDE 0106	DIN 46199	IEC/EN 60947-5-1
EN 50001	UNE 20-119	CE
EN 50005		
EN 50011		

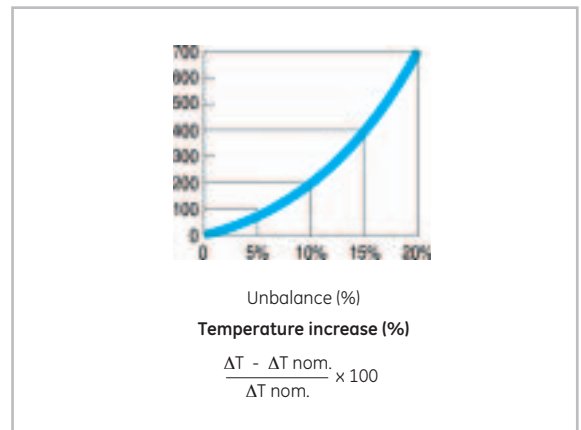
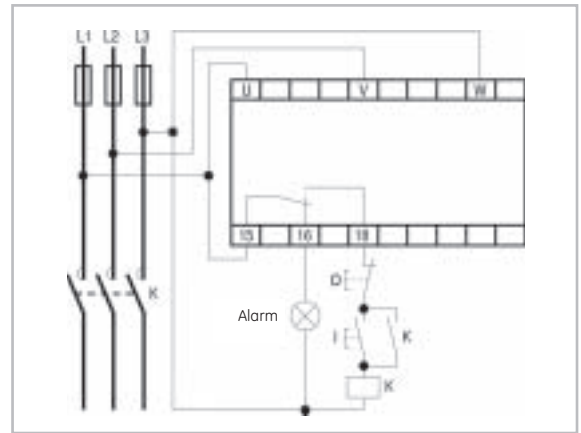

Technical characteristics

		RDF1-5
Nr. of changeover contacts		1
Output contacts:		
Rated insulation voltage U_i	AC (V)	400
	DC (V)	250
Thermal current I_{th}	(A)	6
Utilisation AC-15		
Rated voltage U_e	(V)	120/240
Rated current I_e	(A)	2.5/1.3
Utilisation DC-13		
Rated voltage U_e	(V)	110/220
Rated current I_e	(A)	0,2/0,1
Supply voltages (U_n)		
AC (with transformer)	(V)	380
Frequency	(Hz)	50
Permissible supply voltage variation (%)		+15 / -20
Repeat accuracy with 0.85 - 1.1 U_n	(%)	2
Consumption	(VA)	3
Input circuit test voltage	(kV)	4
(between input, output circuit and earth)		
Unbalance tripping (adjustable)	(%)	2.5 to 10
Low voltage tripping (adjustable)	(%)	5 to 20
Overvoltage tripping (adjustable)	(%)	5 to 15
Switch ON response time	(ms)	200
Reset hysteresis	(%)	5 approx.

RPDF... Unbalance and phase failure protection relay for three-phase lines

Function

The RPDF-electronic relay is intended for the protection of lines or electronic motors against unbalance between phases or failure of one or more phases. Detection of unbalance or phase failure is done by measuring phase change and not by voltage levels. This guarantees correct working even when there are return paths due to motors running which are connected to the mains networks to be protected. The relay is made when all conditions are normal (contact **11-14** closed); the contacts open in the event of a failure. In this way, any failure, including that of the relay supply, will cause disconnection and so avoid the supply being left unprotected.

Setting unbalance

The unbalance in phases and, consequently, the failure of one of these, is a limiting factor in the life of an electric motor. The graph below shows the percentage temperature increase in a three-phase motor as a function of the degree of unbalance (see standards NEMA MG 1-1433 and 34). The per cent unbalance is calculated as follows :

$$\% \text{ unbalance} = \frac{\text{Max. voltage deviation from average voltage}}{\text{average voltage}} \times 100$$

The trip is adjustable between about 2.5% and 10%. Consequently protection is provided for motors working closely adjusted to rated power, to others more generously sized, and even power lines. In any case, the adjustment must be such that the loss of a phase produces the opening of the relay.

Ambient conditions

Storage temperature	-10°C to +85°C
Operating temperature	-5°C to +50°C
Relative humidity	95% (without condensation)
Altitude	2.000 m
Degree of protection	IP40; terminals IP20
Operating positions	Any

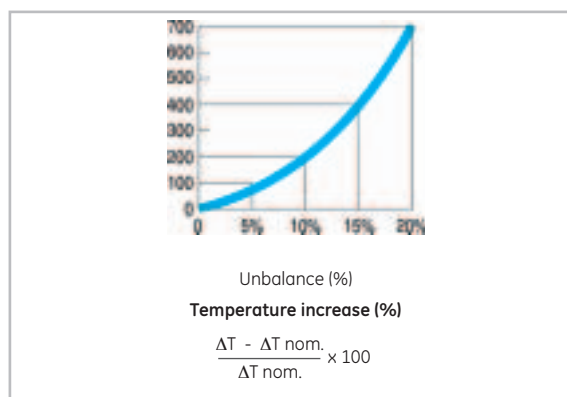
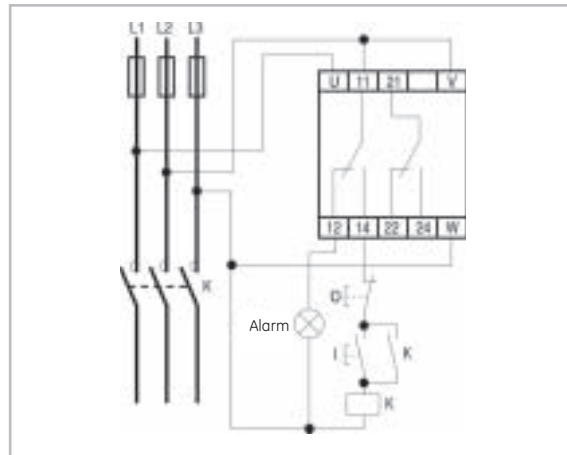

Technical characteristics

	RPDF 2-50
Nr. of changeover contacts	2
Output contacts:	
Rated insulation voltage U_i	AC (V) 400 DC (V) 250
Thermal current I_{th}	(A) 6
Utilisation AC-15	
Rated voltage U_e	(V) 120/240
Rated current I_e	(A) 2.5/1.3
Utilisation DC-13	
Rated voltage U_e	(V) 110/220
Rated current I_e	(A) 0,2/0,1
Supply voltages	(U_n)
AC (with transformer)	(V) 380
Frequency	(Hz) 50
Permissible supply voltage variation	+10 / -20 (%)
Repeat accuracy	(%) 2
Consumption	(VA) 3
Input circuit test voltage	(kV) 4
(between input, output circuit and earth)	
Unbalance tripping (adjustable)	(%) 2.5 to 10
Switch ON response time	(ms) 100
Reset hysteresis	(%) 2

Conformity to standards

VDE 0106	IEC/EN 60947-5-1
EN 50001	UNE 20-119
EN 50005	CE
EN 50011	
DIN 46199	

RSFF... Phase sequence and phase failure protection relay for three-phase lines

Function

The RSFF relay is designed to detect phase sequence errors and/or phase failures in three phase lines. Three terminals **U, V, W** are connected to each of the three phases of the mains. Controlling vectors of voltage between lines (amplitude and phase) is detected the direct sequence (phase **V** with 120° in respect of **U** and phase **W** with 240° lag in respect and phase **U**) as well as balance of voltages and angles of phases, for detecting a phase failure even with returns (motor working).

By means of an external potentiometer can be adjusted the network unbalance, level, between 2,5 % and 105 % to adapt the relays sensibility for phase failure function. This unbalance is measured according to NEMA MG1-1433 and 34, and corresponds to a fall of simple tension of phase in amplitude of 7.3 and 28%, respectively. The relay precives either increases or drops of voltage and angle, then it detect the failures even in motors working as breaking devices (loads going down in lifting devices). When relay is powered, it connects instantaneously (max. 200ms) if the power system is correct. Once the switched on relay is switch-on, it switches-off with 1 sec. delay in case of a failure, to avoid false disconnections due to transient unbalances. (Start of other motors, transformers, etc.).

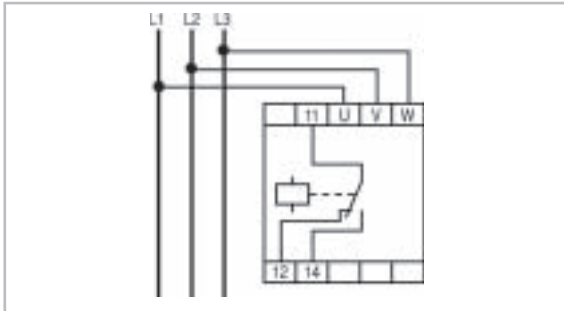

Technical characteristics

		RSFF1-50
Nr. of changeover contacts		1
Output contacts:		
Rated insulation	AC (V)	400
voltage U_i	DC (V)	250
Thermal current I_{th}	(A)	6
Utilisation AC-15		
Rated voltage U_e	(V)	120/240
Rated current I_e	(A)	2.5/1.3
Utilisation DC-13		
Rated voltage U_e	(V)	110/220
Rated current I_e	(A)	0.2/0.1
Supply voltages (Un)		
AC (with transformer)	(V)	380-400
Frequency	(Hz)	50
Permissible supply voltage variation (%)		+15 / -20
Repeat accuracy	(%)	2
Consumption	(VA)	3
Input circuit test voltage	(kV)	4
(between input, output circuit and earth)		
Switch ON response time	(ms)	200
Switch OFF response time	(s)	1

$$\% \text{ unbalance} = \frac{\text{max. voltage derivation from average voltage}}{\text{average voltage}} \times 100$$

RSF... Phase sequence relay for three-phase lines

Function

The RSF1 is designed to detect phase sequence in three phase power system. Three supplies **U, V, W**, take voltage from each of the phases of the network. When phase sequence supplying relay is direct (Phase **V** with 120° lag in respect of **U** and phase **W** with 120° lag in respect of **V**) the relays connects with supply (closes contact between **11-14**) and if no it remains OFF. For correct operation, relay must have supplying each of the three phases.

A phase failure, when there is a return current (the motor is rotating), is not detected by the relay and may lead to a relay malfunction.

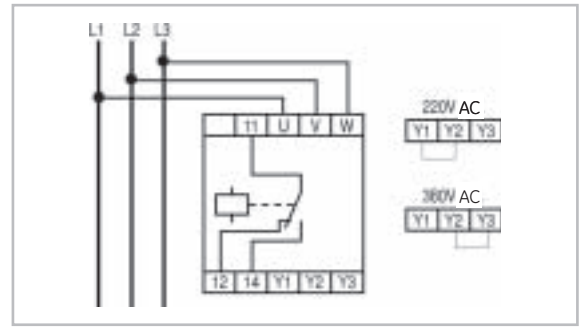

Technical characteristics

		RSF1-50
Nr. of changeover contacts		1
Output contacts:		
Rated insulation	AC (V)	400
voltage U_i	DC (V)	250
Thermal current I_{th}	(A)	6
Utilisation AC-15		
Rated voltage U_e	(V)	120/240
Rated current I_e	(A)	2.5/1.3
Utilisation DC-13		
Rated voltage U_e	(V)	110/220
Rated current I_e	(A)	0.2/0.1
Supply voltages (Un)		
AC (with transformer)	(V)	380-400 / 220-230 (two voltages)
Frequency	(Hz)	50
Permissible supply voltage variation (%)		+10 / -15
Repeat accuracy	(%)	2
Consumption	(VA)	3
Input circuit test voltage	(kV)	4
(between input, output circuit and earth)		
Switch ON response time	(ms)	500
Switch OFF response time	(ms)	200

Ambient conditions

Storage temperature	-10°C to +85°C
Operating temperature	-5°C to +50°C
Relative humidity	95% (without condensation)
Altitude	2.000 m
Degree of protection	IP40; terminals IP20
Operating positions	Any

Conformity to standards

VDE 0106	IEC/EN 60947-5-1	EN 50001	UNE 20-119
EN 50005	EN 50011	DIN 46199	CE

Remark

The relay has one LED that lights when the output contact is made.

RTMM2 Maximum and minimum voltage protection relay for three-phase lines

Function

The RTMM electronic relay is voltage sensitive and has one or two changeover output contacts. The relay maintains operated (contact between 11-14 or between 21-24 closed) while the voltage is within the tolerance limits and opens when these limits are surpassed in plus or minus. The relay can be used for low voltage or over-voltage detection in three-phase lines.

The trip value, for maximum and minimum voltage, are set by means of two independent potentiometer mounted on the relay front cover. The limits for the trip are adjustable between +5 and +15% for maximum voltage and between -5 and -20% for minimum voltage.

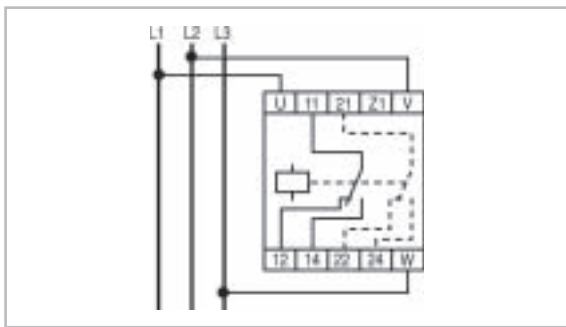

Technical characteristics

		RTMM2
Nr. of changeover contacts		2
Output contacts:		
Rated insulation voltage U_i	AC (V)	400
	DC (V)	250
Thermal current I_{th}	(A)	6
Utilisation AC-15		
Rated voltage U_e	(V)	120/240
Rated current I_e	(A)	2.5/1.3
Utilisation DC-13		
Rated voltage U_e	(V)	110/220
Rated current I_e	(A)	0.2/0.1
Supply voltages (Un)		
AC (with transformer)	(V)	400,380,240,220
Frequency	(Hz)	50/60
Permissible supply voltage variation (%)		+20 / -20
Repeat accuracy (%)		2
Consumption (VA)		3
Input circuit test voltage (between input, output circuit and earth)	(kV)	4
Low voltage tripping (adjustable) (%)		-5 to -20
Over voltage tripping (adjustable) (%)		+5 to +15
Switch ON response time (ms)		100
Reset hysteresis (%)		2

Ambient conditions

Storage temperature	-10°C to +85°C
Operating temperature	-5°C to +50°C
Relative humidity	95% (without condensation)
Altitude	2,000 m
Degree of protection	IP40; terminals IP20
Operating positions	Any

Conformity to standard

VDE 0106	IEC/EN 60947-5-1
EN 50001	UNE 20-119
EN 50005	CE
EN 50011	
DIN 46199	

Remark

The relay has one LED that lights when the output contact is made.

RMM2 Maximum and minimum voltage relay for single-phase lines

Function

These voltage-sensitive relays with one or two changeover output contacts remain connected (contact between 11-14 or between 21-24 closed) when voltage is within tolerance limits, and opens when voltage surpasses these limits in plus or minus. Relays can be used to detect low or lower voltage in balanced single or three-phase systems, and maximum and minimum tripping values are adjustable by means of two frontal potentiometers. The limits for the trip are adjustable between 5 and 15% for maximum voltage and between 5 and 20% for minimum voltage.

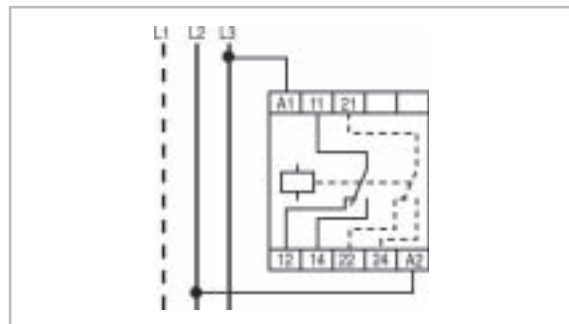

Technical characteristics

		RMM 2
Nr. of changeover contacts		2
Output contacts:		
Rated insulation voltage U_i	AC (V)	400
	DC (V)	250
Thermal current I_{th}	(A)	6
Utilisation AC-15		
Rated voltage U_e	(V)	120/240
Rated current I_e	(A)	2.5/1.3
Utilisation DC-13		
Rated voltage U_e	(V)	110/220
Rated current I_e	(A)	0.2/0.1
Supply voltages (Un)		
AC	(V)	240,220
Frequency	(Hz)	50/60
Permissible supply voltage variation (%)		+15 / -20
Repeat accuracy (%)		2
Consumption (VA)		3
Input circuit test voltage (between input, output circuit and earth)	(kV)	4
Low voltage tripping (adjustable) (%)		-5 to -20
Over voltage tripping (adjustable) (%)		+5 to +15
Reset hysteresis (%)		5 approx.
Switch ON response time (ms)		100

A

B

C

D

E

F

G

H

I

X

RDT2 Voltage detector relay ⁽¹⁾

Function

The output contact in this voltage detector will connect when controlled voltage between terminals B1-B2 exceeds a certain adjustable threshold by means of the front potentiometer and will disconnect with a voltage 10% below the setting value.

The relay requires voltages supply between A1-A2. Controlled voltage can be either direct (DC) or alternating (AC). The output contact function can be set to NO by means of an internal jumper (contact 11-14 is normally closed and opens when control power supply or removal is detected at A1-A2).

When the distance between the measurement point and the relay is greater than 1m, in order to avoid any noise problems, connection to the B1-B2 terminals should be made by using a shielded cable, with its screen joined to the B2 terminal and isolated at the other cable end or by using a twisted-pair cable.

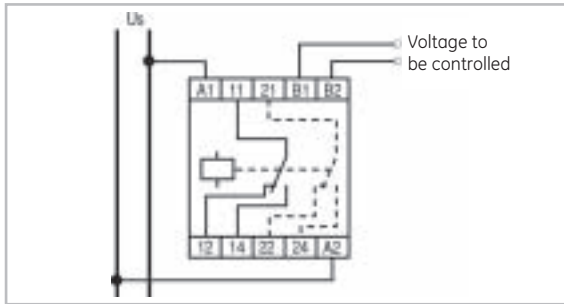

Technical characteristics

		RDT2-...	
Nr. of changeover contacts		2	
Output contacts:			
Rated insulation voltage U_i	AC (V)	400	
	DC (V)	250	
Thermal current I_{th}	(A)	6	
Utilisation AC-15			
Rated voltage U_e	(V)	120/240	
Rated current I_e	(A)	2.5/1.3	
Utilisation DC-13			
Rated voltage U_e	(V)	110/220	
Rated current I_e	(A)	0.2/0.1	
Supply voltages (Un)			
AC	(V)	220-230	
Frequency	(Hz)	50/60	
Permissible supply voltage variation (%)		+10 / -15	
Consumption (VA)		3,7	
Input circuit test voltage (between input, output circuit and earth)	(kV)	2,5	
Reset hysteresis (%)		10	
Switch ON response time (ms)		100	

Ambient conditions

Storage temperature	-10°C to +85°C
Operating temperature	-5°C to +50°C
Relative humidity	95% (without condensation)
Altitude	2.000 m
Degree of protection	IP40; terminals IP20
Operating positions	Any

Conformity to standards

VDE 0106	IEC/EN 60947-5-1
EN 50001	UNE 20-119
EN 50005	CE
EN 50011	
DIN 46199	

RDIT2 Current detector relay ⁽²⁾ with delay (0.5-15 seconds)

Function

This relay is similar to the RDI except that it will connect with a certain adjustable delay of **0.5 to 15 secs**. If current falls below threshold before timeout, relay will reset immediately to recount delay from zero. For higher currents, current transformers or shunts of suitable ratios can be used. The relay requires voltages supply between A1-A2. Controlled voltage can be either direct (DC) or alternating (AC). The output contact function can be set to NO (the 15-18 contact closes when the delay time has elapsed) or to NC (the 15-18 contact is normally closed and opens when the delay time has elapsed or when the control power supply is removed from **A1-A2**) by means of an internal jumper. The **0.2 V** version has been designed to be used with an external shunt and if the distance between the shunt and the relay is greater than 1 m, a connection to the **B1-B2** terminals should be made by using a shielded cable, with its screen joined to the **B2** terminal and isolated on the shunt side or by using a twisted-pair cable.

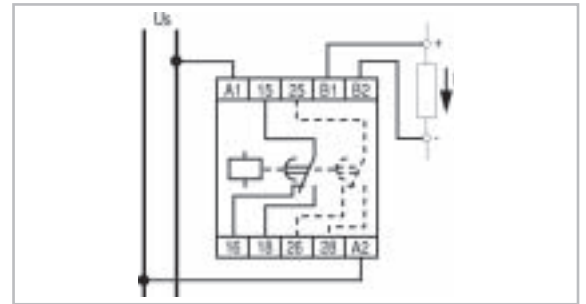

Technical characteristics

		RDIT2-...	
Nr. of changeover contacts		2	
Output contacts:			
Rated insulation voltage U_i	AC (V)	400	
	DC (V)	250	
Thermal current I_{th}	(A)	6	
Utilisation AC-15			
Rated voltage U_e	(V)	120/240	
Rated current I_e	(A)	2.5/1.3	
Utilisation DC-13			
Rated voltage U_e	(V)	110/220	
Rated current I_e	(A)	0.2/0.1	
Supply voltages (Un)			
AC (with transformer)	(V)	220-230	
Frequency	(Hz)	50/60	
Permissible supply voltage variation (%)		+10 / -15	
Repeat accuracy with 0.8 -1.1 Un (%)		2	
Consumption (VA)		3	
Input circuit test voltage (between input, output circuit and earth)	(kV)	4	
Switch OFF response time (s)		0.5 to 15	
Reset time between 2 cycles ⁽³⁾ (ms)		100	

(1) Remark

The relay has a green LED which lights up when the supply is between A1 and A2, and a red LED when the contact is made (11-14).

(2) Remark

The relay has a yellow LED which lights up when the supply is between A1 and A2, and a red LED when the contact is made **15-18**.

(3) Reset time: Time that must go by from the relay ends an operation until it is able to initiate the next one without error.

RS01N Thermistor relay

Function

This thermal probe relay is sensitive to resistance of several thermal probes (thermistors, PTC) connected to **P1** and **P2** and detect overheating in motor windings transformers, etc. where these PTC are connected.

The relays disconnects when probe resistance exceeds 2500 ohms and cannot reset until resistance is lower than 1500 ohms. Control voltage should be applied to **A1** and **A2**, the absence of this will cause relay to trip and prevent any possibility remaining without protection. In this case resetting is automatic, but if the relay trips through probe heating, resetting may be automatic, hand or remote (distance NC contact).

RS01N detect those cases of probe cables short-circuited (resistance lower than 20 Ohms) or probe cables cut (resistance higher than 2.5k Ohms). The resistance at 25 °C of the probe circuit must be within 40 to 600 ohms range.

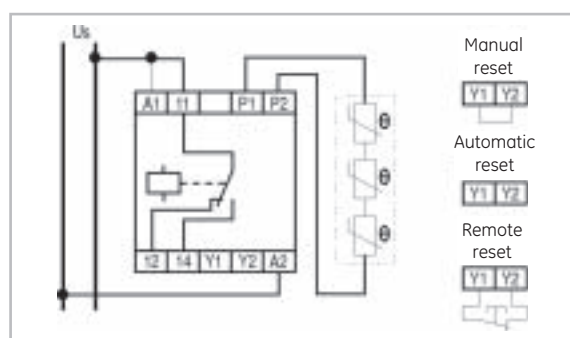

Technical characteristics

		RS01N	
Nr. of changeover contacts		1	
Output contacts:			
Rated insulation voltage U_i	AC (V)	400	
	DC (V)	250	
Thermal current I_{th}	(A)	6	
Utilisation AC-15			
Rated voltage U_e	(V)	120/240	
Rated current I_e	(A)	2.5/1.3	
Utilisation DC-13			
Rated voltage U_e	(V)	110/220	
Rated current I_e	(A)	0.2/0.1	
Supply voltages (Un)			
AC (with transformer)	(V)	220-230,125,110	
Frequency	(Hz)	50/60	
Permissible supply voltage variation (%)		+10 / -15	
Repeat accuracy with 0.85-1.1 Un (%)		2	
Consumption	(VA)	3	
Input circuit test voltage	(kV)	4	
(between input, output circuit and earth)			
Switch OFF response time	(s)	100	
Hysteresis	(kOhms)	1	
Probe resistance min. (at 25°C) (Ohms)		40	
Probe resistancemax. (at 25°C) (Ohms)		600	
Max. voltage in terminals P1-P2 (R=2.5kV/V)		< 1,6	

Ambient conditions

Storage temperature	-10°C to +85°C
Operating temperature	-5°C to +50°C
Relative humidity	95% (without condensation)
Altitude	2.000 m
Degree of protection	IP40; terminals IP20
Operating positions	Any

Conformity to standards

VDE 0106	IEC/EN 60947-5-1
EN 50001	IEC 34-11-2 (RS01N)
EN 50005	UNE 20-119
EN 50011	CE
DIN VDE 0660-303 (RS01N)	
DIN 46199 (RSR)	

Remark

The relay has one LED that lights when the output contact is made.



RCF 1 Frequency control relay

Function

This frequency control relay is sensitive to frequency of the signal applied to terminals **B1** and **B2** and output contact connects when frequency fails below a threshold adjustable by the front potentiometer. Supply voltage should also be applied to relay between terminals **A1** and **A2** to produce connection. Possibility of three settings ranges (by cross-connection): 5-15Hz, 15-45Hz, 45-135Hz.

Switching is independent of input signal level at **B1-B2**, within a wide range of values, and response is not changed by the input signal wave form (sinusoidal, square, triangular, etc).

Relay is suitable for suppression of rotor resistance in slipping asynchronous motors starters, speed reversal detector in motor wound motors and frequency control in generating sets.

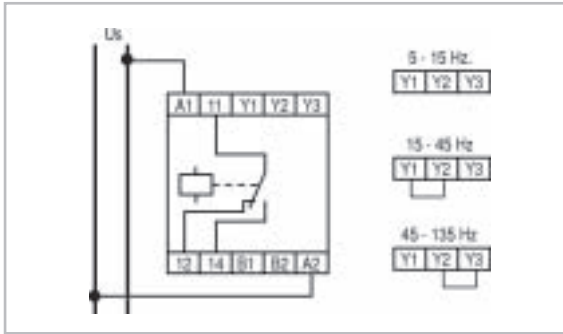

Technical characteristics

		RCF-1
Nr. of changeover contacts		1
Output contacts:		
Rated insulation voltage U_i	AC (V)	400
	DC (V)	250
Thermal current I_{th}	(A)	6
Utilisation AC-15		
Rated voltage U_e	(V)	120/240
Rated current I_e	(A)	2.5/1.3
Utilisation DC-13		
Rated voltage U_e	(V)	110/220
Rated current I_e	(A)	0.2/0.1
Supply voltages (Un)		
AC (with transformer)	(V)	380-400,220,230,110
Frequency	(Hz)	50/60
Permissible supply voltage variation(%)		+10 / -15
Voltage between B1-B2 terminals(V c.a.)		15 to 500
Repeat accuracy with 0.85-1.1 Un (%)		2
Consumption	(VA)	3
Input circuit test voltage (between input, output circuit and earth)	(kV)	4
Switch ON response time	(ms)	100
Switch OFF response time	(ms)	800
Reset hysteresis	(Hz)	1.5 approx.

Ambient conditions

Storage temperature	-10°C to +85°C
Operating temperature	-5°C to +50°C
Relative humidity	95% (without condensation)
Altitude	2.000 m
Degree of protection	IP40; terminals IP20
Operating positions	Any

Conformity to standards

VDE 0106	EN 50042 (MRI)
VDE 0110 (MRI)	DIN 46199 (RCF)
EN 50001 (RCF)	IEC/EN 60947-5-1
EN 50002 (MRI)	UNE 20-119 (RCF)
EN 50005	UL 94 (MRI)
EN 50011	UL 508 (MRI)
CE	

Remark

The relay has one LED that lights when the output contact is closed.

Dimensional drawings

Series NMV

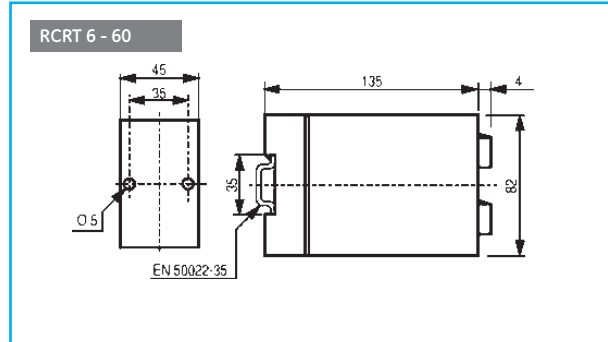
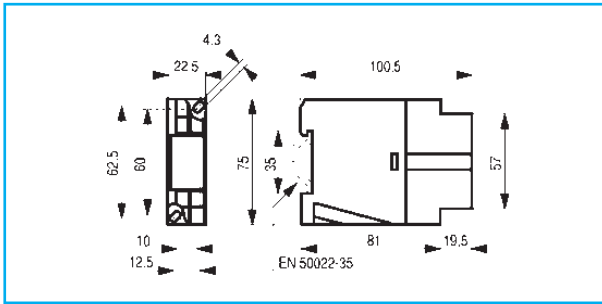

Series D

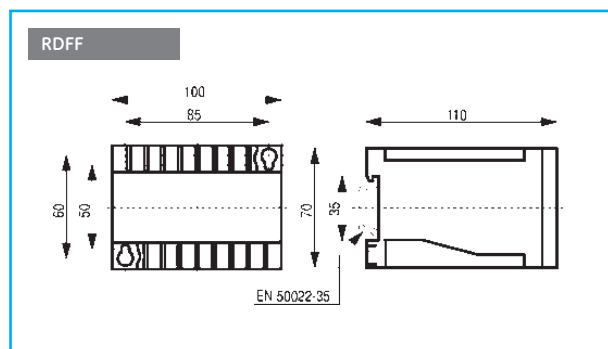
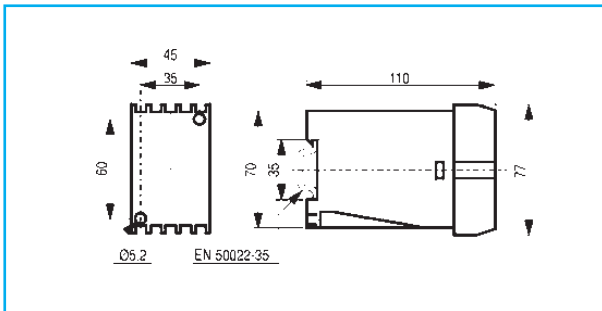

RET, RTC, RTCI, RRD, RTD, RIC, RCR, DINIL-02, DINIL-03, RTMM, RDI, RDIA RSR, RCF RS01N	A 4 8
---	-------------

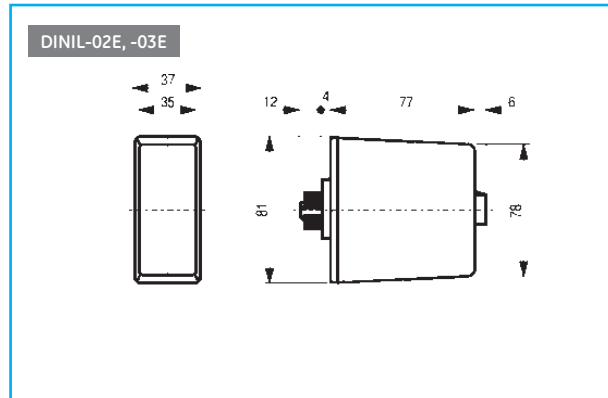

RDMT, RPDF, RMM, RDT, RDTA, RDIT, RDITA RDH, RDHT, RDHA	A 4 12
---	--------------

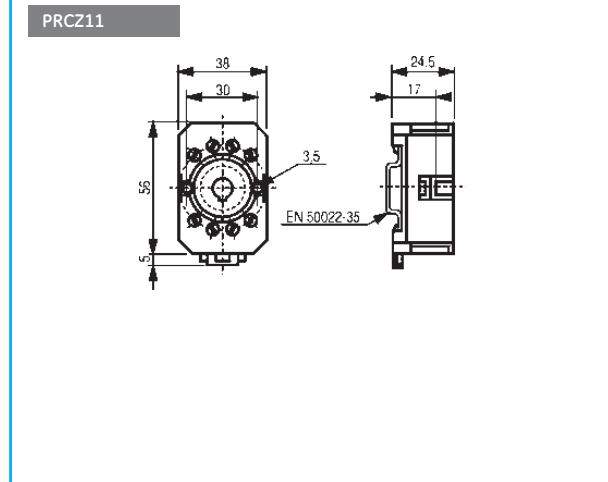

A

B

C

D

E

F

G

H

I

X



A

B

C

D

E

F

G

H

I

X

Differential transformers

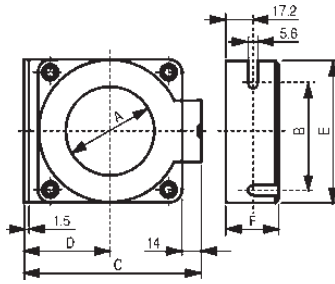

TYPE	A	B	C	D	E	F
WKA-35	35	75	99	42	92	33.5
WKA-70	70	98	132	60.5	115	33.5
WKA-105	105	141	175	82	158	33.5
WKA-140	140	183	218	103.5	200	33.5
WKA-210	210	270	309	150	290	43
WKAT-35	35	75	99	42	92	33.5
WKAT-70	70	98	132	60.5	115	33.5
WKAT-105	105	141	175	82	158	33.5
WKAT-140	140	183	218	103.5	200	33.5
WKAT-210	210	270	309	150	290	43

Remote potentiometer

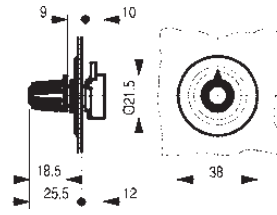

GE Consumer & Industrial Power Protection

Power Protection (formerly GE Power Controls), a division of GE Consumer & Industrial, is a first class European supplier of low-voltage products including wiring devices, residential and industrial electrical distribution components, automation products, enclosures and switchboards. Demand for the company's products comes from, wholesalers, installers, panel-board builders, contractors, OEMs and utilities worldwide.



www.ge.com/ex/powerprotection
www.ge.com/eu/powerprotection

GE CONSUMER & INDUSTRIAL
POWER PROTECTION
Nieuwevaart 51
B-9000 Gent - Belgium
Tel. +32/9 265 21 11
Fax +32/9 265 28 00
E-mail: gepcbel@gepc.ge.com

GE POWER CONTROLS Ltd
129-135 Camp Road
St Albans
Herts AL1 5HL
United Kingdom
Customer Service
Tel. 0800 587 1251
Fax 0800 587 1239
gepcuk@gepc.ge.com



GE imagination at work