

GENERAL TOLERANCE

DIM. RANGE	0.5 ~ 3	> 3 ~ 6	> 6 ~ 30	> 30 ~ 120	> 120 ~ 400
TOLERANCE	±0.1	±0.1	±0.2	±0.3	±0.5

CUSTOMER DRAWING



REV	DESCRIPTION	DATE
A	PRELIMINARY VERSION	2015-08-26
D	ADD KEYWAY TYPE	2016-03-08
E	ADD CODE NUMBER	2016-06-01

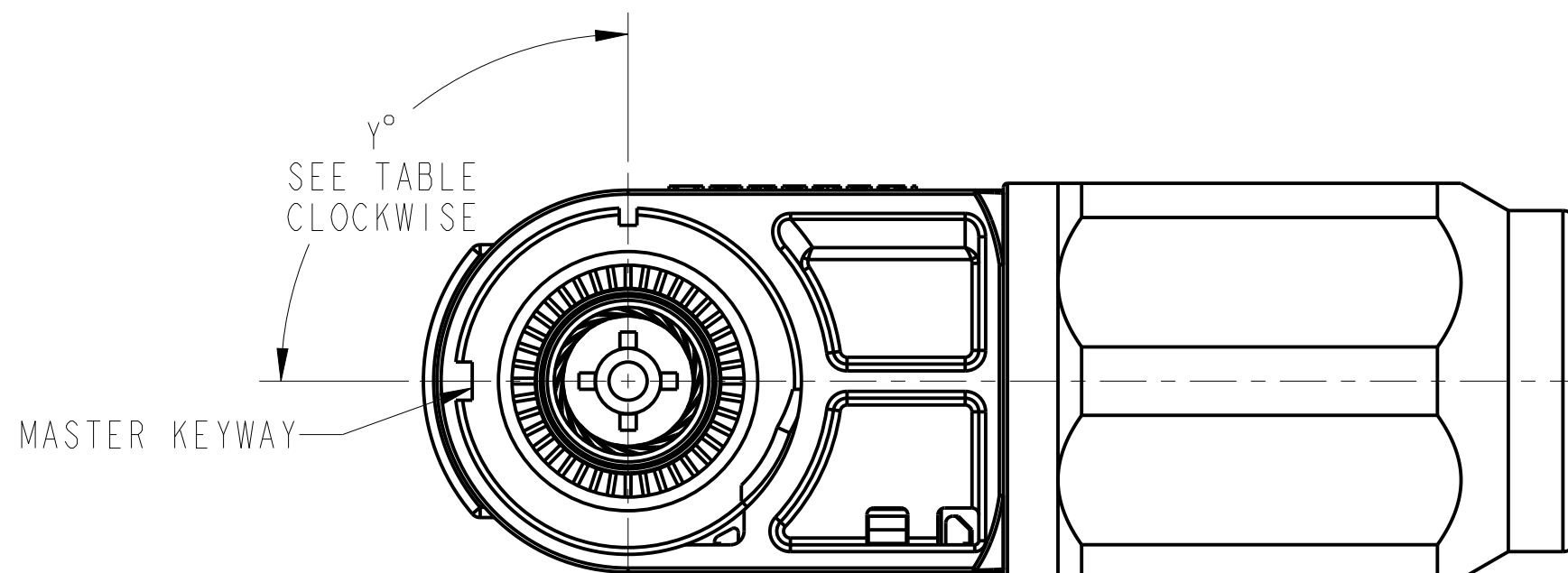
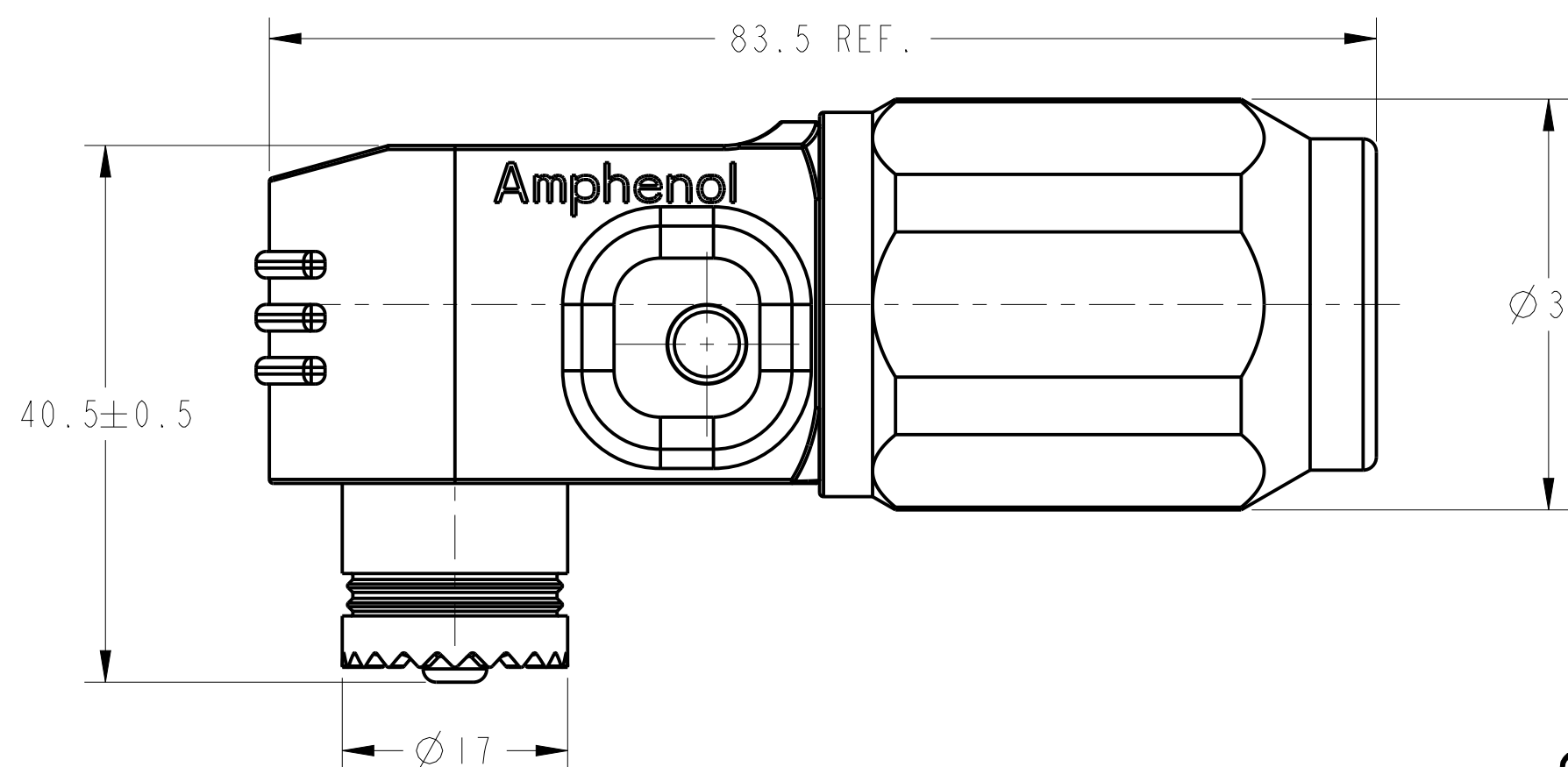
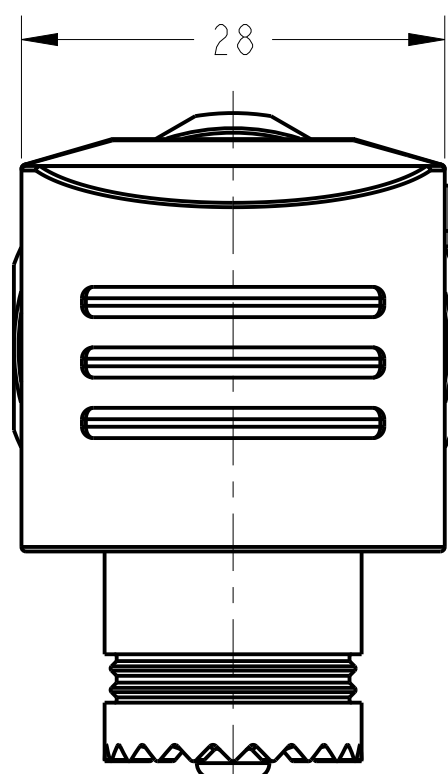

MFG PART NUMBER: C10-730190-() () () ()

BASE NUMBER
COLOR, SEE TABLE
WIRE RANGE, SEE TABLE
SEALING, SEE TABLE
KEYWAY, SEE TABLE

CODE NUMBER REFERENCE: SLPPC () B () () ()

BASE NUMBER
WIRE RANGE, SEE TABLE
WITH BACKSHELL
SEALING, SEE TABLE
COLOR, SEE TABLE
KEYWAY, SEE TABLE

SPECIFICATIONS

CURRENT RATING	300 Amps MAX
OPERATING VOLTAGE	1000V DC
OPERATING TEMPERATURE	-40°C-105°C
CONTACT RESISTANCE	0.5mΩ
PROTECTION CLASS	IP67 (MATED)

ITEM	DESCRIPTION	CODE NUMBER	MFG NUMBER
COLOR	ORANGE	O	0
	BLACK	B	1
	RED	R	2
WIRE RANGE	50MM^2	50	5
	70MM^2	70	7
	85MM^2	85	8
SEALING	IP67(MATED)	S	0
	NO SEALING	N	1
KEYWAY	90°	0	0
	180°	1	1
	60°	2	2
	120°	3	3
	150°	4	4

3. 50mm^2 AND 70mm^2 WIRE CRIMP PLUG USE THE SAME CRIMP DIE AS 85mm^2, SUPPLIED WITH A PRE-ASSEMBLED CRIMP REDUCER.

2. IF CHOOSE NO SEALING TYPE, WILL BE NO O-RINGS AND GROMMET.

1. THE REFERENCED PRODUCT IS IN COMPLIANCE WITH THE MAXIMUM CONCENTRATION VALUES (MCVS) AS SET BY RoHS 2.0 DIRECTIVE 2011/65/EU AND ANNEX II AMENDMENT DIRECTIVE (EU)2015/863.

NOTES:

THIS DOCUMENT CONTAINS PROPRIETARY INFORMATION AND SUCH INFORMATION MAY NOT BE DISCLOSED TO OTHERS FOR ANY PURPOSE OR USED FOR MANUFACTURING PURPOSES WITHOUT WRITTEN PERMISSION FROM THE AMPHENOL CORP.

N/A	PRO/ENGINEER INFORMATION
NEXT ASSEMBLY	10-730190-000.ASSEM
METRIC DOCUMENT	Drawing Name: 10-730190.CUS

UNLESS OTHERWISE SPECIFIED	SPECIFICATIONS	POS	QTY	PART NUMBER	DESCRIPTION	NOTE
LINEAR DIMENSIONS ARE IN: MILLIMETERS	MATERIAL SPEC. N/A	PARTS LIST				
TOLERANCES: ANGLES= ±2°	PROCESS SPEC. N/A	APPROVALS				
DEFAULT LINEAR TOLERANCES SEE TABLE		DATE: Aug-26-15				
DIM. & TOL. PER ASME Y14.5M-1994;		AMPHENOL INDUSTRIAL OPERATIONS				
DRM PER MIL-DTL-31000;		Amphenol Technology(Zhuhai)Co.,Ltd				
OTHER AMPHENOL STANDARDS: 9-9318		No.63, Xingnan Road, Sanzao Town, Jinwan, Zhuhai, PRC				
LEGENDS: △=FLAG NOTE CALL OUT REFERENCE ONLY		10.3MM SURLOK PLUS PLUG, RIGHT ANGLE				
		SIZE C	CAGE CODE 77820	DOCUMENT NO. 10-730190-()	REV. E	
		SCALE: 1.0	REF.	SHEET 1 OF 1		

10-730190-() SHEET 1 OF 1 REV. E

C

B

A

10-730190-() SHEET 1 OF 1 REV. E

10-730190-()

A