

Features

Relay for +105 °C ambient use
PCB mount - direct for coil and contact terminals
- 45.31, 1 Pole normally open
(≥ 3 mm contact gap)

Relays for +125 °C ambient use
PCB mount - Faston 250 contact connections
- 45.71, 1 Pole normally open or normally closed
- 45.91, 1 Pole normally open
(≥ 3 mm contact gap)

- Contact gap ≥ 3 mm according to EN 60730-1 (45.31 and 45.91 type)
- Sensitive DC coil - 360 mW
- Cadmium Free option available
- Reinforced insulation between coil and contacts according to EN 60335-1 (VDE 0700), with safe separation and 8 mm clearance and creepage distance
- 6 kV (1.2/50 μs) isolation, coil-contacts
- Flux proof: RT II standard, (RT III option)

For outline drawing see page 3

FOR UL RATINGS SEE:
"General technical information" page V

NEW 45.31



- 1 NO (SPST-NO), ≥ 3 mm gap
- Max ambient temperature +105°C
- PCB mounting

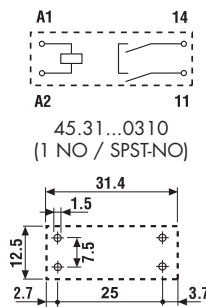

Copper side view

45.71



- 1 NO or 1 NC (SPST-NO or SPST-NC)
- Max ambient temperature +125°C
- PCB mounting + Faston 250

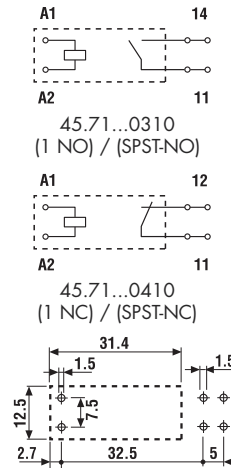

Copper side view

45.91



- 1 NO (SPST-NO), ≥ 3 mm gap
- Max ambient temperature +125°C
- PCB mounting + Faston 250

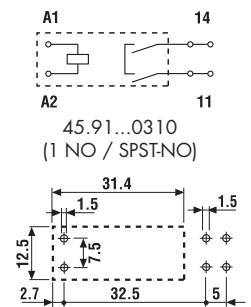

Copper side view

Contact specification				
Contact configuration		1NO (SPST-NO) ≥ 3 mm gap	1NO or 1NC (SPST-NO or SPST-NC)	1NO (SPST-NO) ≥ 3 mm gap
Rated current/Maximum peak current	A	16/30	16/30	16/30
Rated voltage/Maximum switching voltage V AC		250/400	250/400	250/400
Rated load AC1	VA	4,000	4,000	4,000
Rated load AC15 (230 V AC)	VA	750	750	750
Single phase motor rating (230 V AC)	kW	0.55	0.55	0.55
Breaking capacity DC1: 30/110/220 V	A	16/4/1	16/0.3/0.13	16/4/1
Minimum switching load	mW (V/mA)	500 (10/5)	500 (10/5)	500 (10/5)
Standard contact material		AgNi	AgCdO	AgNi
Coil specification				
Nominal voltage (U _N)	V AC (50/60 Hz)	—	—	—
	V DC	6 - 12 - 24 - 48 - 60	6 - 12 - 24 - 48 - 60	6 - 12 - 24 - 48 - 60
Rated power AC/DC	VA (50 Hz)/W	—/0.36	—/0.36	—/0.36
Operating range	AC	—	—	—
	DC	(0.7...1.2)U _N	(0.7...1.2)U _N	(0.7...1.2)U _N
Holding voltage	AC/DC	—/0.4 U _N	—/0.4 U _N	—/0.4 U _N
Must drop-out voltage	AC/DC	—/0.1 U _N	—/0.1 U _N	—/0.1 U _N
Technical data				
Mechanical life AC/DC	cycles	—/10 · 10 ⁶	—/10 · 10 ⁶	—/10 · 10 ⁶
Electrical life at rated load AC1	cycles	30 · 10 ³	100 · 10 ³	30 · 10 ³
Operate/release time	ms	12/2	10/2	12/2
Insulation between coil and contacts (1.2/50 μs)	kV	6 (8 mm)	6 (8 mm)	6 (8 mm)
Dielectric strength between open contacts	V AC	2,500	1,000	2,500
Ambient temperature range	°C	−40...+105	−40...+125	−40...+125
Environmental protection		RT II	RT II	RT II
Approvals (according to type)				

Ordering information

Example: 45 series for PCB relay + Faston 250, 1 NO (SPST-NO), 12 V DC coil.

A

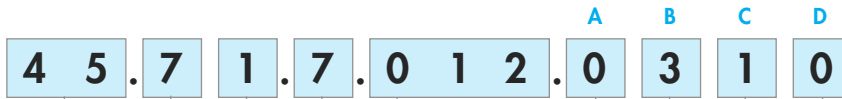

- Series** 4 5 7
- Type** 3 = PCB mount, ≥ 3 mm contact gap
7 = PCB + Faston 250 mount
9 = PCB + Faston 250 mount, ≥ 3 mm contact gap
- No. of poles** 1 = 1 pole, 16 A
- Coil version** 7 = Sensitive DC
- Coil voltage** See coil specifications
- A: Contact material**
0 = Standard AgCdO for 45.71, Standard AgNi for 45.31 and 45.91
1 = AgNi
2 = AgCdO
- B: Contact circuit**
3 = NO (SPST)
4 = NC (SPST) 45.71 only
- C: Options**
1 = None
- D: Special versions**
0 = Flux proof (RT II)
1 = Wash tight (RT III) 45.71 and 45.91 only

Selecting features and options: only combinations in the same row are possible.

Type	Coil version	A	B	C	D
45.31	sensitive DC	0 - 2	3	1	0
45.71	sensitive DC	0 - 1	3 - 4	1	0 - 1
45.91	sensitive DC	0 - 2	3	1	0 - 1

Technical data

Insulation according to EN 61810-1		45.71		45.31 / 45.91	
Nominal voltage of supply system	V AC	230/400		230/400	
Rated insulation voltage	V AC	250	400	250	400
Pollution degree		3	2	3	2
Insulation between coil and contact set					
Type of insulation		Reinforced (8 mm)		Reinforced (8 mm)	
Overvoltage category		III		III	
Rated impulse voltage	kV (1.2/50 µs)	6		6	
Dielectric strength	V AC	4,000		4,000	
Insulation between open contacts					
Type of disconnection		Micro-disconnection		Full-disconnection	
Overvoltage category		—		III	
Rated impulse voltage	kV (1.2/50 µs)	—		4	
Dielectric strength	V AC/kV (1.2/50 µs)	1,000/1.5		2,500/4	
Conducted disturbance immunity					
Burst (5...50)ns, 5 kHz, on A1 - A2		EN 61000-4-4		level 4 (4 kV)	
Surge (1.2/50 µs) on A1 - A2 (differential mode)		EN 61000-4-5		level 3 (2 kV)	
Other data		45.71		45.31 / 45.91	
Bounce time: NO/NC	ms	3/3		2/—	
Vibration resistance (10...150)Hz: NO/NC	g	20/10		20/—	
Shock resistance	g	20			
Power lost to the environment	without contact current	W	0.4		
	with rated current	W	1.8		
Recommended distance between relays mounted on PCB	mm	≥ 5			

Contact specification

F 45 - Electrical life (AC) v contact current
Type 45.71

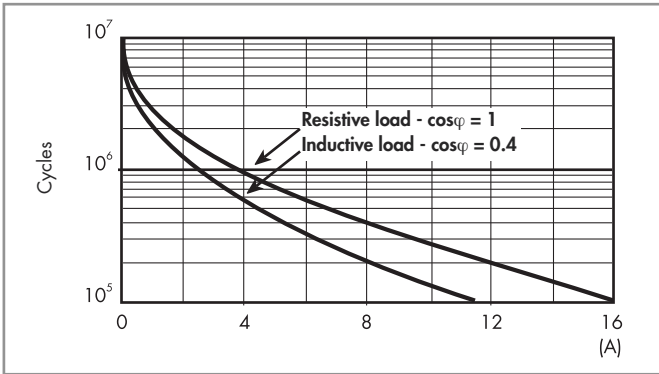

F 45 - Electrical life (AC) v contact current
Type 45.31 / 45.91

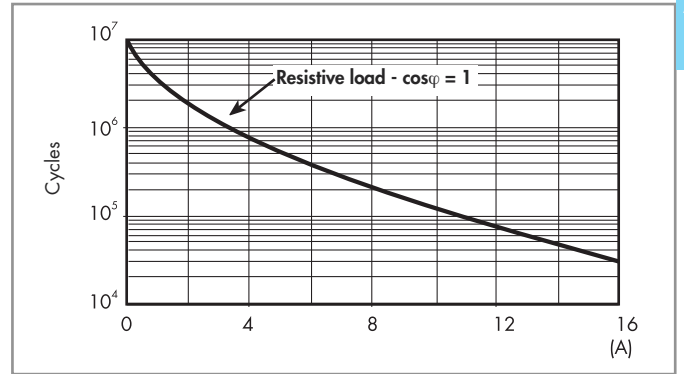

H 45 - Maximum DC1 breaking capacity

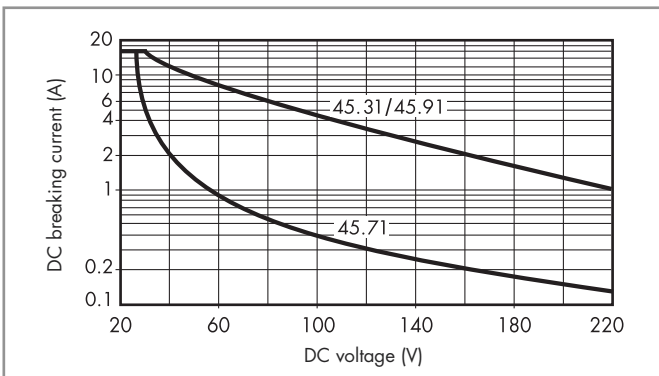

- When switching a resistive load (DC1) having voltage and current values under the curve, an electrical life of $\geq 100 \cdot 10^3$ cycles (45.71) and $\geq 30 \cdot 10^3$ cycles (45.31, 45.91) can be expected.
- In the case of DC13 loads, the connection of a diode in parallel with the load will permit a similar electrical life as for a DC1 load.
Note: the release time for the load will be increased.

Coil specifications

DC coil data - 0.36 W sensitive

Nominal voltage U_N V	Coil code	Operating range		Resistance R Ω	Rated coil consumption I at U_N mA
		U_{min} V	U_{max} V		
6	7.006	4.2	7.2	100	60
12	7.012	8.4	14.4	400	30
24	7.024	16.8	28.8	1,600	15
48	7.048	33.6	57.6	6,400	7.5
60	7.060	42	72	10,000	6

R 45 - DC coil operating range v ambient temperature

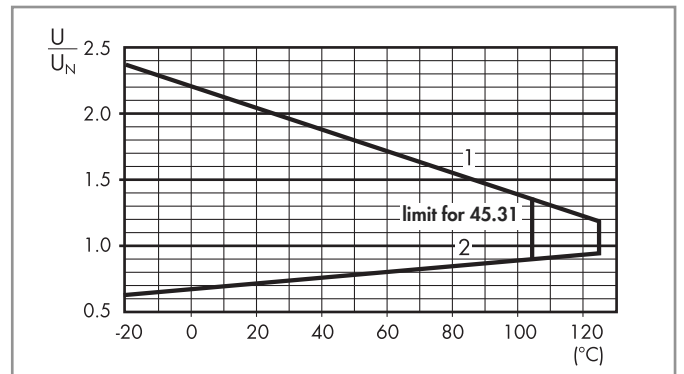

- 1 - Max. permitted coil voltage.
- 2 - Min. pick-up voltage with coil at ambient temperature.

Outline drawings

Type 45.31

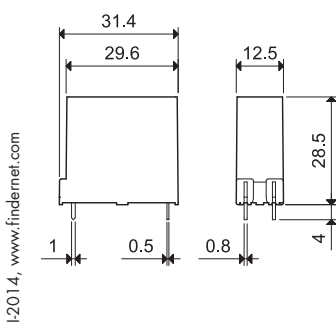

Type 45.71 / 91

