



## Properties

- Maintenance-free operation
- High tolerable dynamic loads
- High tolerable transverse forces and bending moments
- Integrated signal conditioning

## Performance

- Bi-directional measurement range from 0 to 500 Nm
- Accuracy class<sup>1)</sup> 1
- Torque measurements up to 5000 rpm
- Analog output signal

### 1. Short description

The series 2000 allows an easy and cheap torque measurement for test benches and production lines. With this torque sensor the effective torque on the gauge bar can be measured bi-directionally in real time both at rest and in rotation.

The sensor is delivered as a complete unit with corresponding connecting cable and key stones. The torque sensor is particularly characterized by its low price and high robustness.

### 2. Model Series 2000

Model Series 2000			Nominal-Torque	Max. load	Speed [rpm]
Round shaft (Rd)	Square shaft (Sq)	Unit	bidirectional (+/-)	bidirectional (+/-)	Rd/Sq
Ø 9 mm	¼ Inch	[Nm]	2.5	5.0	5000/1000
		[ft-lb]	1.8	3.7	
		[Nm]	5.0	10.0	5000/1000
		[ft-lb]	3.7	7.4	
		[Nm]	7.5	15.0	5000/1000
		[ft-lb]	5.5	11.1	
Ø 14 mm	¾ Inch	[Nm]	75.0	150.0	5000/1000
		[ft-lb]	55.3	110.6	
Ø 19 mm	½ Inch	[Nm]	175.0	350.0	5000/1000
		[ft-lb]	129.0	258.0	
		[Nm]	250.0	350.0	5000/1000
		[ft-lb]	184.3	258.0	
Ø 25 mm	¾ Inch	[Nm]	500.0	750.0	5000/1000
		[ft-lb]	368.6	552.9	

## 3. Technical Characteristics of the Sensor

No.	Model	Series 2000								
	Accuracy class <sup>1</sup>	1								
		Unit	Value							
1	Linearity deviation incl. hysteresis	%ME*	< ±1.0							
2	Rotational Signal Uniformity (RSU)	%ME*	< ±1.0							
3	Repeatability	%ME*	< ±0.05							
Output signal in general		Unit	Value							
4	Frequency range, -3dB point, Bessel characteristics	Hz	1000							
5	Analog signal	V	0 ... 5							
6	Signal at torque = Zero	V	≈ 2.5							
7	Signal at positive nominal torque	V	> 2.5							
8	Signal at negative nominal torque	V	< 2.5							
9	Calibration parameter	mV/Nm	See label							
10	Output resistance	Ω	50							
Effect of Temperature		Unit	Value							
11	Zero point drift over temperature	%/10K	< 1.0							
12	Signal drift over temperature within nominal temperature range <sup>2</sup>	%/10K	< 1.0							
Power supply		Unit	Value							
13	Supply voltage	VDC	9 ... 12							
14	Current consumption (max.)	mA	10							
15	Start-up peak	mA	< 40							
16	Absolute max. supply voltage	VDC	13							
General information		Unit	Value							
17	Degree of protection acc. to EN 60529	IP	50							
18	Reference temperature	°C	+15 ... +35							
19	Operational temperature range	°C	-40 ... +85							
20	Peak temperature temporary 12h	°C	-40 ... +105							
21	Storage temperature range	°C	-40 ... +85							
Nominal rated torque M (bi-directional)		Nm	2,5	5,0	7,5	17,5	75	175	250	500
22	Weight	Rd	g	386	392	400	685	856		1230
		Sq		395	401	414	652	754		878
23	Moment of inertia	Rd	g mm <sup>2</sup>	597	662	1073	4922	19126		79754
		Sq		582	648	904	3339	13294		57770

%ME: related to a full scale measurement range

- The accuracy class implies that taken separately both the linearity deviation as well as the rotational signal uniformity are either lower than or equal to the value of the accuracy class. The accuracy class is not to be identified with the classification following DIN 51309 or EA-10/14.
- The factor of transmission declines linearly up to a maximum of 0,5% / 10K with rising temperature, due to the reduction of the elasticity.

## 4. Dimensions

**2200 (TM-HR-Rd)  
Round drive**

**2100 (TM-HR-Sq)  
Square drive**

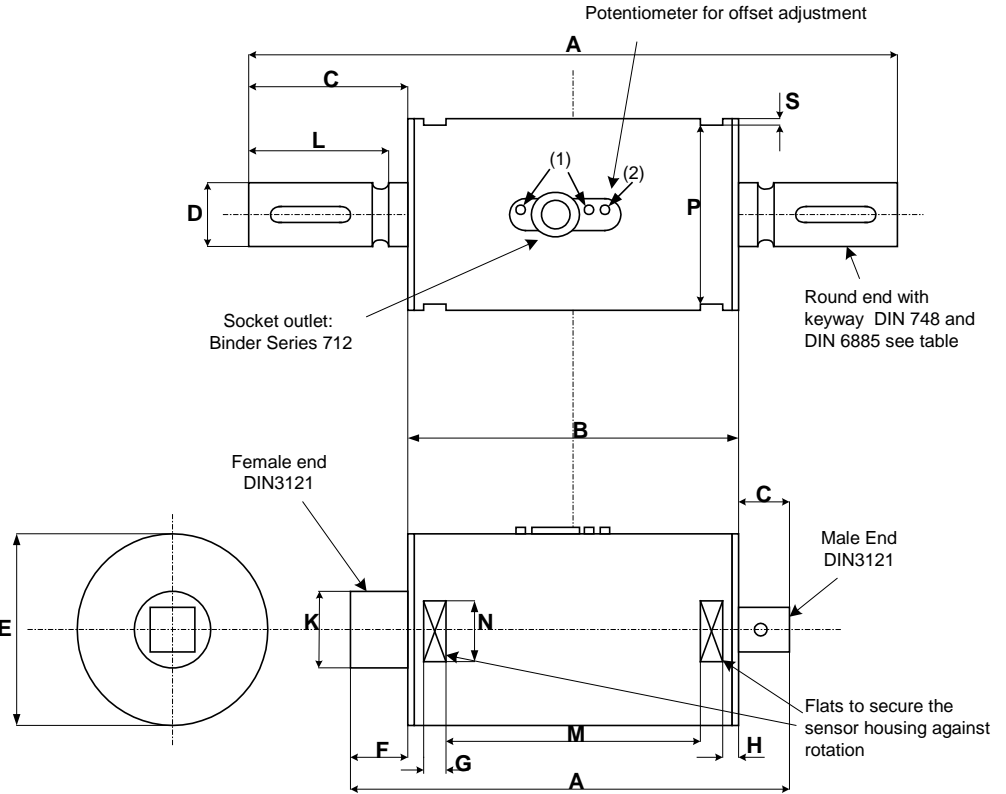

(1) Do not loosen or tighten the mounting nuts of the socket and the lock screws

Dimensions	Nominal Torque Capacity [Nm]	A	B	C	D	E	F	G	H	K	L	M	N	P	S
<b>Square drive shaft (2100)</b>															
1/4 Inch	2.5 - 5.0 - 7.5 - 17.5	95,5	70	9,5	-	40	16	8	5	12	-	43,9	15	37	1,5
3/8 Inch	75	107	70	13	-	50	24	8	5	18	-	43,9	18	47	1,5
1/2 Inch	175 - 250	123,5	70	18,5	-	50	35	8	5	24	-	43,9	18	47	1,5
3/4 Inch	500	146	87	29,6	-	60	29,6	10,5	2	33,5	-	61,4	19	57	1,5
<b>Round drive shaft (2200)</b>															
Ø 9 mm	2.5 - 5.0 - 7.5 - 17.5	125	70	27,5	9	40	-	8	5	-	23	43,9	15	37	1,5
Ø 14 mm	75	139	70	34,5	14	50	-	8	5	-	30	43,9	18	47	1,5
Ø 19 mm	175 - 250	179	70	54,5	19	50	-	8	5	-	50	43,9	18	47	1,5
Ø 25 mm	500	220	87	66,6	25	60	-	10,5	2	-	-	61,4	19	57	1,5

Round drive shaft	Dimensions Keyway [mm]			Keystones		
	Width	Depth	Length	Height	Length	Amount
Ø 9 mm	3	1,8	18,5	3	18	1
Ø 14 mm	5	3	25,5	5	25	1
Ø 19 mm	6	3,5	45,5	6	45	1
Ø 25 mm	8	4	50,5	8	50	2

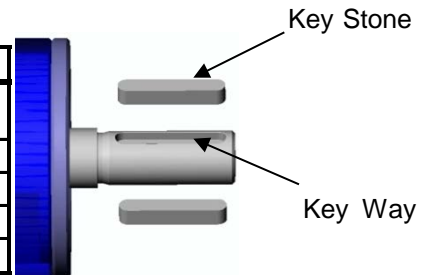

The second Key Way (only for Series 2200-500) in mirrored position (180°)

## 5. Connection Plan

Sensor pin assignment  
Presentation: top view

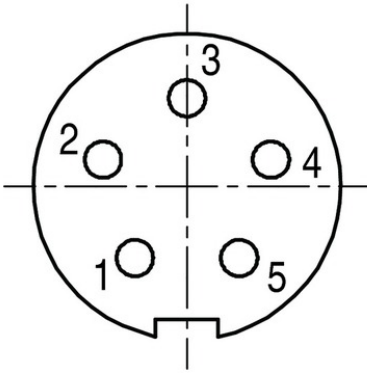

Type: Binder Series M9 Connector IP67 Order Number: 09 0416 90 05			
Pin	Color	Description	Value
1	White	Supply Voltage $V_{CC}$	9 V – 12 V
2	Brown	Signal Output analogue	
3	Black	Ground GND	
4	Blue	Not used	
5	Grey	Reference Voltage $V_{ref}$	2.5 V

The output  $V_{ref}$  is a constant 2.5 V and represents the virtual zero point for direct +/- torque measurement (See below “*Sensor cable connection*” section B).

### Sensor cable connection

- A) This circuit is recommended for **absolute** torque measurement e.g. 2.5 V equals to approx. 0 Nm.

**Grey and blue wires are not in use.**

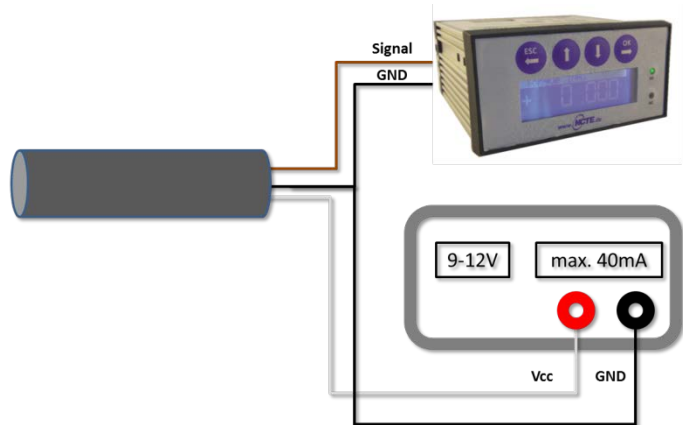

- B)  
C) This circuit is recommended for **relative** torque measurement e. g. 0 V equals to approx. 0 Nm.

**Blue wire is not in use.**

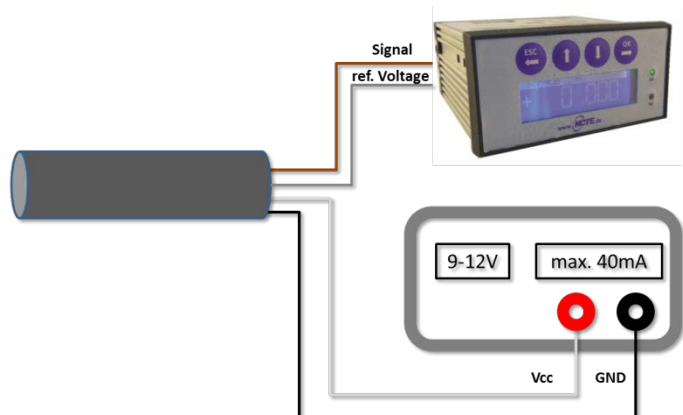

## 6. Operating Instructions

### Field of Application

The torque sensor is intended for use in an industrial environment (e. g. test bench).

### Scope of Delivery

The torque sensor set consists of the sensor itself (signal pick-up and signal processing integrated into sensor housing), one connecting cable with a soldered plug, key stones and the instruction manual.

### Installation and Removal

Make sure to install the sensor shafts exactly with the proper aligned connecting shafts. The key stone adapter / square endings of the connecting shafts are to be attached forceless to the corresponding ones of the sensor. No external axial force should be on the housing of the sensor by fixing it. The spanner flat is for the protection of the sensor from distortion. A maximum cable length of 5 m must not be exceeded. Using a cable or connector other than supplied by **NCTE**, or a similar cable that is of a different length may affect the overall performance of the sensor.

**DO NOT REMOVE THE SHAFT WITH TORQUE APPLIED TO THE SENSOR.**

### Interface Description

Mechanical connection:

The key stone adapters on both ends of the measurement shaft are intended for torque transmission.

Electrical connector:

On the sensor housing there is a 5-pin socket for the power supply and the signal output (see Chapter 6 Connection Plan).

### Operation (in regular case or in optimal case)

Optimal measurement parameters can be achieved when the sensor is applied in accordance to the specification. Use the sensor only for short periods of time at the maximum rotational speed. By compliance with the specification the sensor works generally trouble-free and maintenance-free.

### Irregular Operation, Measures against Disturbance

The presence of external electromagnetic or magnetic fields can lead to irregular measurement results. The mechanical overload on the sensor (e.g. exceeding of maximum allowed torque or severe vibrations) may cause damage to the sensor and in consequence the incorrect signal output. In such cases please do not open the sensor. Contact **NCTE** directly for assistance.

### Commissioning

After sensor installation pay attention to the followings:

- Switch on the power supply unit and check the supply voltage. Peak voltage must be avoided! Be sure to verify the power supply voltage before connecting the sensor!
- Connect the sensor to the power supply unit by using the delivered cable.
- Connect the sensor output to a high-resistance device such as an A/D converter, oscilloscope, PC measurement board. The sensor should be in mechanical unloaded state while connecting it.

### Service and Maintenance

Service Hotline:

Phone: +49 89 66 56 19 0

Fax: +49 89 66 56 19 29

### Disposal

Please return the device to **NCTE** for disposal.

## Handling and Transportation

By handling, storage and transportation keep the sensor away from magnetic or electromagnetic fields which may exceed the maximal intensity defined from EMC (see Chapter 3. Technical Characteristics of the Sensor).

## Precautions

- Do not open the sensor housing under any circumstances.
- Do not remove or loosen the locking rings on the shaft ends.
- Do not loosen or tighten the flange-mounting nut of the socket-connector and the fixing screws(1) (see Chapter 5. Dimensions).
- Use only a separate power supply for the sensor.
- Use the sensor only according to the specification (Chapter 3. Technical Characteristics of the Sensor)

## 7. Typical Sensor Output

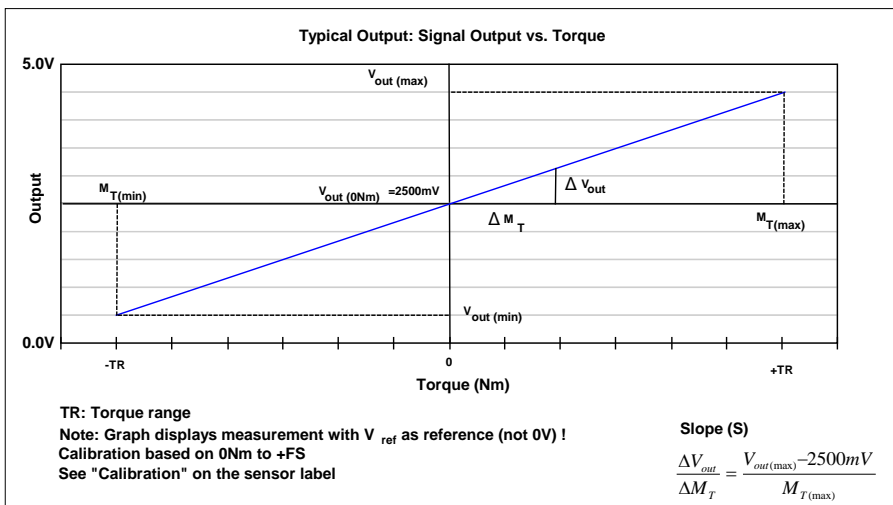

## Example of sensor label



$V_{out(max)}$  and  $V_{out(min)}$  are defined with the slope of the sensor. i.e. the output voltage could be between 0.5 V and 4.5 V. The actual signal output range depends however on the calibration value.

## 8. Order Options Series 2000

Serie 2000 Accuracy 1 % with 5 m cable		
Serie 2100 Square drive		
Serie 2200 Key stone		
<b>Option 1: Measurement range</b>		
2,5	2.5 Nm	
5	5 Nm	
7,5	7.5 Nm	
17,5	17.5 Nm	
75	75 Nm	
175	175 Nm	
250	250 Nm	
500	500 Nm	

### Read Out Unit for all NCTE Sensors



Ord.-No. 400010-ATS001

- Compact readout box with display
- 1 torque sensor input, 0-5V and 0-10V
- 1 angle encoder input, A/B
- 2x digital output
- USB interface, Windows software included
- SD card slot

## 9. Contact

NCTE AG  
Inselkammerstr. 4  
82008 Unterhaching  
Germany  
Tel.: +49 89 665619-0  
Fax: +49 89 665619-29  
Email: [sales@ncte.de](mailto:sales@ncte.de)