

Climate control – 19" fan trays

Pusher fan, 2 U, with tangential fan



01192009

- High airflow volume
- Integrated filter mat
- 2 versions:
 - LE1: 19" bolt-on dimension, fan unit is wider than 19"
 - LE2: 19" reduced width, for easy assembly



Delivery comprises (ready to connect)

Item	Qty	Description
1	1	Blower unit 2 U, with grille, PA 6.6, UL 94 V-0, front grille 2 U, PPO, UL 94 V-0; filter mat, synthetic fibre, filter class G 2
2	1	Fan
3	1	Terminal block

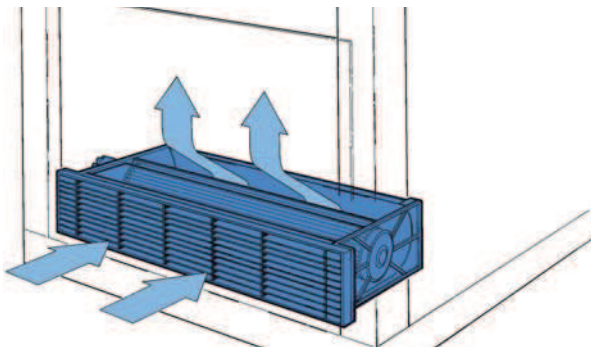

A3532

Order Information

Description	115 V _{AC}	230 V _{AC}
	Part no.	Part no.
LE1: Pusher fan 2 U, tangential blower	60713-003	60713-001
LE2: Pusher fan 2 U, tangential blower	60713-004	60713-002
Spare filter mat PU 10 pieces		20705-008

Dimensions

Voltage	115 V _{AC}		230 V _{AC}	
	Frequency in Hz	50	60	50
Airflow volume in m ³ /h	320	330	320	330
Noise level in dB(A)	59	62	59	62
Max. stat. pressure in Pa	65	70	65	70
Power consumption in W	30	40	37	46
Permissible ambient temperature in °C	-20 ... +65 °C			
Lifespan in h	30000			

Note

- 24 V_{DC} on request
- Fan dimensioning, see page 4.18



For further information www.schroff.biz/oneclick
oneClick search code = Part no.

LE 1

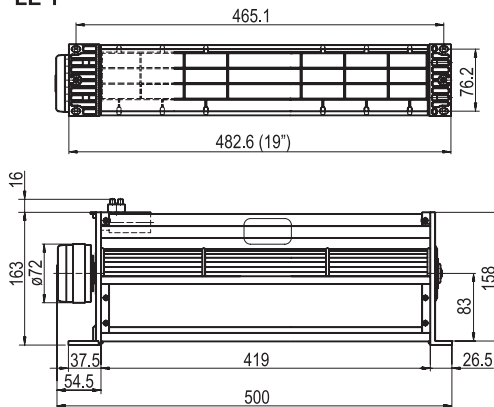

LE 2

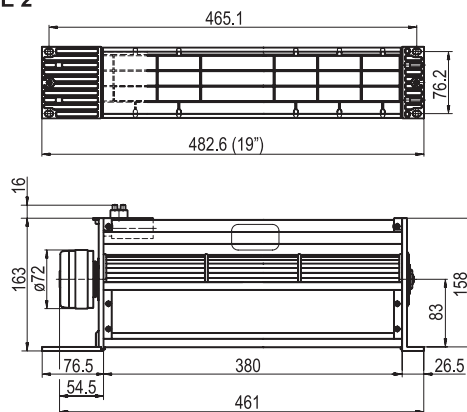

01103056



ServicePLUS see page 4.19