

Climate control – Accessories

Heater fans 475/550 W



01108030

- Heater with fan and thermostat
- Simple and fast assembly with clip-on attachment
- 3-pin terminal clamp, separate heater/fan connection
- Thermostat from 0 ... 60 °C
- Temperature limiting with PTC resistor



Delivery comprises (completely assembled)

Item	Qty	Description
1	1	Plastic housing, polycarbonate (RAL 9002, grey white), clip for 35 mm DIN rail EN 50022
2	1	Heater element, 230 V _{AC} , resistor (PTC) self-regulating
3	1	Thermostat
4	1	230 V _{AC} fan

Order Information

Description	Part no.
Heater 475 W	60715-017
Heater 550 W	60715-018
Support rail DIN rail EN 50022 (35 mm), length 215 mm, 1 piece	20715-001

Technical data

Voltage range	230 V _{AC}			
	50 Hz	60 Hz	50 Hz	60 Hz
Frequency	50 Hz	60 Hz	50 Hz	60 Hz
Heater output	475 W	550 W	550 W	650 W
Air capacity of axial fan	35 m ³ /h	39 m ³ /h	45 m ³ /h	50 m ³ /h
Current at switch-on approx.	11 A		13 A	
Weight	0.9 kg		1.1 kg	
Heater element	Resistor (PTC), self-regulating			
Connection	3-pin connecting terminal, 2.5 mm ² , separate connection heating/fan			
Thermostat	Adjustment range 0 ... 60 °C			
Control lamp of control system	Glow lamp			
Temperature control	In the event of fan failure			
Type of protection	IP 20			
Class of protection	II			
Assembly	Clip-on attachment for 35 mm DIN rail (EN 50022)			
Dimensions	Height 165 mm, width 100 mm, depth 128 mm			

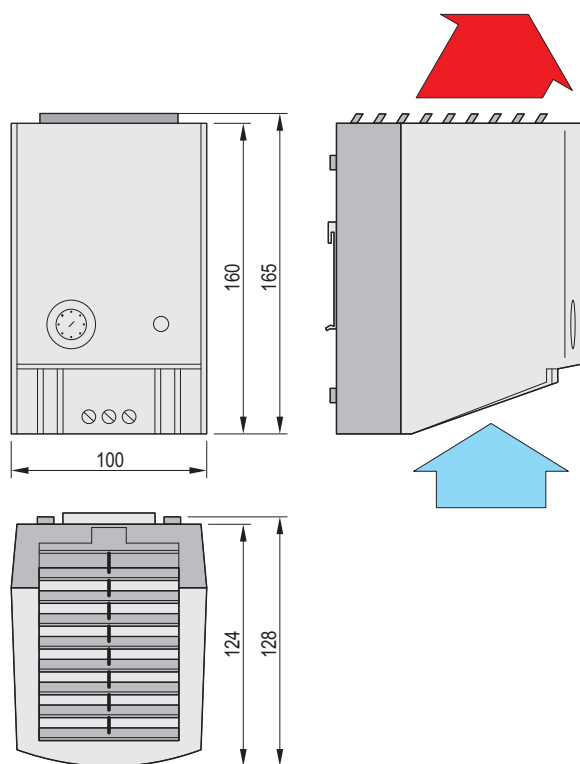

01108069

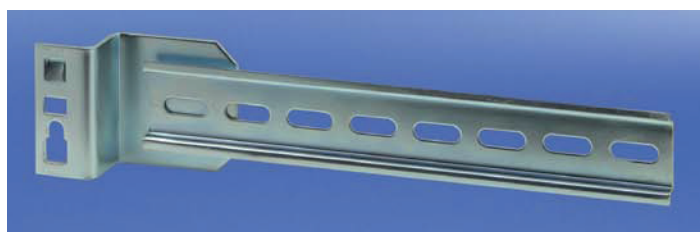

00508013

Support rail



For further information www.schroff.biz/oneclick
oneClick search code = Part no.