

HF Connectors

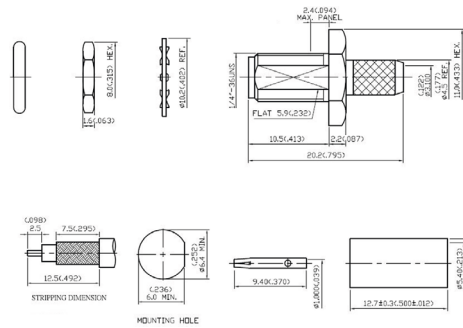

Female Connector SMA 50 Ω, straight



SPECIFICATION:

Mounting	Panel mount
Housing Material	Brass/Gold-plated
Series	SMA
Frequency	12.4 GHz
Gender	Female
Insulation material	Teflon
Impedance	50 Ω
CAT Catalogue Description	2Crimp Ferrule - Brass, Gold-plated - Gasket - Silicone, Red - Washer - Brass, Gold-plated - Nut - Brass, Gold-plated - O-Ring - Rubber, Black
Connector Design	straight
Connection, attachment	Solder
Connection, shield	Crimp 5.5 mm
Cable type	RG-58U
Contacts	Beryllium Copper/gold-plated

PRODUCT RANGE:

Art. Nr.

RND 205-00451

Cable Mounting Instructions



1. Preparation of Cable

- (1) Slide crimp ferrule onto cable
- (2) Strip cable to recommended dimensions shown in catalogue



2. Crimping Center Contact to Cable Center Conductor

- (1) Insert cable center conductor into center contact until cable dielectric rest against center contact
- (2) Crimp (or Solder) center contact to cable center conductor

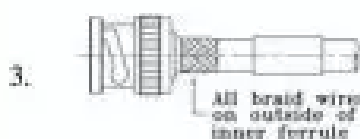

3. Inserting Cable to Connector Body

- (1) Flare slightly end of cable braid to facilitate insertion of connector body
- (2) Insert cable assembly into rear of connector body, with all braid wires on outside of inner ferrule
- (3) Push cable assembly forward until contact seat inside of insulator or inner center contact



4. Final Assembly

- (1) Slide crimp ferrule forward until flush with connector body
- (2) Hold cable firmly seated then crimp in place