

SECTION UU-UU

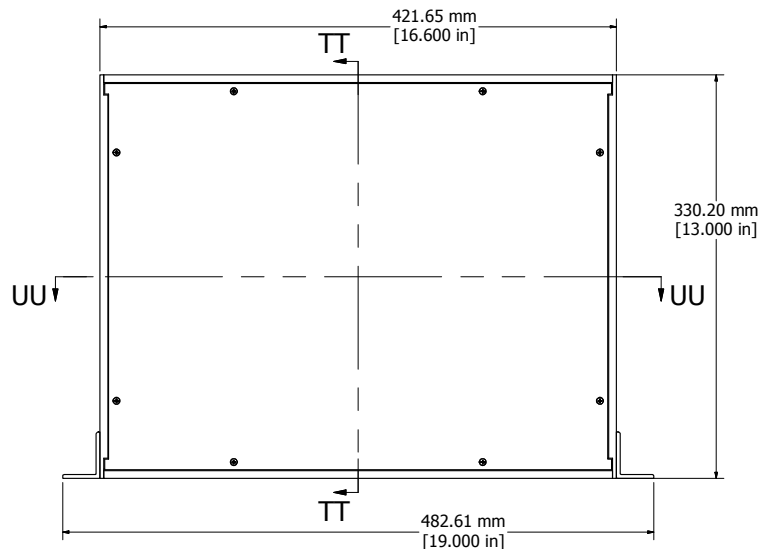

ASSEMBLY - VIEW FROM TOP

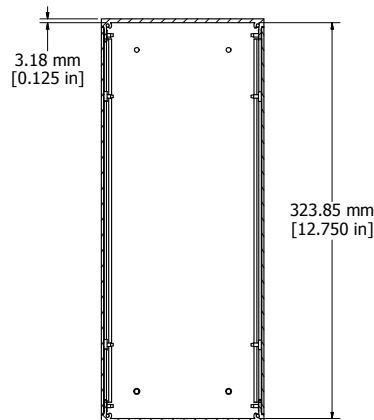

SECTION TT-TT

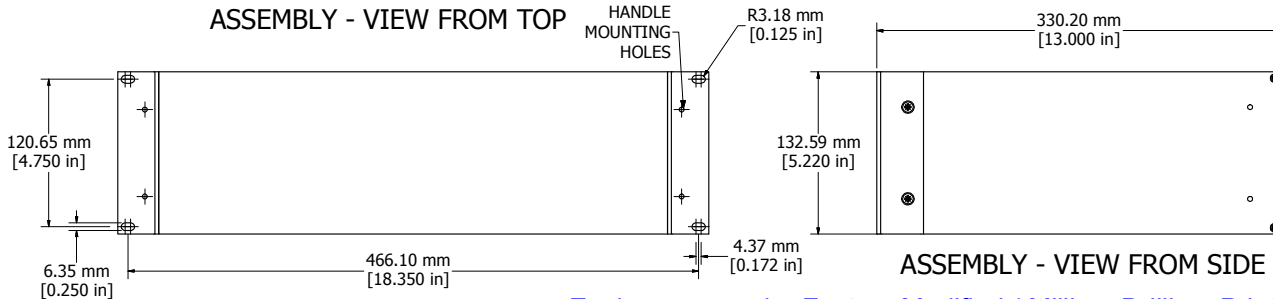

ASSEMBLY - VIEW FROM FRONT

ASSEMBLY - VIEW FROM SIDE

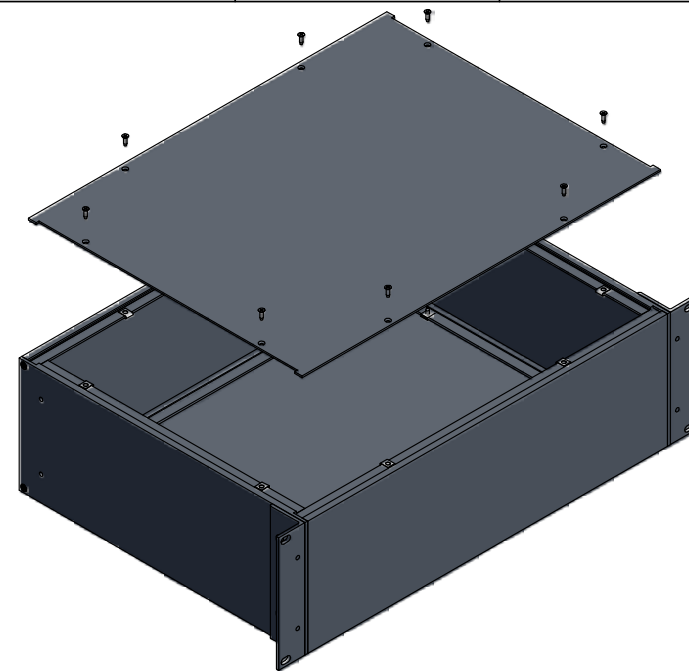

**RM3U1913SBK**

- Extruded Aluminum Frame - Type 6063
- 2 Panels - .064" Aluminum (5052-H32) Powder Coat (RAL 7032)
- 2 Mounting Brackets - .125" Aluminum
- 16 Screws - Flat Head 4-40 x 3/8"
- 8 Screws - Counter Sunk Head 6-32 x 3/8"
- 4 Screws - Counter Sunk Head 10-32 x 3/8"
- 16 Nuts - #4 Speed Nuts
- Four Self Adhesive Rubber Feet - 1421T3

**ACCESSORIES**

PULL HANDLES

1427P1BK



**HAMMOND  
MANUFACTURING™**

**RM3U1913SBK**

www.hammondmfg.com

Enclosures can be Factory Modified ( Milling, Drilling, Printing etc. )  
 Contact Factory [mjm@hammondmfg.com](mailto:mjm@hammondmfg.com) for quotes  
 Solid models of this enclosure available in STEP or IGES.