

SECTION FF-FF

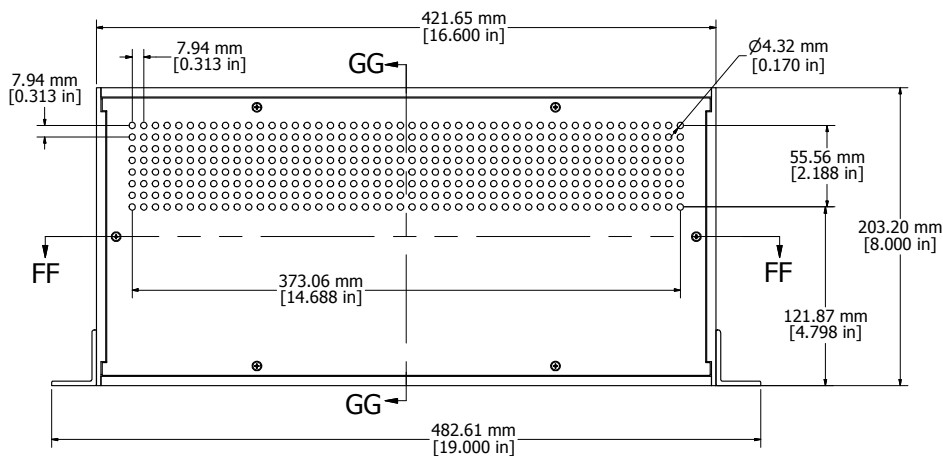

ASSEMBLY - VIEW FROM TOP

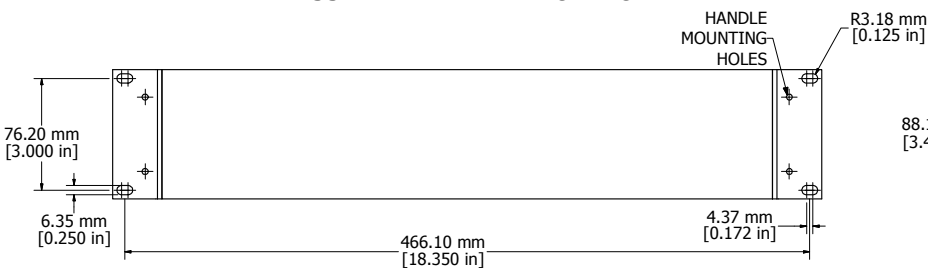

ASSEMBLY - VIEW FROM FRONT

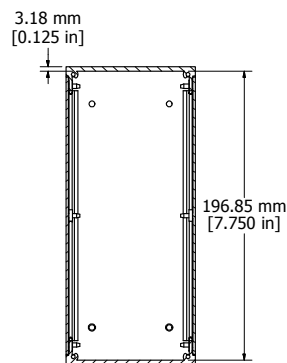

SECTION GG-GG

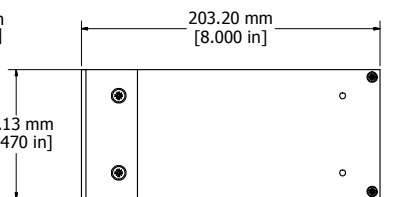

ASSEMBLY - VIEW FROM SIDE

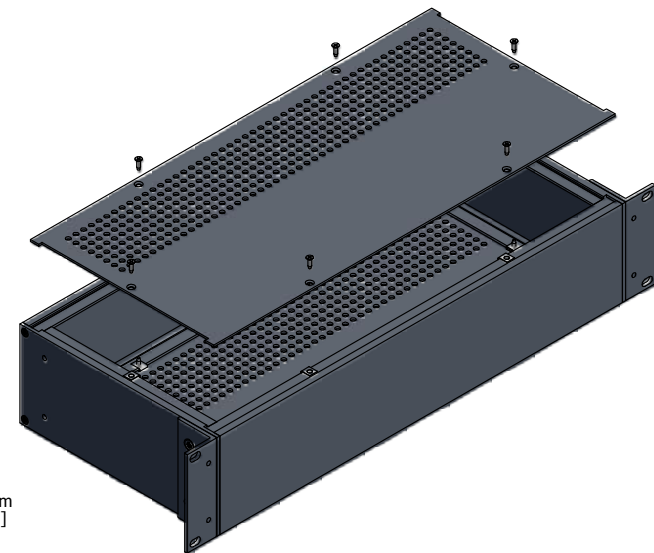

RM2U1908VBK	
Extruded Aluminum Frame - Type 6063	
2 Panels - .064" Aluminum (5052-H32) Powder Coat (RAL 7032)	
2 Mounting Brackets - .125" Aluminum	
12 Screws - Flat Head 4-40 x 3/8"	
8 Screws - Counter Sunk Head 6-32 x 3/8"	
4 Screws - Counter Sunk Head 10-32 x 3/8"	
12 Nuts - #4 Speed Nuts	
Four Self Adhesive Rubber Feet - 1421T3	
ACCESSORIES	
PULL HANDLES	1427E1BK



**HAMMOND
MANUFACTURING™**

RM2U1908VBK

www.hammondmfg.com

Enclosures can be Factory Modified (Milling, Drilling, Printing etc.)
 Contact Factory mjm@hammondmfg.com for quotes
 Solid models of this enclosure available in STEP or IGES.