

Antenna - PSI-GSM/UMTS-QB-ANT - 2313371

Please be informed that the data shown in this PDF Document is generated from our Online Catalog. Please find the complete data in the user's documentation. Our General Terms of Use for Downloads are valid (<http://phoenixcontact.com/download>)

GSM UMTS antenna, with omnidirectional characteristic, 2 m antenna cable with SMA round connector



Key Commercial Data

Packing unit	1 STK
GTIN	
GTIN	4046356411066
Custom tariff number	85177000

Technical data

Dimensions

Height	21 mm
Diameter	76 mm
Fixed cable length	2.00 m

Ambient conditions

Ambient temperature (operation)	-40 °C ... 85 °C
---------------------------------	------------------

General

With connecting cable	yes
Frequency range	850 MHz
	900 MHz
	1800 MHz
	1900 MHz
	2100 MHz
Gain	5 dBi (800/900 MHz)
	3 dBi (1800/1900 MHz)
	1 dBi (2100 MHz)
Connection method	SMA (male)

Antenna - PSI-GSM/UMTS-QB-ANT - 2313371

Technical data

General

Fixed cable length	2.00 m
Mounting type	Control cabinet

Environmental Product Compliance

China RoHS	Environmentally friendly use period: unlimited = EFUP-e
	No hazardous substances above threshold values

Drawings

Schematic diagram

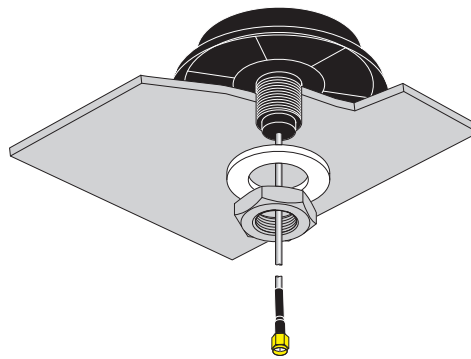

Assembly

Approvals

Approvals

Approvals

EAC

Ex Approvals

Approval details

EAC		EAC-Zulassung
-----	--	---------------
