



**MICROCHIP**

---

**PIC18(L)F2X/4XK22**  
**Data Sheet**

28/40/44-Pin, Low-Power,  
High-Performance Microcontrollers  
with XLP Technology

---

**Note the following details of the code protection feature on Microchip devices:**

- Microchip products meet the specification contained in their particular Microchip Data Sheet.
- Microchip believes that its family of products is one of the most secure families of its kind on the market today, when used in the intended manner and under normal conditions.
- There are dishonest and possibly illegal methods used to breach the code protection feature. All of these methods, to our knowledge, require using the Microchip products in a manner outside the operating specifications contained in Microchip's Data Sheets. Most likely, the person doing so is engaged in theft of intellectual property.
- Microchip is willing to work with the customer who is concerned about the integrity of their code.
- Neither Microchip nor any other semiconductor manufacturer can guarantee the security of their code. Code protection does not mean that we are guaranteeing the product as "unbreakable."

Code protection is constantly evolving. We at Microchip are committed to continuously improving the code protection features of our products. Attempts to break Microchip's code protection feature may be a violation of the Digital Millennium Copyright Act. If such acts allow unauthorized access to your software or other copyrighted work, you may have a right to sue for relief under that Act.

---

Information contained in this publication regarding device applications and the like is provided only for your convenience and may be superseded by updates. It is your responsibility to ensure that your application meets with your specifications. MICROCHIP MAKES NO REPRESENTATIONS OR WARRANTIES OF ANY KIND WHETHER EXPRESS OR IMPLIED, WRITTEN OR ORAL, STATUTORY OR OTHERWISE, RELATED TO THE INFORMATION, INCLUDING BUT NOT LIMITED TO ITS CONDITION, QUALITY, PERFORMANCE, MERCHANTABILITY OR FITNESS FOR PURPOSE. Microchip disclaims all liability arising from this information and its use. Use of Microchip devices in life support and/or safety applications is entirely at the buyer's risk, and the buyer agrees to defend, indemnify and hold harmless Microchip from any and all damages, claims, suits, or expenses resulting from such use. No licenses are conveyed, implicitly or otherwise, under any Microchip intellectual property rights.

**Trademarks**

The Microchip name and logo, the Microchip logo, dsPIC, KEELOQ, KEELOQ logo, MPLAB, PIC, PICmicro, PICSTART, PIC<sup>32</sup> logo, rfPIC and UNI/O are registered trademarks of Microchip Technology Incorporated in the U.S.A. and other countries.

FilterLab, Hampshire, HI-TECH C, Linear Active Thermistor, MXDEV, MXLAB, SEEVAL and The Embedded Control Solutions Company are registered trademarks of Microchip Technology Incorporated in the U.S.A.

Analog-for-the-Digital Age, Application Maestro, chipKIT, chipKIT logo, CodeGuard, dsPICDEM, dsPICDEM.net, dsPICworks, dsSPEAK, ECAN, ECONOMONITOR, FanSense, HI-TIDE, In-Circuit Serial Programming, ICSP, Mindi, MiWi, MPASM, MPLAB Certified logo, MPLIB, MPLINK, mTouch, Omniscient Code Generation, PICC, PICC-18, PICDEM, PICDEM.net, PICkit, PICtail, REAL ICE, rfLAB, Select Mode, Total Endurance, TSHARC, UniWinDriver, WiperLock and ZENA are trademarks of Microchip Technology Incorporated in the U.S.A. and other countries.

SQTP is a service mark of Microchip Technology Incorporated in the U.S.A.

All other trademarks mentioned herein are property of their respective companies.

© 2010-2012, Microchip Technology Incorporated, Printed in the U.S.A., All Rights Reserved.

 Printed on recycled paper.

ISBN: 9781620763131

**QUALITY MANAGEMENT SYSTEM  
CERTIFIED BY DNV  
= ISO/TS 16949 =**

*Microchip received ISO/TS-16949:2009 certification for its worldwide headquarters, design and wafer fabrication facilities in Chandler and Tempe, Arizona; Gresham, Oregon and design centers in California and India. The Company's quality system processes and procedures are for its PIC<sup>®</sup> MCUs and dsPIC<sup>®</sup> DSCs, KEELOQ<sup>®</sup> code hopping devices, Serial EEPROMs, microperipherals, nonvolatile memory and analog products. In addition, Microchip's quality system for the design and manufacture of development systems is ISO 9001:2000 certified.*

---

---

**28/40/44-Pin, Low-Power, High-Performance  
Microcontrollers with XLP Technology**

---

---

**High-Performance RISC CPU:**

- C Compiler Optimized Architecture:
  - Optional extended instruction set designed to optimize re-entrant code
- Up to 1024 Bytes Data EEPROM
- Up to 64 Kbytes Linear Program Memory Addressing
- Up to 3896 Bytes Linear Data Memory Addressing
- Up to 16 MIPS Operation
- 16-bit Wide Instructions, 8-bit Wide Data Path
- Priority Levels for Interrupts
- 31-Level, Software Accessible Hardware Stack
- 8 x 8 Single-Cycle Hardware Multiplier

**Flexible Oscillator Structure:**

- Precision 16 MHz Internal Oscillator Block:
  - Factory calibrated to  $\pm 1\%$
  - Selectable frequencies, 31 kHz to 16 MHz
  - 64 MHz performance available using PLL – no external components required
- Four Crystal modes up to 64 MHz
- Two External Clock modes up to 64 MHz
- 4X Phase Lock Loop (PLL)
- Secondary Oscillator using Timer1 @ 32 kHz
- Fail-Safe Clock Monitor:
  - Allows for safe shutdown if peripheral clock stops
  - Two-Speed Oscillator Start-up

**Analog Features:**

- Analog-to-Digital Converter (ADC) module:
  - 10-bit resolution, up to 30 external channels
  - Auto-acquisition capability
  - Conversion available during Sleep
  - Fixed Voltage Reference (FVR) channel
  - Independent input multiplexing
- Analog Comparator module:
  - Two rail-to-rail analog comparators
  - Independent input multiplexing
- Digital-to-Analog Converter (DAC) module:
  - Fixed Voltage Reference (FVR) with 1.024V, 2.048V and 4.096V output levels
  - 5-bit rail-to-rail resistive DAC with positive and negative reference selection
- Charge Time Measurement Unit (CTMU) module:
  - Supports capacitive touch sensing for touch screens and capacitive switches

**Extreme Low-Power Management  
PIC18(L)F2X/4XK22 with XLP:**

- Sleep mode: 20 nA, typical
- Watchdog Timer: 300 nA, typical
- Timer1 Oscillator: 800 nA @ 32 kHz
- Peripheral Module Disable

**Special Microcontroller Features:**

- 2.3V to 5.5V Operation – PIC18FXXK22 devices
- 1.8V to 3.6V Operation – PIC18LFXXK22 devices
- Self-Programmable under Software Control
- High/Low-Voltage Detection (HLVD) module:
  - Programmable 16-Level
  - Interrupt on High/Low-Voltage Detection
- Programmable Brown-out Reset (BOR):
  - With software enable option
  - Configurable shutdown in Sleep
- Extended Watchdog Timer (WDT):
  - Programmable period from 4 ms to 131s
- In-Circuit Serial Programming™ (ICSP™):
  - Single-Supply 3V
- In-Circuit Debug (ICD)

**Peripheral Highlights:**

- Up to 35 I/O Pins plus 1 Input-Only Pin:
  - High-Current Sink/Source 25 mA/25 mA
  - Three programmable external interrupts
  - Four programmable interrupt-on-change
  - Nine programmable weak pull-ups
  - Programmable slew rate
- SR Latch:
  - Multiple Set/Reset input options
- Two Capture/Compare/PWM (CCP) modules
- Three Enhanced CCP (ECCP) modules:
  - One, two or four PWM outputs
  - Selectable polarity
  - Programmable dead time
  - Auto-Shutdown and Auto-Restart
  - PWM steering
- Two Master Synchronous Serial Port (MSSP) modules:
  - 3-wire SPI (supports all 4 modes)
  - I<sup>2</sup>C™ Master and Slave modes with address mask

# PIC18(L)F2X/4XK22

- Two Enhanced Universal Synchronous Asynchronous Receiver Transmitter (EUSART) modules:
  - Supports RS-485, RS-232 and LIN
  - RS-232 operation using internal oscillator
  - Auto-Wake-up on Break
  - Auto-Baud Detect

Device	Program Memory		Data Memory		I/O <sup>(1)</sup>	10-bit A/D Channels <sup>(2)</sup>	CCP	ECCP (Full-Bridge)	ECCP (Half-Bridge)	MSSP		EUSART	Comparator	CTMU	BOR/LVD	SR Latch	8-bit Timer	16-bit Timer
	Flash (Bytes)	# Single-Word Instructions	SRAM (Bytes)	EEPROM (Bytes)						SPI	I <sup>2</sup> C™							
PIC18(L)F23K22	8K	4096	512	256	25	19	2	1	2	2	2	2	2	Y	Y	Y	3	4
PIC18(L)F24K22	16K	8192	768	256	25	19	2	1	2	2	2	2	2	Y	Y	Y	3	4
PIC18(L)F25K22	32K	16384	1536	256	25	19	2	1	2	2	2	2	2	Y	Y	Y	3	4
PIC18(L)F26K22	64k	32768	3896	1024	25	19	2	1	2	2	2	2	2	Y	Y	Y	3	4
PIC18(L)F43K22	8K	4096	512	256	36	30	2	2	1	2	2	2	2	Y	Y	Y	3	4
PIC18(L)F44K22	16K	8192	768	256	36	30	2	2	1	2	2	2	2	Y	Y	Y	3	4
PIC18(L)F45K22	32K	16384	1536	256	36	30	2	2	1	2	2	2	2	Y	Y	Y	3	4
PIC18(L)F46K22	64k	32768	3896	1024	36	30	2	2	1	2	2	2	2	Y	Y	Y	3	4

**Note 1:** One pin is input only.

**2:** Channel count includes internal FVR and DAC channels.

# PIC18(L)F2X/4XK22

## Pin Diagrams (28-pin)

### 28-pin PDIP, SOIC, SSOP

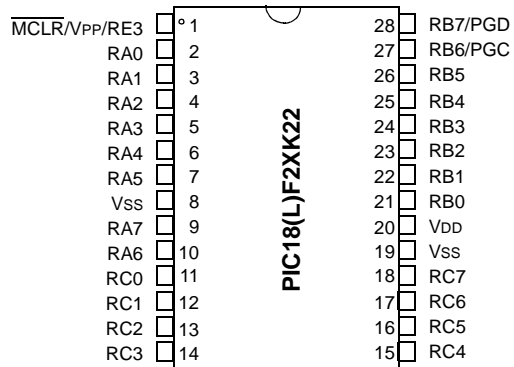

### 28-pin QFN, UQFN<sup>(1)</sup>

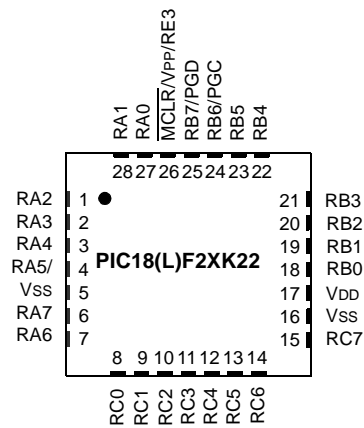

**Note 1:** The 28-pin UQFN package is available only for PIC18(L)F23K22 and PIC18(L)F24K22.

# PIC18(L)F2X/4XK22

## Pin Diagrams (40-pin)

40-pin PDIP

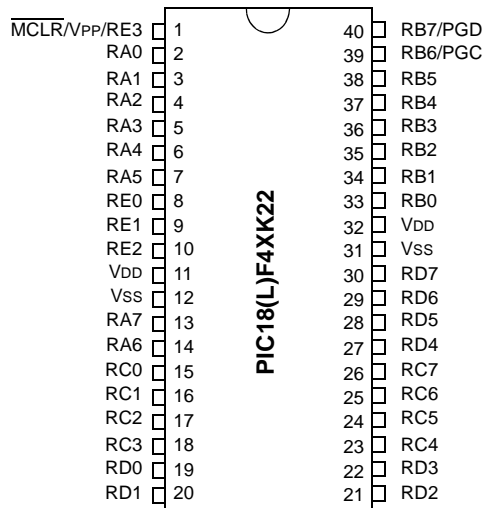

40-pin UQFN

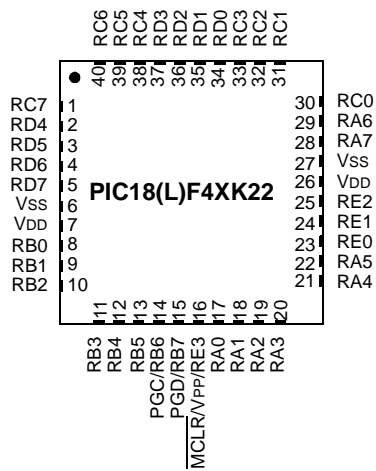

# PIC18(L)F2X/4XK22

## Pin Diagrams (44-pin)

### 44-pin TQFP

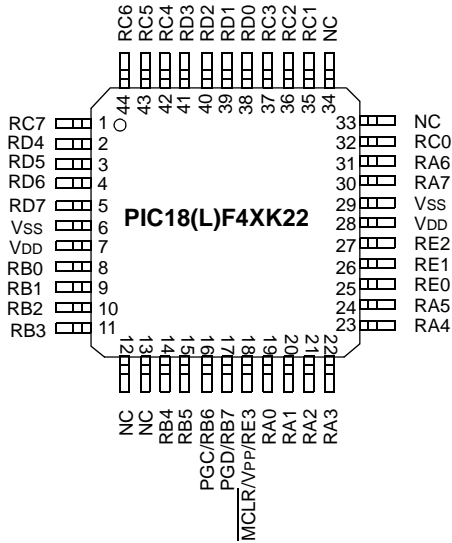

### 44-pin QFN

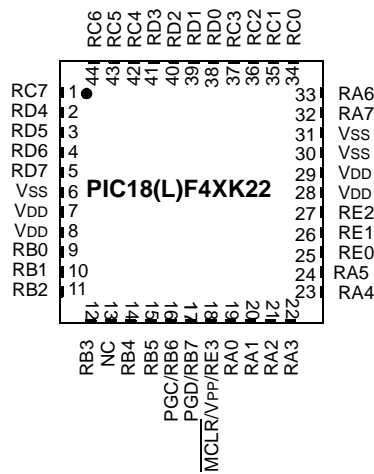

# PIC18(L)F2X/4XK22

**TABLE 1: PIC18(L)F2XK22 PIN SUMMARY**

28-SSOP, SOIC 28-SPDIP	28-QFN, UQFN	I/O	Analog	Comparator	CTMU	SR Latch	Reference	(E)CCP	EUSART	MSSP	Timers	Interrupts	Pull-up	Basic
2	27	RA0	AN0	C12IN0-										
3	28	RA1	AN1	C12IN1-										
4	1	RA2	AN2	C2IN+			VREF- DACOUT							
5	2	RA3	AN3	C1IN+			VREF+							
6	3	RA4		C1OUT		SRQ		CCP5			T0CKI			
7	4	RA5	AN4	C2OUT		SRNQ	HLVDIN			SS1				
10	7	RA6												OSC2 CLKO
9	6	RA7												OSC1 CLKI
21	18	RB0	AN12			SRI		CCP4 FLT0		SS2		INT0	Y	
22	19	RB1	AN10	C12IN3-				P1C		SCK2 SCL2		INT1	Y	
23	20	RB2	AN8		CTED1			P1B		SDI2 SDA2		INT2	Y	
24	21	RB3	AN9	C12IN2-	CTED2			CCP2 P2A <sup>(1)</sup>		SDO2			Y	
25	22	RB4	AN11					P1D			T5G	IOC	Y	
26	23	RB5	AN13					CCP3 P3A <sup>(4)</sup> P2B <sup>(3)</sup>			T1G T3CKI <sup>(2)</sup>	IOC	Y	
27	24	RB6							TX2/CK2			IOC	Y	PGC
28	25	RB7							RX2/DT2			IOC	Y	PGD
11	8	RC0						P2B <sup>(3)</sup>			SOSCO T1CKI T3CKI <sup>(2)</sup> T3G			
12	9	RC1						CCP2 P2A <sup>(1)</sup>			SOSCI			
13	10	RC2	AN14		CTPLS			CCP1 P1A			T5CKI			
14	11	RC3	AN15							SCK1 SCL1				
15	12	RC4	AN16							SDI1 SDA1				
16	13	RC5	AN17							SDO1				
17	14	RC6	AN18					CCP3 P3A <sup>(4)</sup>	TX1/CK1					
18	15	RC7	AN19					P3B	RX1/DT1					
1	26	RE3												MCLR VPP
8	5													VSS
19	16													VSS
20	17													VDD

**Note** 1: CCP2/P2A multiplexed in fuses.  
 2: T3CKI multiplexed in fuses.  
 3: P2B multiplexed in fuses.  
 4: CCP3/P3A multiplexed in fuses.



# PIC18(L)F2X/4XK22

**TABLE 2: PIC18(L)F4XK22 PIN SUMMARY**

40-PDIP	40-UQFN	44-TQFP	44-QFN	IO	Analog	Comparator	CTMU	SR Latch	Reference	(E)CCP	EUSART	MSSP	Timers	Interrupts	Pull-up	Basic
2	17	19	19	RA0	AN0	C12IN0-										
3	18	20	20	RA1	AN1	C12IN1-										
4	19	21	21	RA2	AN2	C2IN+			VREF- DACOUT							
5	20	22	22	RA3	AN3	C1IN+			VREF+							
6	21	23	23	RA4		C1OUT		SRQ					T0CKI			
7	22	24	24	RA5	AN4	C2OUT		SRNQ	HLVDIN			SS1				
14	29	31	33	RA6												OSC2 CLKO
13	28	30	32	RA7												OSC1 CLKI
33	8	8	9	RB0	AN12			SRI		FLT0				INT0	Y	
34	9	9	10	RB1	AN10	C12IN3-								INT1	Y	
35	10	10	11	RB2	AN8		CTED1							INT2	Y	
36	11	11	12	RB3	AN9	C12IN2-	CTED2			CCP2 P2A <sup>(1)</sup>					Y	
37	12	14	14	RB4	AN11								T5G	IOC	Y	
38	13	15	15	RB5	AN13					CCP3 P3A <sup>(3)</sup>			T1G T3CKI <sup>(2)</sup>	IOC	Y	
39	14	16	16	RB6										IOC	Y	PGC
40	15	17	17	RB7										IOC	Y	PGD
15	30	32	34	RC0						P2B <sup>(4)</sup>			SOSCO T1CKI T3CKI <sup>(2)</sup> T3G			
16	31	35	35	RC1						CCP2 <sup>(1)</sup> P2A			SOSCI			
17	32	36	36	RC2	AN14		CTPLS			CCP1 P1A			T5CKI			
18	33	37	37	RC3	AN15							SCK1 SCL1				
23	38	42	42	RC4	AN16							SDI1 SDA1				
24	39	43	43	RC5	AN17							SDO1				
25	40	44	44	RC6	AN18											
26	1	1	1	RC7	AN19											
19	34	38	38	RD0	AN20								SCK2 SCL2			
20	35	39	39	RD1	AN21					CCP4			SDI2 SDA2			
21	36	40	40	RD2	AN22					P2B <sup>(4)</sup>						
22	37	41	41	RD3	AN23					P2C		SS2				
27	2	2	2	RD4	AN24					P2D		SD02				
28	3	3	3	RD5	AN25					P1B						
29	4	4	4	RD6	AN26					P1C						
30	5	5	5	RD7	AN27					P1D						
8	23	25	25	RE0	AN5					CCP3 P3A <sup>(3)</sup>						

**Note** 1: CCP2 multiplexed in fuses.  
 2: T3CKI multiplexed in fuses.  
 3: CCP3/P3A multiplexed in fuses.  
 4: P2B multiplexed in fuses.

# PIC18(L)F2X/4XK22

**TABLE 2: PIC18(L)F4XK22 PIN SUMMARY (CONTINUED)**

40-PDIP	40-UQFN	44-TQFP	44-QFN	I/O	Analog	Comparator	CTMU	SR Latch	Reference	(E)CCP	EUSART	MSSP	Timers	Interrupts	Pull-up	Basic
9	24	26	26	RE1	AN6					P3B						
10	25	27	27	RE2	AN7					CCP5						
1	16	18	18	RE3											Y	MCLR V <sub>PP</sub>
11 32	7, 26	7 28	7,8 28, 29													V <sub>DD</sub>
12 31	6, 27	6 29	6 30, 31													V <sub>SS</sub>
—	—	12, 13 33, 34	13	NC												

- Note**
- 1: CCP2 multiplexed in fuses.
  - 2: T3CKI multiplexed in fuses.
  - 3: CCP3/P3A multiplexed in fuses.
  - 4: P2B multiplexed in fuses.