

V 1.01

HARDWARE MANUAL



TMCM-1180

PD86-1180

1-axis stepper
controller / driver
5.5A RMS/ 24 or 48V DC
USB, RS232, RS485, and CAN



stallGuard2™

TRINAMIC Motion Control GmbH & Co. KG
Hamburg, Germany

www.trinamic.com



Table of contents

1	Life support policy	3
2	Features	4
3	Order codes	5
4	Mechanical and electrical interfacing	6
4.1	TMC-1180 dimensions and mounting holes	6
4.2	PD86-1180 dimensions and motor specifications	7
4.2.1	Dimensions of PD86-3-1180	7
4.2.2	Motor specifications of QSH8618-96-55-700	8
4.2.3	Torque figure of QSH8618-96-55-700	9
4.3	Connectors of TMC-1180	10
4.3.1	Power connector	11
4.3.2	Serial communication connector	12
4.3.3	USB connector	12
4.3.4	Output connector	13
4.3.5	Input connector	14
4.3.6	Step/Direction connector	16
4.3.7	Encoder connector	17
4.3.8	Motor connector and specifications	18
5	Jumpers	19
5.1	RS485 bus termination	19
5.2	CAN bus termination	19
6	Operational ratings	20
7	Functional description	21
7.1	System architecture	21
7.1.1	Microcontroller	21
7.1.2	EEPROM	22
7.1.3	TMC428 motion controller	22
7.1.4	Stepper motor driver	22
7.1.5	sensOstep™ encoder	23
8	TMC-1180 operational description	24
8.1	Calculation: Velocity and acceleration vs. microstep and fullstep frequency	24
9	TMCL™	26
10	CANopen	27
11	Revision history	28
11.1	Document revision	28
11.2	Hardware revision	28
12	References	29

1 Life support policy

TRINAMIC Motion Control GmbH & Co. KG does not authorize or warrant any of its products for use in life support systems, without the specific written consent of TRINAMIC Motion Control GmbH & Co. KG.

Life support systems are equipment intended to support or sustain life, and whose failure to perform, when properly used in accordance with instructions provided, can be reasonably expected to result in personal injury or death.

© TRINAMIC Motion Control GmbH & Co. KG 2011

Information given in this data sheet is believed to be accurate and reliable. However neither responsibility is assumed for the consequences of its use nor for any infringement of patents or other rights of third parties, which may result from its use.

Specifications are subject to change without notice.



2 Features

The PD86-1180 is a full mechatronic device consisting of a NEMA 34 (flange size 86mm) stepper motor, controller/driver electronics and integrated encoder.

Applications

- Powerful single-axis stepper motor solutions
- Encoder feedback for high reliability operation

Electrical data

- Supply voltage: +24V DC or +48V DC nominal
- Motor current: up to 5.5A RMS (programmable)

PANdrive motor

- Two phase bipolar stepper motor with up to 5.5A RMS nom. coil current
- Holding torque: 7Nm

Integrated encoder

- Integrated sensOstep™ magnetic encoder (max. 256 increments per rotation) e.g. for step-loss detection under all operating conditions and positioning

Integrated motion controller

- Motion profile calculation in real-time (TMC428 motion controller)
- On the fly alteration of motor parameters (e.g. position, velocity, acceleration)
- High performance ARM7 microcontroller for overall system control and serial communication protocol handling

Integrated bipolar stepper motor driver

- Up to 256 microsteps per full step
- High-efficient operation, low power dissipation (MOSFETs with low $R_{DS(ON)}$)
- Dynamic current control
- Integrated protection
- Automatic load dependent motor current adaptation for reduced power consumption and heat dissipation (coolStep™)

Interfaces

- inputs for stop switches (left and right) and home switch
- general purpose inputs and 2 general purpose outputs
- USB, RS232, RS485 and CAN (2.0B up to 1Mbit/s) communication interfaces

Safety features

- Shutdown input. The driver will be disabled in hardware as long as this pin is left open or shorted to ground
- Separate supply voltage inputs for driver and digital logic – driver supply voltage may be switched off externally while supply for digital logic and therefore digital logic remains active

Software

- TMCL™: stand-alone operation or remote controlled operation
- TMCL™: program memory (non volatile) for up to 2048 TMCL™ commands
- TMCL™: PC-based application development software TMCL-IDE available for free
- CANopen (under development): CiA 301 + CiA 402 (homing mode, profile position mode and velocity mode) supported

Please see separate TMCL™ and CANopen Firmware Manuals for additional information

3 Order codes

Order code	Description	Dimensions
TMCM-1180-TMCL	TMCM-1180 with coolStep™, sensOstep™, and TMCL™ Firmware	85.9 x 85.9 x 21.5
TMCM-1180-CANopen	TMCM-1180 with coolStep™, sensOstep™, and CANopen Firmware (<i>under development</i>)	85.9 x 85.9 x 21.5
PD86-3-1180-TMCL	PD86-3-1180 with coolStep™, sensOstep™, and TMCL™ Firmware, 7.0 Nm	85.9 x 85.9 x 118.5
PD86-3-1180-CANopen	PD86-3-1180 with coolStep™, sensOstep™, and CANopen Firmware, 7.0 Nm	85.9 x 85.9 x 118.5
TMCM-1180-Cable	Cable loom for TMCM-1180	
Related Motor:		
QSH8618-96-55-700	QMot stepper motor 86mm, 5.5A, 7.0Nm	85.85 x 85.85 x 96.0

Table 3.1: Order codes

4 Mechanical and electrical interfacing

4.1 TMCM-1180 dimensions and mounting holes

The dimensions of the controller/driver board (TMCM-1180) are approx. 86mm x 86mm in order to fit to the back side of the 86mm stepper motor. The TMCM-1180 is 21.5mm high without matching connectors. There are four mounting holes for M4 screws.

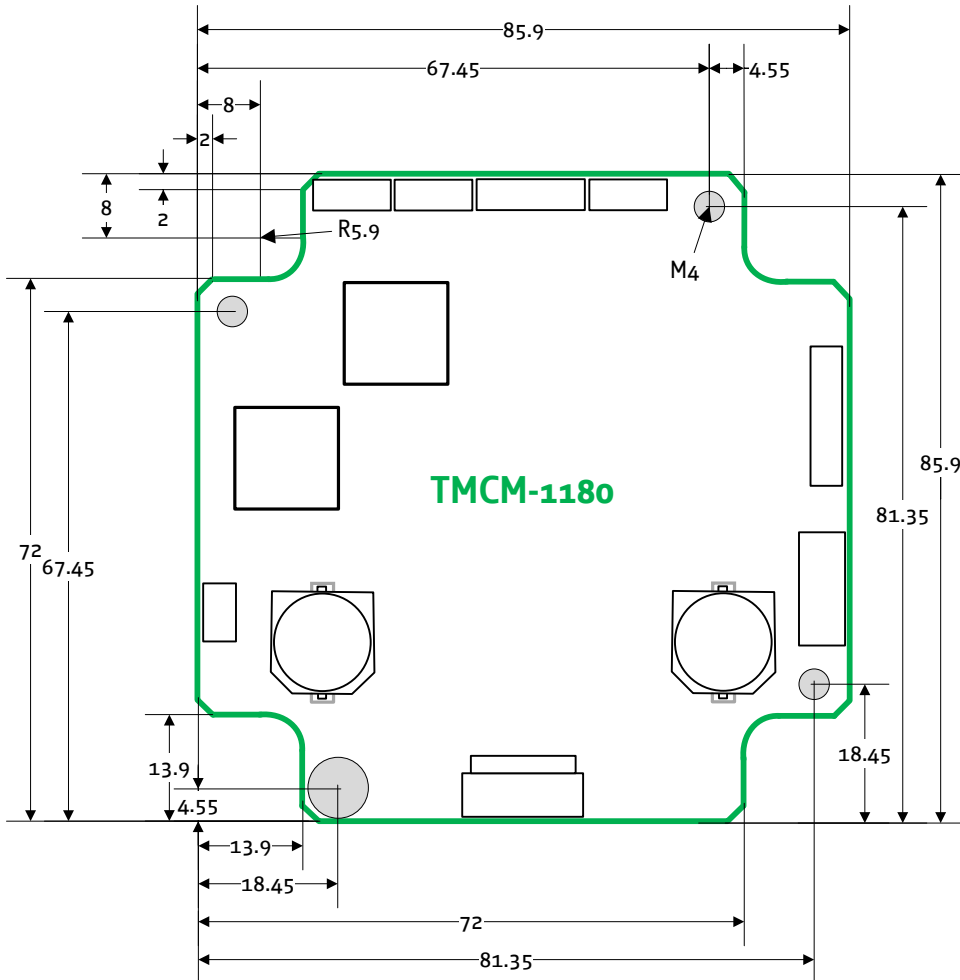


Figure 4.1: Dimensions of TMCM-1180 and mounting holes

4.2.2 Motor specifications of QSH8618-96-55-700

Specifications	Units	QSH8618-96-55-700
Wiring		
Rated Voltage	V	2.56
Rated Phase Current (nominal)	A	5.5
Phase Resistance at 20°C	Ω	0.45
Phase Inductance (typ.)	mH	4.5
Holding Torque (typ.)	Nm	7.0
Detent Torque	Nm	
Rotor Inertia	gcm ²	2700
Weight (Mass)	Kg	2.8
Insulation Class		B
Insulation Resistance	Ω	100M
Dialectic Strength (for one minute)	VAC	500
Connection Wires	N°	4
Max applicable Voltage	V	140
Step Angle	°	1.8
Step angle Accuracy	%	5
Flange Size (max.)	mm	85.85
Motor Length (max.)	mm	96
Axis Diameter	mm	12.7
Axis Length (visible part, typ.)	mm	31.75
Axis D-cut (1.1mm depth)	mm	25.0
Shaft Radial Play (450g load)	mm	0.02
Shaft Axial Play (450g load)	mm	0.08
Maximum Radial Force (20 mm from front flange)	N	220
Maximum Axial Force	N	60
Ambient Temperature	°C	-20... +50
Temp Rise (rated current, 2 phase on)	°C	max. 80

Table 4.1: Motor specifications of QSH8618-96-55-700

4.2.3 Torque figure of QSH8618-96-55-700

The torque figure details the motor torque characteristics for full step operation in order to allow simple comparison. For full step operation there are always a number of resonance points (with less torque) which are not depicted. These will be minimized by microstep operation.

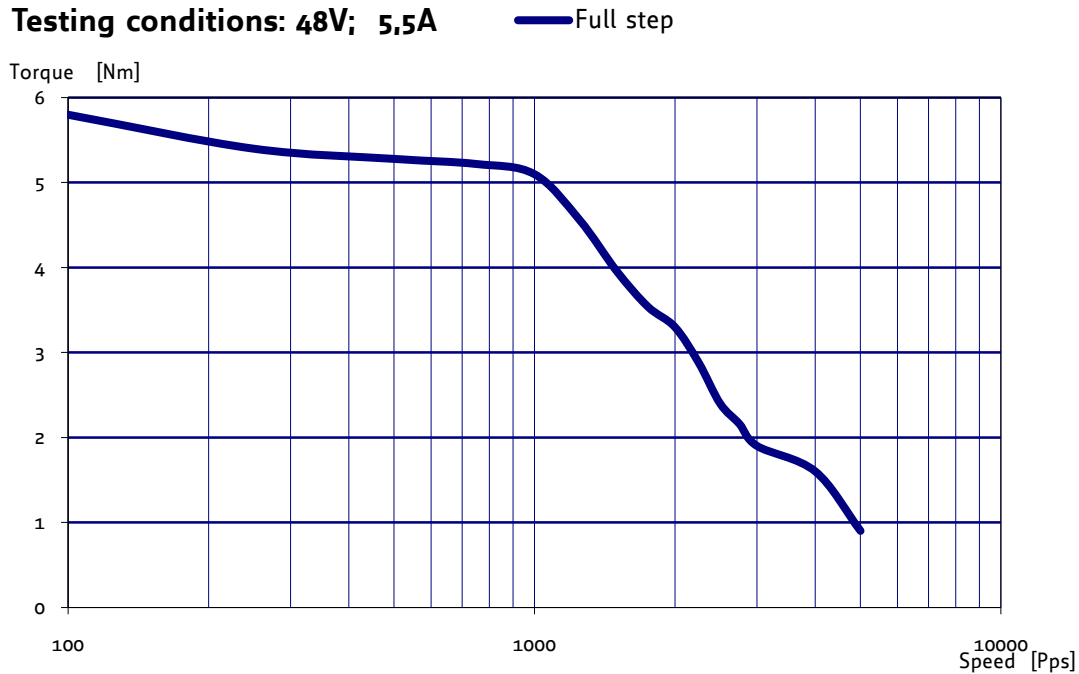


Figure 4.3: QSH8618-96-55-700 speed vs. torque characteristics

4.3 Connectors of TMCM-1180

The controller/driver board for the PD86-1180 offers eight connectors including the motor connector which is used internally for attaching the motor coils to the electronics. In addition to the power connector there are two connectors for serial communication (one for min-USB and one for RS232/RS485/CAN) and two connectors for additional input and output signals. Further there is one connector for Step/Direction and another for the encoder.

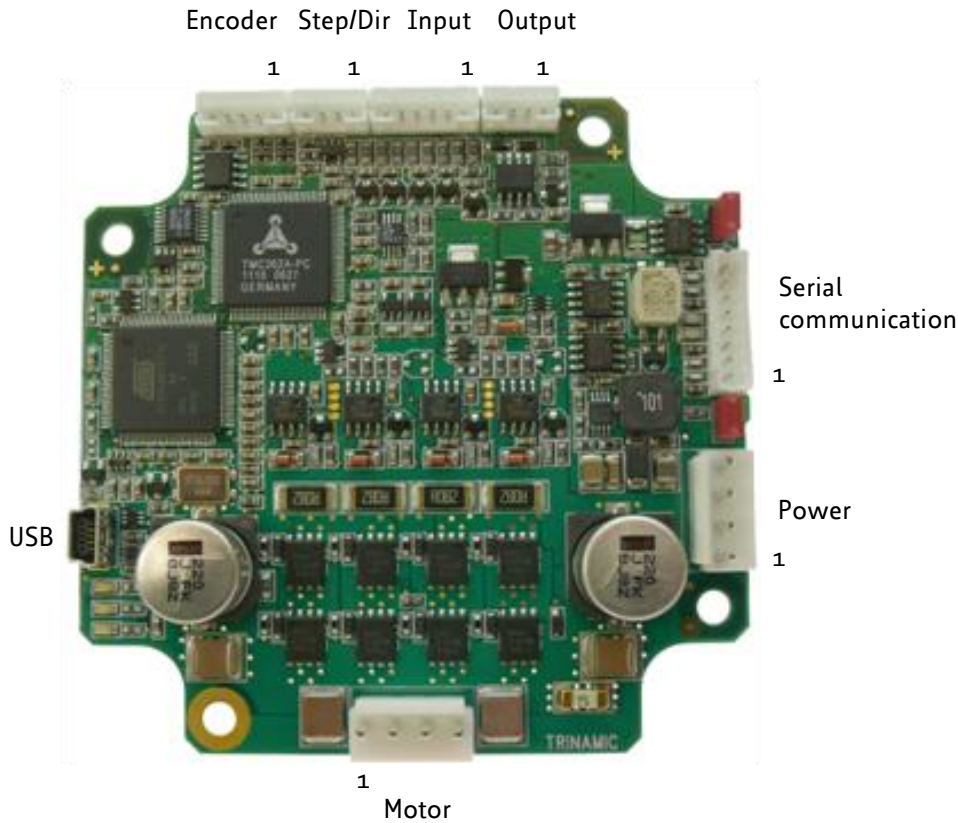


Figure 4.4: Overview connectors

The output connector offers two general purpose outputs, one power supply voltage output and one hardware shutdown-input. Leaving the shutdown input open or tying it to ground will disable the motor driver stage in hardware. For operation, this input should be tied to the supply voltage.

The input connector offers two inputs for stop switches (left and right), one home switch input, two general purpose inputs and one connection to the system or signal ground.

4.3.1 Power connector

This module offers separate power supply inputs for digital logic (connector pin 2) and driver/power stage (connector pin 1). Both supply inputs use common ground connections (connector pin 3 and 4). This way, power supply for the driver stage may be switched off while still maintaining position and status information when keeping digital logic supply active. In case power supply is provided to the power section only, an internal diode will distribute power to the logic section also. So, when separate power supplies are not required it is possible to just use pin 1 and 4 for powering the module.

A 4-pin JST B04P-VL connector is used for power supply.

Mating connector housing: JST VHR-4N

Mating connector crimp contacts: JST SVF-61T-P2.0


	Pin	Label	Description
	1	$+U_{\text{Driver}}$	Module + driver stage power supply input (nom. +48V DC)
	2	$+U_{\text{Logic}}$	(Optional) separate digital logic power supply input (nom. +48V DC)
	3	GND	Module ground (power supply and signal ground)
	4	GND	Module ground (power supply and signal ground)

Table 4.2: Connector for power supply

Please note, that there is no protection against reverse polarity or voltages above the upper maximum limit. The power supply typically should be within a range of 24 to 48V.

When using supply voltages near the upper limit, a regulated power supply is mandatory. Please ensure, that enough power filtering capacitors are available in the system (2200 μ F or more recommended) in order to absorb mechanical energy fed back by the motor in stalling conditions. In larger systems a zener diode circuitry might be required in order to limit the maximum voltage when the motor is operated at high velocities.

The power supply should be designed in a way, that it supplies the nominal motor voltage at the desired maximum motor power. **In no case shall the supply value exceed the upper voltage limit.**

To ensure reliable operation of the unit, the power supply has to have a sufficient output capacitor and the supply cables should have a low resistance, so that the chopper operation does not lead to an increased power supply ripple directly at the unit. Power supply ripple due to the chopper operation should be kept at a maximum of a few 100mV.

Guidelines for power supply:

- keep power supply cables as short as possible
- use large diameters for power supply cables
- add 2200 μ F or larger filter capacitors near the motor driver unit especially if the distance to the power supply is large (i.e. more than 2-3m)

4.3.2 Serial communication connector

A 2mm pitch 8 pin JST B8B-PH-K connector is used for serial communication. With this connector the module supports RS232, RS485 and CAN communication.

Mating connector housing: PHR-8

Mating connector contacts: SPH-002T-P0.5S.


	Pin	Label	Description
	1	RS232_TxD	RS232 transmit data
	2	RS232_RxD	RS232 receive data
	3	GND	Module ground (system and signal ground)
	4	CAN_H	CAN_H bus line (dominant high)
	5	CAN_L	CAN_L bus line (dominant low)
	6	GND	Module ground (system and signal ground)
	7	RS485+	RS485 non-inverted bus signal
	8	RS485-	RS485 inverted bus signal

Table 3.3: Connector for serial communication

4.3.3 USB connector

A 5-pin mini-USB connector is available on board (might depend on assembly option).


	Pin	Label	Description
	1	VBUS	+5V power
	2	D-	Data -
	3	D+	Data +
	4	ID	Not connected
	5	GND	ground

Table 3.4: Mini USB connector

4.3.4 Output connector

A 2mm pitch 4 pin JST B4B-PH-K connector is used for connecting the two general purpose outputs and the driver stage hardware shutdown input pin to the unit.

Attention: In order to enable the motor driver stage connect /Shutdown (pin 2) to +U_{Logic} (pin 1)!

Mating connector housing: PHR-4

Mating connector contacts: SPH-002T-P0.5S

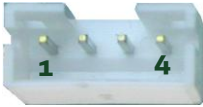
	Pin	Label	Description
	1	+U _{Logic}	Module digital logic power supply – connected to pin 2 of power supply connector
	2	/Shutdown	/Shutdown input – has to be connected to power supply (e.g. pin 1 of this connector) in order to enable driver. Connecting this input to ground or leaving it unconnected will disable driver stage
	3	OUT_o	Open collector output with integrated freewheeling diode, +24V compatible
	4	OUT_1	Open collector output with integrated freewheeling diode, +24V compatible

Table 4.3: Output / /Shutdown connector

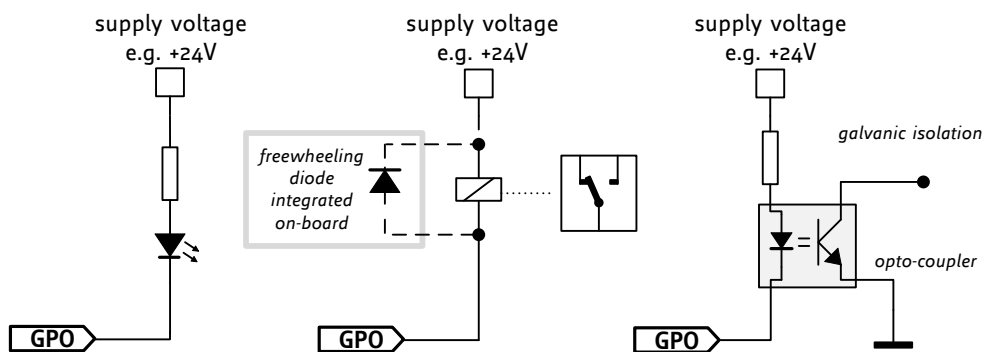


Figure 4.5: Possible circuits for GPO

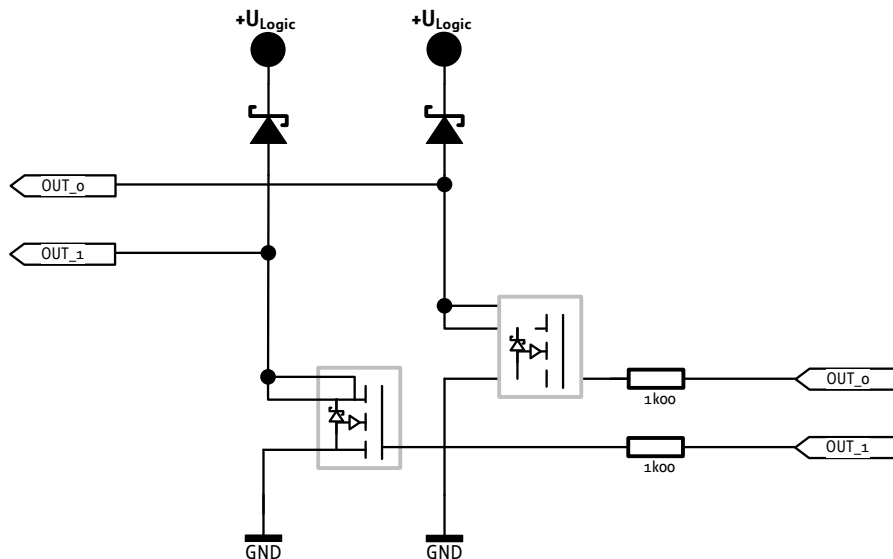


Figure 4.6: Internal circuit of the outputs

4.3.5 Input connector

A 2mm pitch 6 pin JST B6B-PH-K connector is used for connecting general purpose inputs, home and stop switches to the unit.

Mating connector housing: PHR-6

Mating connector contacts: SPH-002T-P0.5S

Pin	Label	Description
1	IN_0	General purpose input, +24V compatible
2	IN_1	General purpose input, +24V compatible
3	STOP_L	Left stop switch input, +24V compatible, programmable internal pull-up (1k to +5V)
4	STOP_R	Right stop switch input, +24V compatible, programmable internal pull-up (1k to +5V)
5	HOME	Home switch input, +24V compatible, programmable internal pull-up (1k to +5V)
6	GND	Module ground (system and signal ground)

Table 4.4: Input / Stop / Home switch connector

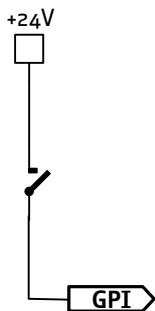


Figure 4.7: Possible circuit for GPI

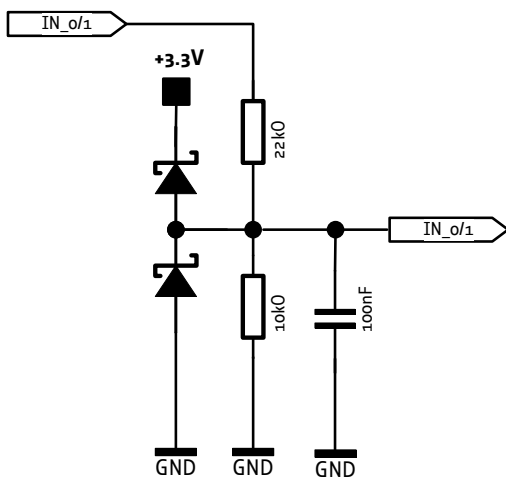


Figure 4.8: Internal circuit of the inputs

4.3.5.1 Left and right limit switches

The TMCM-1180 can be configured so that a motor has a left and a right limit switch (Figure 4.9).

The motor stops when the traveler has reached one of the limit switches.

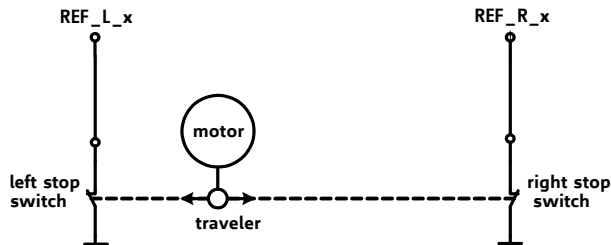


Figure 4.9: Left and right limit switches

4.3.5.2 Triple switch configuration

It is possible to program a tolerance range around the reference switch position. This is useful for a triple switch configuration, as outlined in Figure 4.10. In that configuration two switches are used as automatic stop switches, and one additional switch is used as the reference switch between the left stop switch and the right stop switch. The left stop switch and the reference switch are wired together. The center switch (travel switch) allows for a monitoring of the axis in order to detect a step loss.

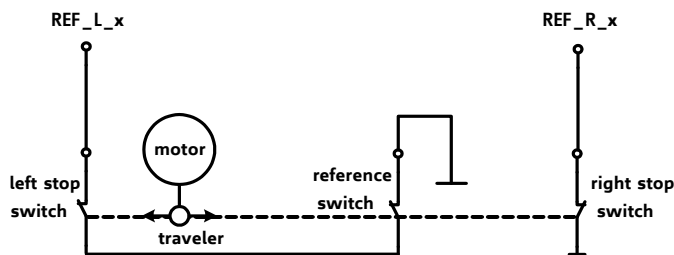


Figure 4.10: Limit switch and reference switch

4.3.5.3 One limit switch for circular systems

If a circular system is used (Figure 4.11), only one reference switch is necessary, because there are no end-points in such a system.

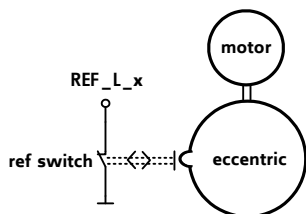


Figure 4.11: One reference switch

4.3.6 Step/Direction connector

A 2mm pitch 4 pin JST B4B-PH-K connector is used for connecting the Step/Dir interface.

Mating connector housing: PHR-4

Mating connector contacts: SPH-002T-P0.5S

Pin	Label	Description
1	OC_COM	Common supply / opto-coupler (+5V .. +24V)
2	OC_EN	Enable signal
3	OC_STEP	Step signal
4	OC_DIR	Direction signal

Table 4.5: Step/Dir connector

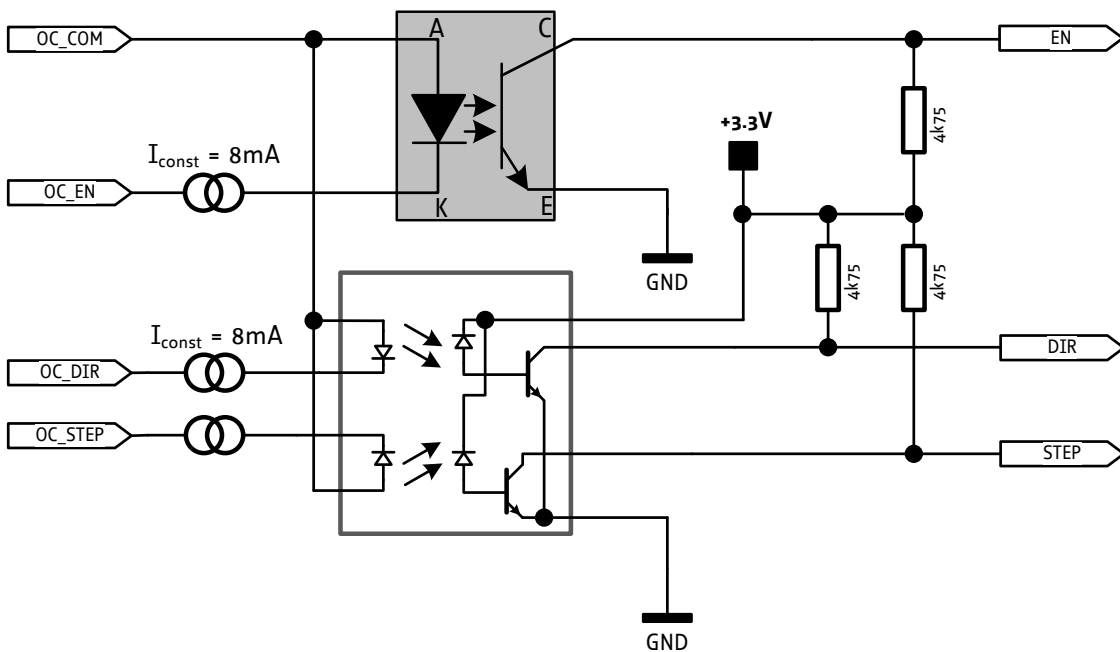


Figure 4.12: Internal circuit of the Step/Dir interface

4.3.7 Encoder connector

A 2mm pitch 5 pin JST B5B-PH-K connector is used for connecting the Encoder.

Mating connector housing: PHR-5

Mating connector contacts: SPH-002T-P0.5S

Pin	Label	Description
1	ENC_A	Encoder A-channel
2	ENC_B	Encoder B-channel
3	ENC_N	Encoder N-channel
4	GND	Power and signal ground
5	+5V_output	+5V output for encoder power supply (max. 100mA)

Table 4.6: Encoder connector

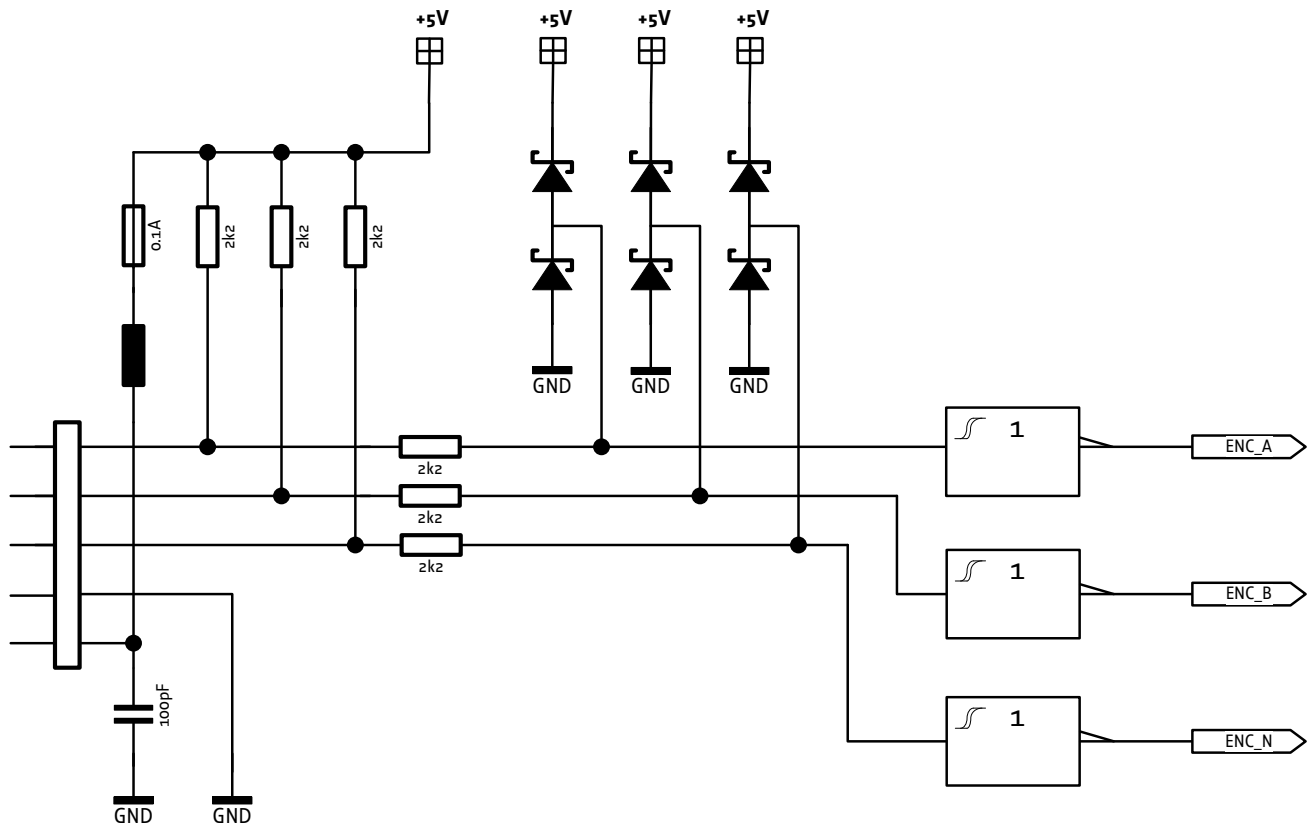


Figure 4.13: Internal circuit of encoder interface

4.3.8 Motor connector and specifications

A 3.96mm pitch 4 pin JST B4P-VH connector is used for motor connection. Both motor coil windings (bipolar stepper motor) are connected to this connector.

Mating connector housing: VHR-4N

Mating connector contacts: BVH-21T-P1.1

Pin	Label	Description
1	OA1	Motor coil A
2	OA2	Motor coil A
3	OB1	Motor coil B
4	OB2	Motor coil B

Table 4.7: Connector for motor

5 Jumpers

Most settings of the board are done through the software. Nevertheless, a few jumpers are available for configuration.

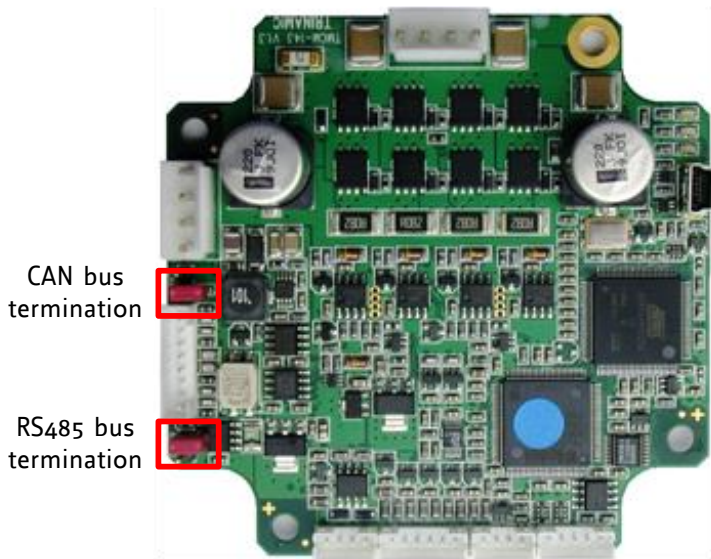


Figure 5.1: RS485 and CAN bus termination

5.1 RS485 bus termination

The board includes a 120 Ohm resistor for proper bus termination of the RS485 interface. When this jumper is closed, the resistor will be placed between the two differential bus lines RS485+ and RS485-.

5.2 CAN bus termination

The board includes a 120 Ohm resistor for proper bus termination of the CAN interface. When this jumper is closed, the resistor will be placed between the two differential bus lines CAN_H and CAN_L.

6 Operational ratings

The operational ratings shown below should be used as design values. In no case should the maximum values been exceeded during operation.

Symbol	Parameter	Min	Typ	Max	Unit
$+U_{\text{Driver}} / +U_{\text{Logic}}$	Power supply voltage for operation	18	24 or 48	55	V DC
$I_{\text{COIL_peak}}$	Motor coil current for sine wave peak (chopper regulated, adjustable via software)	0		7.8	A
$I_{\text{COIL_RMS}}$	Continuous motor current (RMS)	0		5.5	A
I_{SUPPLY}	Power supply current		$\ll I_{\text{COIL}}$	$1.4 * I_{\text{COIL}}$	A
T_{ENV}	Environment temperature at rated current (no forced cooling required)	-20		+50 ^{*)}	°C

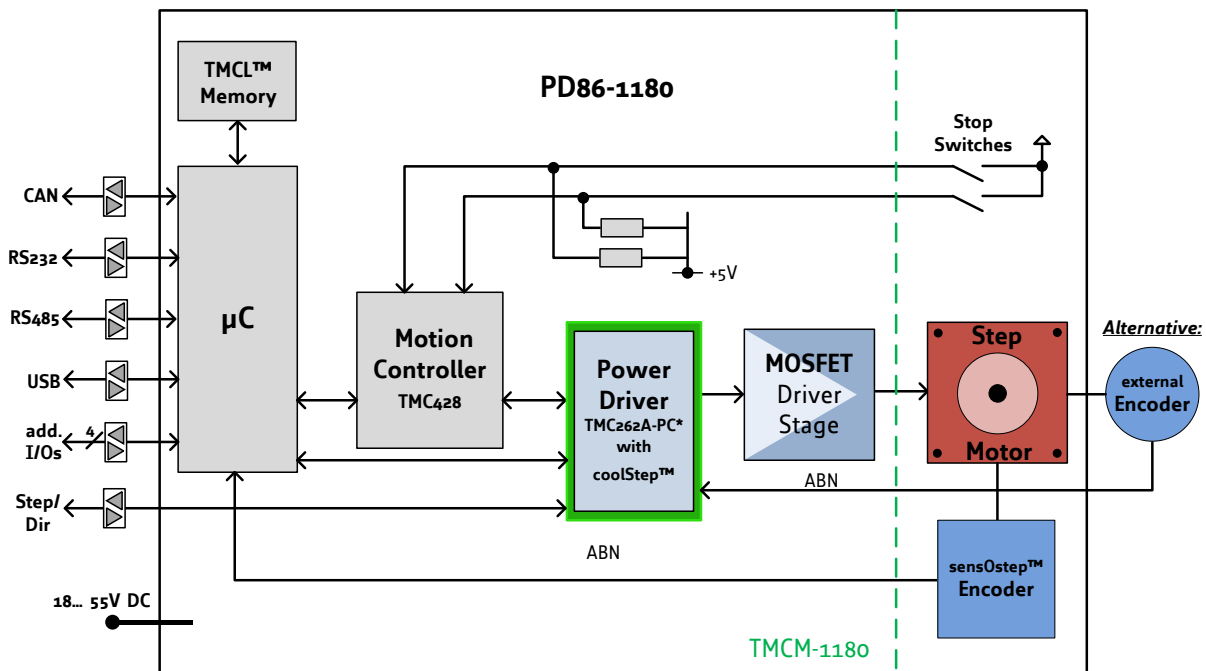
Table 4.6.1: General operational ratings of the module

*) The controller driver electronics has been tested inside a climate chamber running at full current (5.5A RMS) for 30min without air convection at 50°C environmental temperature.

Please note: The motor might heat up well above 50°C when running at full current without proper cooling. This might substantially increase the environmental temperature for the electronics. When using the coolStep™ operation mode, the actual current might be substantially less than programmed max. current producing and temperature.

7 Functional description

In figure 7.1 the main parts of the PD86-1180 are shown. The PANdrive™ mainly consists of the μ C (connected to the EEPROM TMCL™ memory), the TMC428 motion controller, the TMC262A-PC power driver with its energy efficient coolStep™ feature, the external MOSFET driver stage, the QSH8618 stepper motor, and the integrated sensOstep™ encoder. Alternatively it is possible to connect an external encoder. Nominal supply voltages are 24VDC or 48VDC.



* TMC262A-PC is a special driver version of TMC262 for PD86-3-1180 with slightly different characteristics

Figure 7.1: Main parts of the PD86-1180

7.1 System architecture

The TCM-1180 integrates a microcontroller with the TMCL™ (Trinamic Motion Control Language) operating system. The motion control real-time tasks are realized by the TMC428.

7.1.1 Microcontroller

On this module, the Atmel AT91SAM7X256 is used to run the TMCL™ operating system and to control the TMC428. The CPU has 256KB flash memory and a 64KB RAM. The microcontroller runs the TMCL™ (Trinamic Motion Control Language) operating system which makes it possible to execute TMCL™ commands that are sent to the module from the host via the RS232, RS485, USB, or CAN interface. The microcontroller interprets the TMCL™ commands and controls the TMC428 which executes the motion commands. In addition it is connected with the encoder interface and processes the inputs.

The flash ROM of the microcontroller holds the TMCL™ operating system. The TMCL™ operating system can be updated via the RS232 interface or via the CAN interface. Use the TMCL-IDE to do this.

7.1.2 EEPROM

To store TMCL™ programs for stand-alone operation the TMCM-1180 module is equipped with a 16kByte EEPROM attached to the microcontroller. The EEPROM can store TMCL™ programs consisting of up to 2048 TMCL™ commands. The EEPROM is also used to store configuration data.

7.1.3 TMC428 motion controller

The TMC428 is a high-performance stepper motor control IC and can control up to three 2-phase-stepper-motors. Motion parameters like speed or acceleration are sent to the TMC428 via SPI by the microcontroller. Calculation of ramps and speed profiles are done internally by hardware based on the target motion parameters.

7.1.4 Stepper motor driver



The TMC262A-PC is an energy efficient high current high precision microstepping driver IC for bipolar stepper motors. This driver on the TMCM-1180 module is a special version of the TMC262 power driver for PANdrives™ with QSH8618 motors.

Its unique high resolution sensorless load detection stallGuard2™ is used for a special integrated load dependent current control feature called coolStep™. The ability to read out the load and detect an overload makes the TMC262 an optimum choice for drives where a high reliability is desired. The TMC262 can be driven with step/direction signals as well as by serial SPI™.

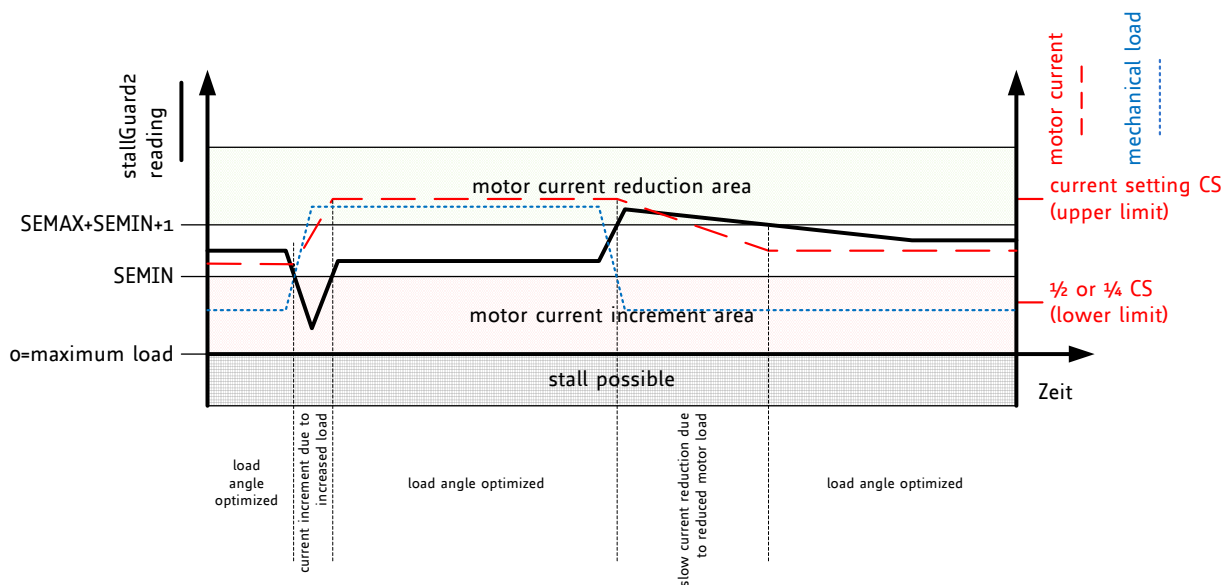


Figure 7.2: Motor current control via coolStep™ adapts motor current to motor load

The coolStep™ current regulator allows to control the reaction of the driver to increasing or decreasing load. The internal regulator uses two thresholds to determine the minimum and the maximum load angle for optimum motor operation. The current increment speed and the current decrement speed can be adapted to the application. Additionally, the lower current limit can be set in relation to the upper current limit set by the current scale parameter CS.

Please refer to the TMC262 Datasheet (www.trinamic.com) for more information.

7.1.5 sensOstep™ encoder

The sensOstep™ encoder used in this unit is based on a magnetic angular position encoder system with low resolution. It consists of a small magnet positioned at the back end of a stepper motor axis and a Hall-sensor IC with integrated digital signal processing (e.g. for automatic gain control, temperature compensation etc.) placed above the magnet on the back side of a motor mounted printed circuit board.

The encoder offers a resolutions of 8 bit (256 steps) per revolution which is completely sufficient for detecting step losses with a standard 1.8° stepper motors.

8 TCM-1180 operational description

8.1 Calculation: Velocity and acceleration vs. microstep and fullstep frequency

The values of the parameters sent to the TMC428 do not have typical motor values like rotations per second as velocity. But these values can be calculated from the TMC428-parameters as shown in this section.

The parameters for the TMC428 are:

Signal	Description	Range
f_{CLK}	clock-frequency	0... 16 MHz
velocity	-	0... 2047
a_max	maximum acceleration	0... 2047
pulse_div	divider for the velocity. The higher the value is, the less is the maximum velocity default value = 0	0... 13
ramp_div	divider for the acceleration. The higher the value is, the less is the maximum acceleration default value = 0	0... 13
Usrs	microstep-resolution (microsteps per fullstep = 2^{usrs})	0... 7 (a value of 7 is internally mapped to 6 by the TMC428)

Table 8.1: TMC428 velocity parameters

The **microstep-frequency** of the stepper motor is calculated with

$$\text{usf [Hz]} = \frac{f_{\text{CLK}} [\text{Hz}] \cdot \text{velocity}}{2^{\text{pulse_div}} \cdot 2048 \cdot 32} \quad \text{with usf: microstep-frequency}$$

To calculate the **fullstep-frequency** from the microstep-frequency, the microstep-frequency must be divided by the number of microsteps per fullstep.

$$\text{fsf [Hz]} = \frac{\text{usf [Hz]}}{2^{\text{usrs}}} \quad \text{with fsf: fullstep-frequency}$$

The change in the pulse rate per time unit (pulse frequency change per second – the **acceleration a**) is given by

$$a = \frac{f_{\text{CLK}}^2 \cdot a_{\text{max}}}{2^{\text{pulse_div} + \text{ramp_div} + 29}}$$

This results in acceleration in fullsteps of:

$$\text{af} = \frac{a}{2^{\text{usrs}}} \quad \text{with af: acceleration in fullsteps}$$

Example:

Signal	value
f_CLK	16 MHz
velocity	1000
a_max	1000
pulse_div	1
ramp_div	1
usrs	6

$$\text{msf} = \frac{16\text{MHz} \cdot 1000}{2^1 \cdot 2048 \cdot 32} = \underline{\underline{122070.31\text{Hz}}}$$

$$\text{fsf}[\text{Hz}] = \frac{122070.31}{2^6} = \underline{\underline{1907.34\text{Hz}}}$$

$$a = \frac{(16\text{MHz})^2 \cdot 1000}{2^{1+1+29}} = \underline{\underline{119.21 \frac{\text{MHz}}{\text{s}}}}$$

$$af = \frac{119.21 \frac{\text{MHz}}{\text{s}}}{2^6} = \underline{\underline{1.863 \frac{\text{MHz}}{\text{s}}}}$$

Calculation of the number of rotations:

A stepper motor has e.g. 72 fullsteps per rotation.

$$\text{RPS} = \frac{\text{fsf}}{\text{fullsteps per rotation}} = \frac{1907.34}{72} = 26.49$$

$$\text{RPM} = \frac{\text{fsf} \cdot 60}{\text{fullsteps per rotation}} = \frac{1907.34 \cdot 60}{72} = 1589.46$$

9 TMCL™

TMCL™, the TRINAMIC Motion Control Language, is described in separate documentations, which refer to the specific products (e.g. TMC-1180 TMCL™ Firmware Manual). The manuals are provided on the TMC TechLibCD and on www.trinamic.com. Please refer to these sources for updated data sheets and application notes.

The TMC TechLibCD includes data sheets, application notes, and schematics of evaluation boards, software of evaluation boards, source code examples, parameter calculation spreadsheets, tools, and more.

10 CANopen

The TMC-1180 module should also be used with the CANopen protocol in future versions. For this purpose, a special CANopen firmware is under development. Please contact TRINAMIC if you are interested in this option.

11 Revision history

11.1 Document revision

Version	Date	Author	Description
0.90	2009-AUG-04	GE	Initial version
0.91	2009-NOV-11	GE	New hardware included
1.00	2010-JUN-28	SD	New engineering detail drawings. Functional and operational descriptions added.
1.01	2011-MAR-21	SD	New front page, minor changes

Table 11.1: Document revision

11.2 Hardware revision

Version	Date	Description
1.00	2009-JUL-6	First 5 prototypes
1.10	2009-SEP-16	Pre-series version
1.20	2009-DEC-17	Pre-series version
1.30	2010-JAN-07	Volume production version

Table 11.2: Hardware revision

12 References

[TMC262]	TMC262 Datasheet
[TMCL-IDE]	TMCL-IDE User Guide
[QSH8618]	QSH8618 Manual
[TMC262 / PD86-1180 TMCL™]	TMC262 and PD86-1180 TMCL™ Firmware Manual

Please refer to www.trinamic.com.