

## Technical Data Sheet

### 1.6x0.8mm Package Photodiode

#### PD83-01B/L458/TR8

#### Features

- Fast response time
- High photo sensitivity
- Small junction capacitance
- Pb free
- The product itself will remain within RoHS compliant version.

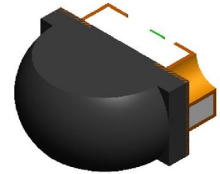

#### Descriptions

- PD83-01B/L458/TR8 is a high speed and high sensitive PIN photodiode in miniature flat top view lens SMD package and it is molded in a water clear plastic. The device is Spectrally matched to visible and infrared emitting diode.

#### Applications

- High speed photo detector

#### Device Selection Guide

LED Part No.	Chip	Lens Color
	Material	
PD83-01B/L458/TR8	Silicon	Black

### Package Dimensions

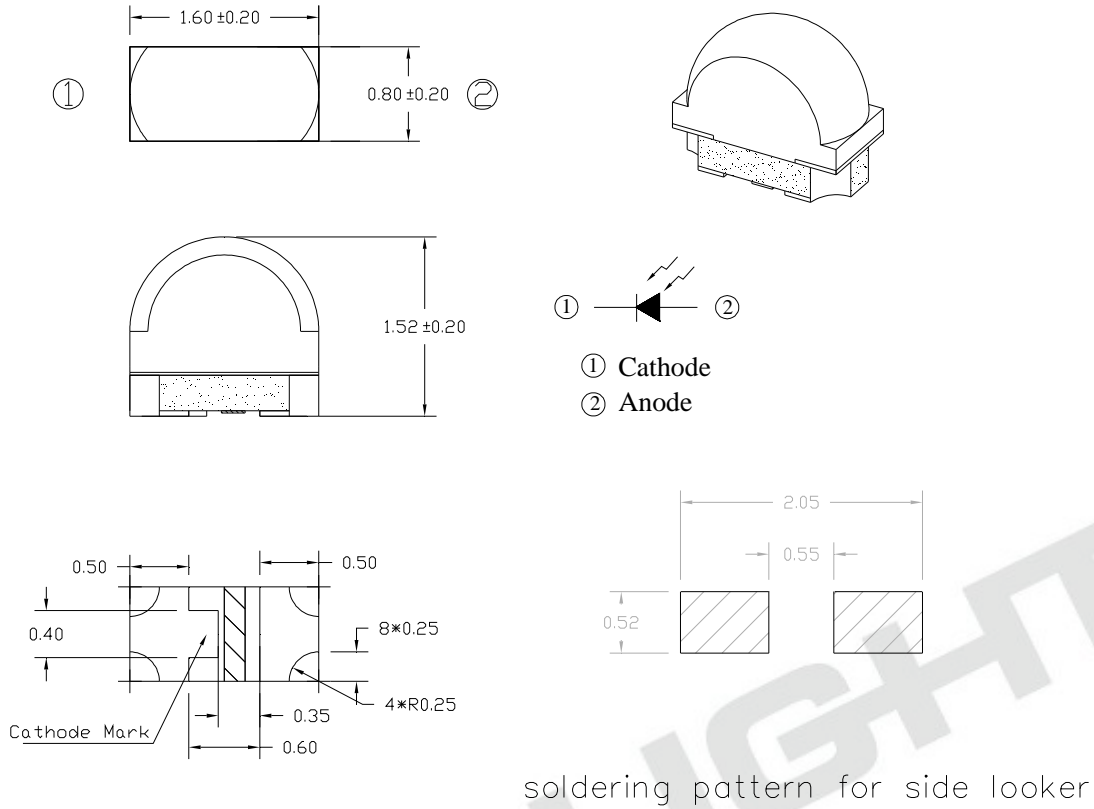

- Notes:** 1.All dimensions are in millimeters  
2.Tolerances unless dimensions  $\pm 0.1\text{mm}$

### Absolute Maximum Ratings ( $T_a=25^\circ\text{C}$ )

Parameter	Symbol	Rating	Units
Reverse Voltage	$V_R$	32	V
Operating Temperature	$T_{opr}$	-25 ~ +85	
Storage Temperature	$T_{stg}$	-40 ~ +100	
Soldering Temperature*1	$T_{sol}$	260	
Power Dissipation at(or below) 25 Free Air Temperature	$P_c$	150	mW

**Notes:** \*1:Soldering time 5 seconds.

### Electro-Optical Characteristics (Ta=25 )

Parameter	Symbol	Condition	Min	Typ	Max	Unit
Rang Of Spectral Bandwidth		10% of $\lambda_p$	760	---	1100	nm
Wavelength Of Peak Sensitivity	$\lambda_p$	---	---	940	---	nm
Short-Circuit Current	$I_{SC}$	$E_e=1mW/cm^2$ $\lambda_p=875nm$	---	2.0	---	$\mu A$
Reverse Light Current	$I_L$	$E_e=1mW/cm^2$ $\lambda_p=875nm$ $V_R=5V$	1.14	2.4	---	$\mu A$
Dark Reverse Current	$I_D$	$E_e=0mW/cm^2$ $V_R=10V$	---	---	10	nA
Reverse Breakdown Voltage	$B_{VR}$	$E_e=0mW/cm^2$ $I_R=100\mu A$	32	170	---	V
Total Capacitance	$C_t$	$E_e=0mW/cm^2$ $f=1MHz$ $V_R=3V$	---	2	---	pF
Rise Time	$t_r$	$V_R=5V$ $R_L=1000$	---	6	---	nS
Fall Time	$t_f$		---	6	---	
View Angle	2 1/2	$V_R=5V(X)$	---	90	---	deg
		$V_R=5V(Y)$		50		

### Typical Electro-Optical Characteristics Curves

Fig.1 Power Dissipation vs. Ambient Temperature

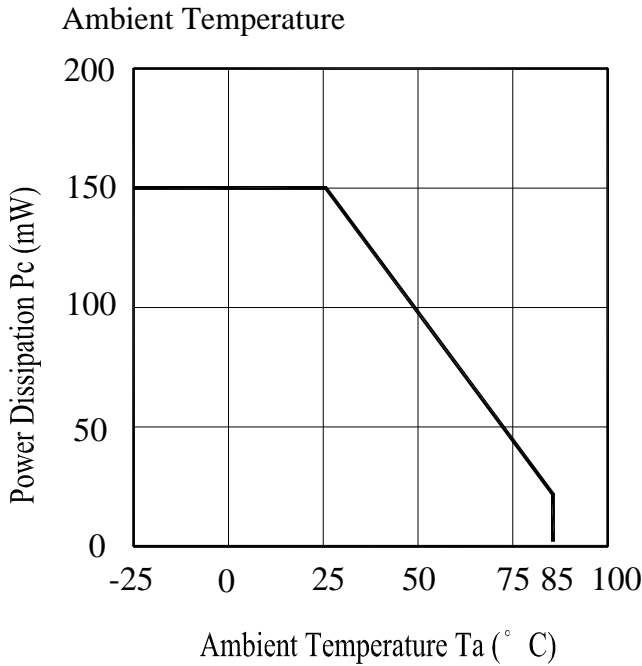

Fig.2 Spectral Sensitivity

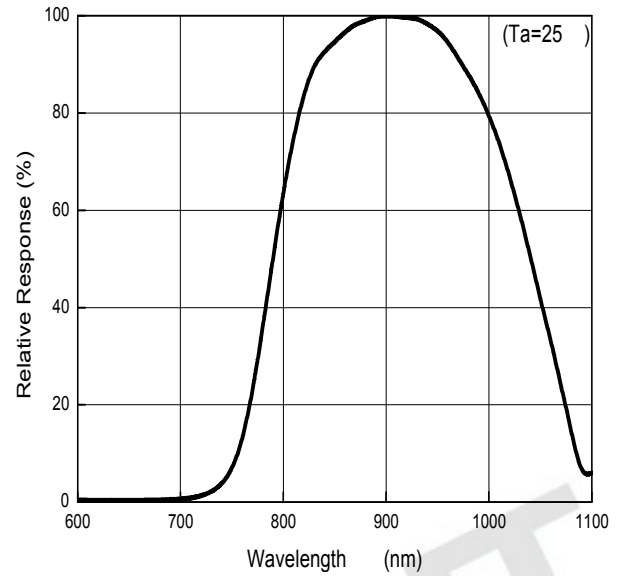

Fig.3 Dark Current vs. Ambient Temperature

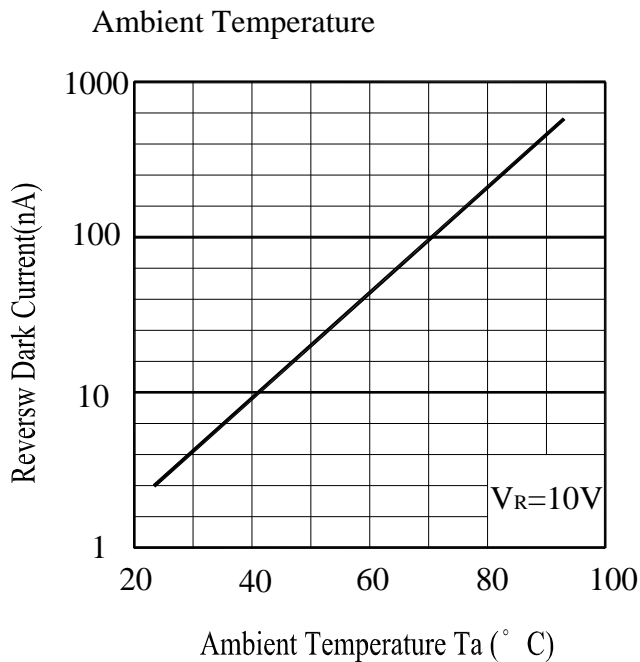
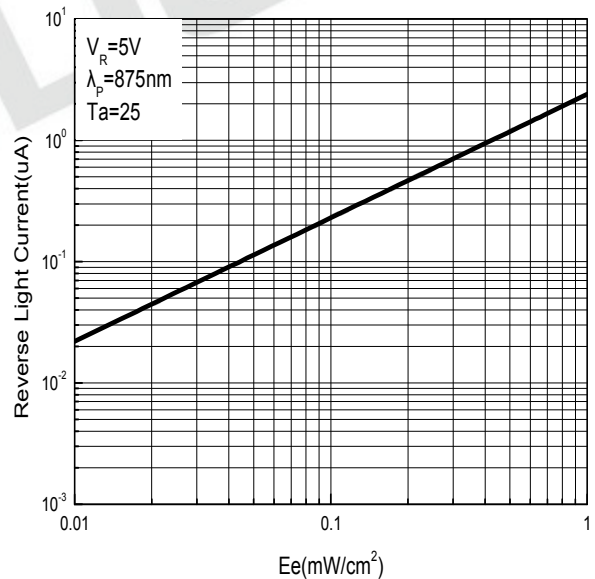

Fig.4 Reverse Light Current vs.  $E_e$



### Typical Electro-Optical Characteristics Curves

Fig.5 Relative Light Current vs.

Angular Displacement

(X position)

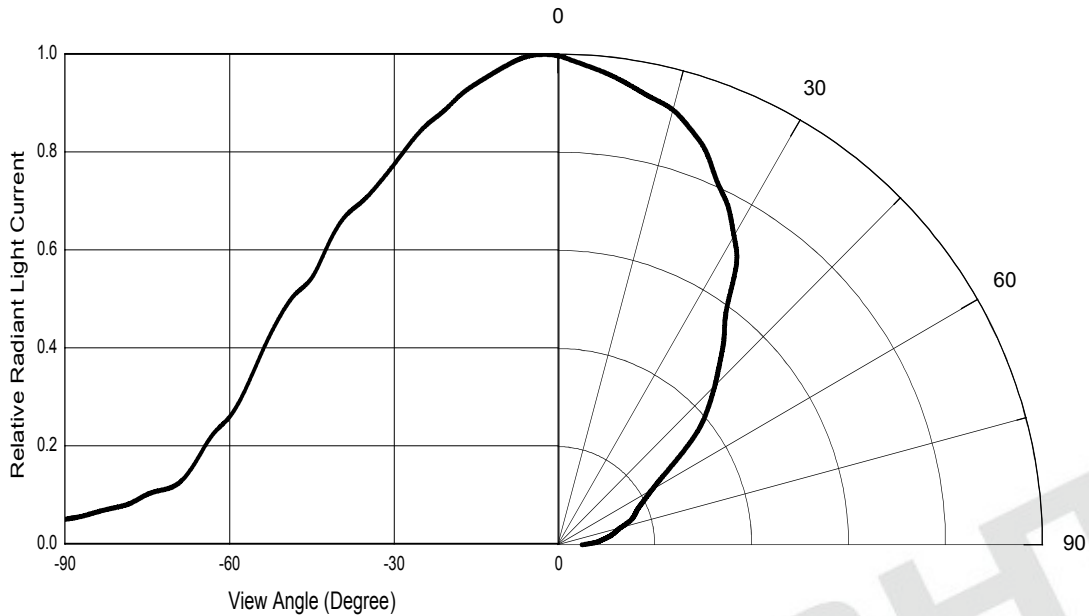

(Y position)

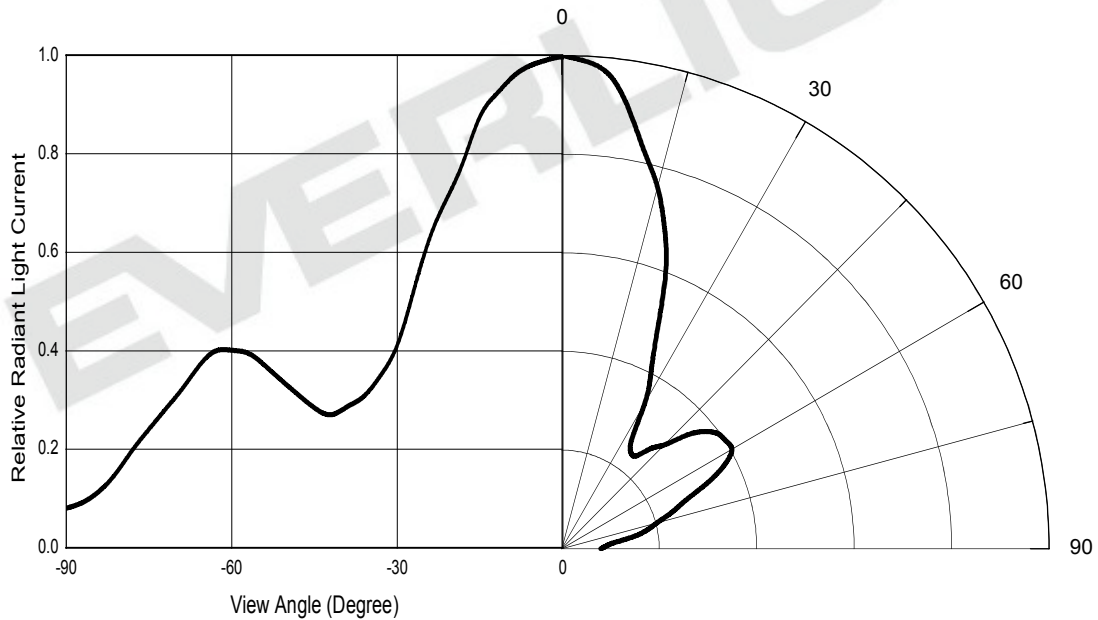

### Precautions For Use

#### 1. Over-current-proof

Customer must apply resistors for protection , otherwise slight voltage shift will cause big current change ( Burn out will happen ).

#### 2. Storage

2.1 Do not open moisture proof bag before the products are ready to use.

2.2 Shelf life in sealed bag from the bag seal date: 12 months at  $< 40^{\circ}\text{C}$  and  $< 90\% \text{ RH}$ .

2.3 After opening the package, the LEDs must be kept at  $\leq 30^{\circ}\text{C}$  and  $\leq 60\% \text{ RH}$ , and used within a year.

2.4 If the moisture absorbent material (silica gel) has faded away or the LEDs have exceeded the storage time. Baking treatment is required, refer to IPC/JEDEC J-STD-033 for bake procedure or recommend the conditions :  $60\pm 5^{\circ}\text{C}$  for 48 hours.

#### 3. Soldering Condition

##### 3.1 Pb-free solder temperature profile

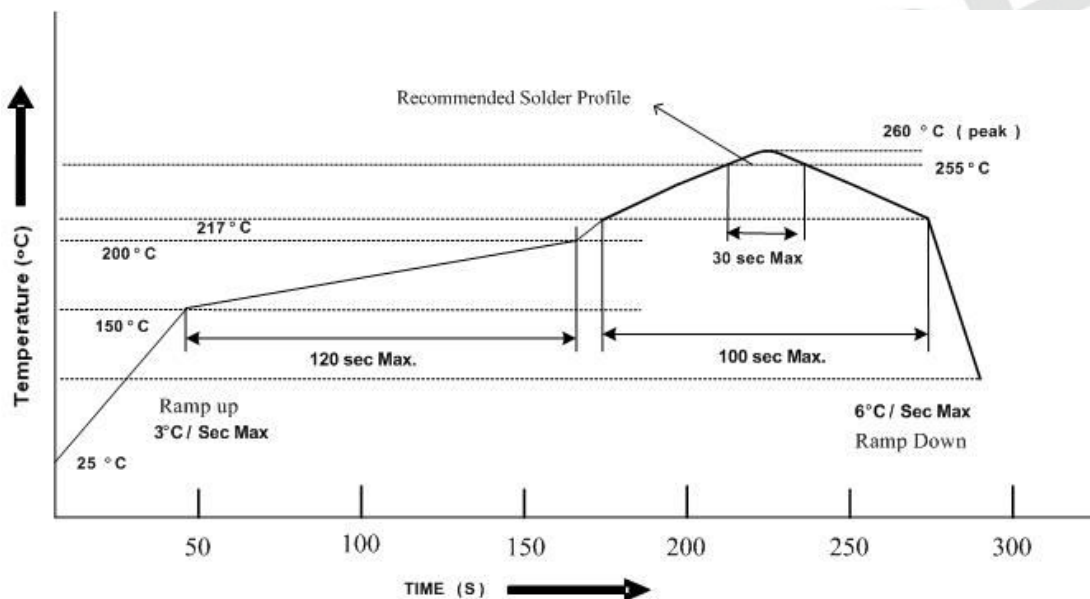

3.2 Reflow soldering should not be done more than two times.

3.3 When soldering, do not put stress on the LEDs during heating.

3.4 After soldering, do not warp the circuit board.

### 4.Soldering Iron

Each terminal is to go to the tip of soldering iron temperature less than 350 for 3 seconds within once in less than the soldering iron capacity 25W. Leave two seconds and more intervals, and do soldering of each terminal. Be careful because the damage of the product is often started at the time of the hand solder.

### 5.Repairing

Repair should not be done after the LEDs have been soldered. When repairing is unavoidable, a double-head soldering iron should be used (as below figure). It should be confirmed beforehand whether the characteristics of the LEDs will or will not be damaged by repairing.

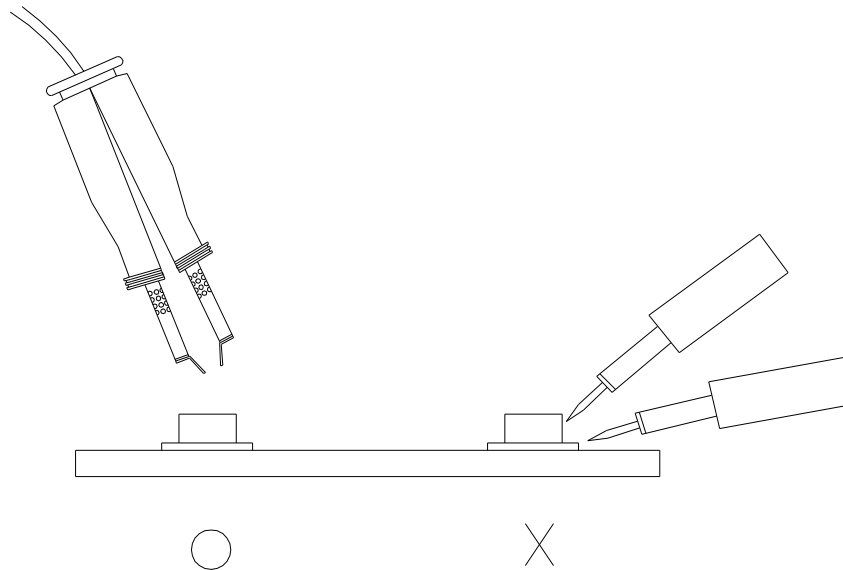

### Package Dimensions

#### 1. Reel Dimensions

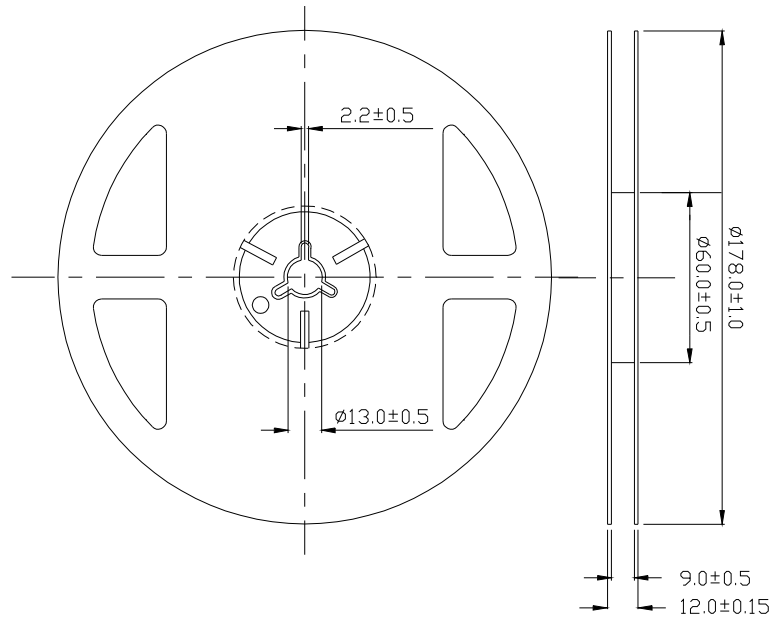

**Note:** The tolerances unless mentioned is  $\pm 0.1$ mm ,Unit = mm

#### 2. Carrier Tape Dimensions:(Quantity: 2000pcs/reel)

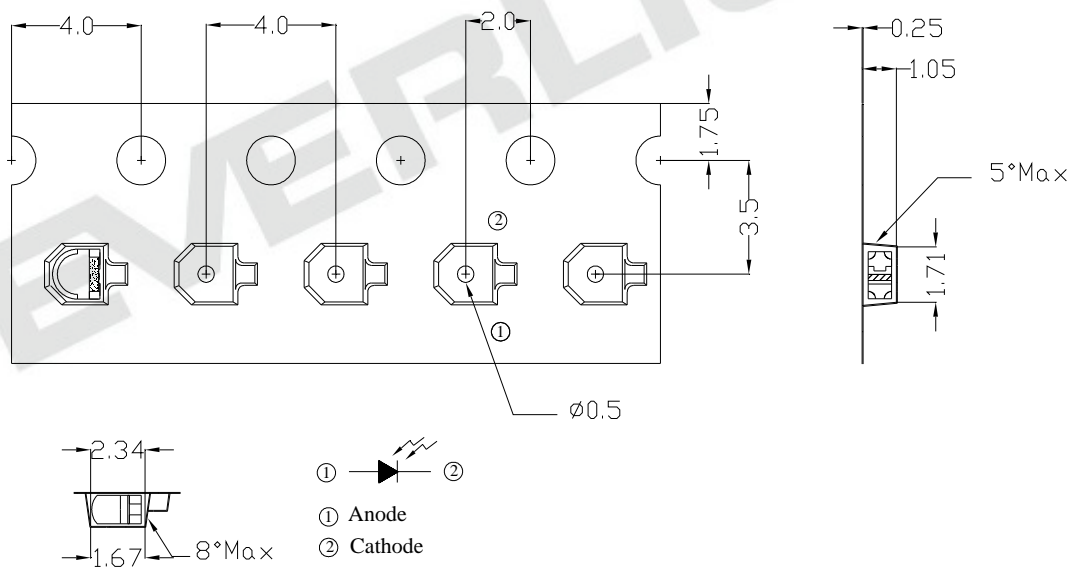

**Note:** The tolerances unless mentioned is  $\pm 0.1$ mm ,Unit = mm



### Packing Procedure

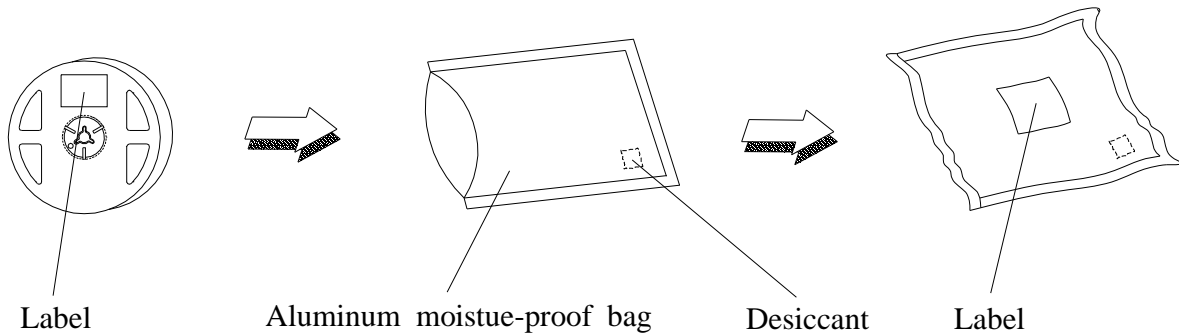

### Label Form Specification

	<b>EVERLIGHT</b>	
CPN : P/N : XXXXXXXXXXXXX XXXXXXXXXXXX		<b>RoHS</b>
QTY : XXX 	CAT : XXX HUE : XXX REF : XXX	
LOT NO : XXXXXXXXX 		
Reference : XXXXXXXXX 		

CPN: Customer's Production Number  
P/N : Production Number  
QTY: Packing Quantity  
CAT: Ranks  
HUE: Peak Wavelength  
REF: Reference  
LOT No: Lot Number  
MADE IN TAIWAN: Production Place

### Notes

1. Above specification may be changed without notice. EVERLIGHT will reserve authority on material change for above specification.
2. When using this product, please observe the absolute maximum ratings and the instructions for using outlined in these specification sheets. EVERLIGHT assumes no responsibility for any damage resulting from use of the product which does not comply with the absolute maximum ratings and the instructions included in these specification sheets.
3. These specification sheets include materials protected under copyright of EVERLIGHT corporation. Please don't reproduce or cause anyone to reproduce them without EVERLIGHT's consent.

**EVERLIGHT ELECTRONICS CO., LTD.**  
Office: No 6-8, Zhonghua Rd., Shulin Dist.,  
New Taipei City 23860, Taiwan, R.O.C

Tel: 886-2-2685-6688  
Fax: 886-2-2685-6897  
<http://www.everlight.com>