

Flashing Sounders PATROL series 110/120 dB(A) / 10/15 J PA X 10-10 / PA X 10-15 / PA X 20-10 / PA X 20-15



PATROL - the new generation of sounder/flashing light combinations. Three dimensional innovation;

- safe; an incorrect installation is virtually impossible
- easy; significantly shorter assembly and installation times
- economical; extremely high efficiency and good penetration of acoustical obstacles significantly reduce the required number of sounders
- pre-wired sounder and light ex works
- corresponding light intensity available for every sound pressure level

PA X 10 	PA X 20 				
Acoustic range	Acoustic range	Protection system	Operating temperature	Acoustic penetration	

Electrical data		PA X 10					
Rated voltage		230 V AC	115 V AC	24 V AC	48 V DC	24 V DC	12 V DC
Rated frequency		50 / 60 Hz	50 / 60 Hz	50 / 60 Hz			
Operating range		187 – 255 V	90 – 135 V	18 – 30 V	40 – 60 V	18 – 30 V	12 – 15 V
Nominal current consumption ¹	10 J	160 – 215 mA	260 – 345 mA	1 650 – 2 300 mA	360 – 490 mA	665 – 935 mA	1 335 – 1 685 mA
	15 J	210 – 265 mA	360 – 445 mA	1 650 – 2 300 mA	420 – 540 mA	765 – 1 035 mA	1 535 – 1 885 mA
Electrical data		PA X 20					
Rated voltage		230 V AC	115 V AC	24 V AC	48 V DC	24 V DC	12 V DC
Rated frequency		50 / 60 Hz	50 / 60 Hz	50 / 60 Hz			
Operating range		187 – 255 V	90 – 135 V	18 – 30 V	40 – 60 V	18 – 30 V	12 – 15 V
Nominal current consumption ¹	10 J	215 – 335 mA	340 – 560 mA	1 900 – 3 200 mA	495 – 800 mA	845 – 1 430 mA	1 220 – 1 690 mA
	15 J	165 – 385 mA	440 – 660 mA	1 900 – 3 200 mA	545 – 850 mA	945 – 1 540 mA	1 520 – 1 890 mA

¹ power consumption dependent on operating voltage

Mechanical data	PA X 10-10	PA X 10-15	PA X 20-10	PA X 20-15
Sound pressure level	110 dB (A)		120 dB (A)	
Sound level reduction	max. - 12 dB via potentiometer			
Alarm tones	80 (see tone table page 172/173)			
Flash energy	10 J	15 J	10 J	15 J
Flash rate	1 Hz = 60 flashes/min.			
Light intensity (DIN 5037) ¹	129 cd	190 cd	129 cd	190 cd
Operating temperature	- 40 °C ... + 55 °C			
Storage temperature	- 40 °C ... + 70 °C			
Relative humidity	90%			
Protection system according to EN 60529	IP 66			
Protection class	II			
Duty cycle	100%			
Service life of the flash tube	light emission still 70% after 8 000 000 flashes			
Material	sounder	PC / ABS blend		
	lens flashing light	polycarbonate (PC)		
Colour	housing	similar to RAL 3000 (flame red) / RAL 7035 (light grey) / RAL 9003 (signal white)		
	lens flashing light	clear, white, yellow, amber, red, green, blue		
Cable entry	4 x M20 knock-outs on side, 1 knock-out on back			
Integrated seal with cable entry	6 – 13 mm (feed-through grommet)			
Connecting terminals	2.5 mm ² fine wire with cable end sleeve, AWG 16			
Weight	AC	2 133 g	2 163 g	2 268 g
	DC	2 056 g	2 086 g	2 191 g

¹ with a clear lens

Dimensions

PA X 10-10 / PA X 10-15

PA X 20-10 / PA X 20-15

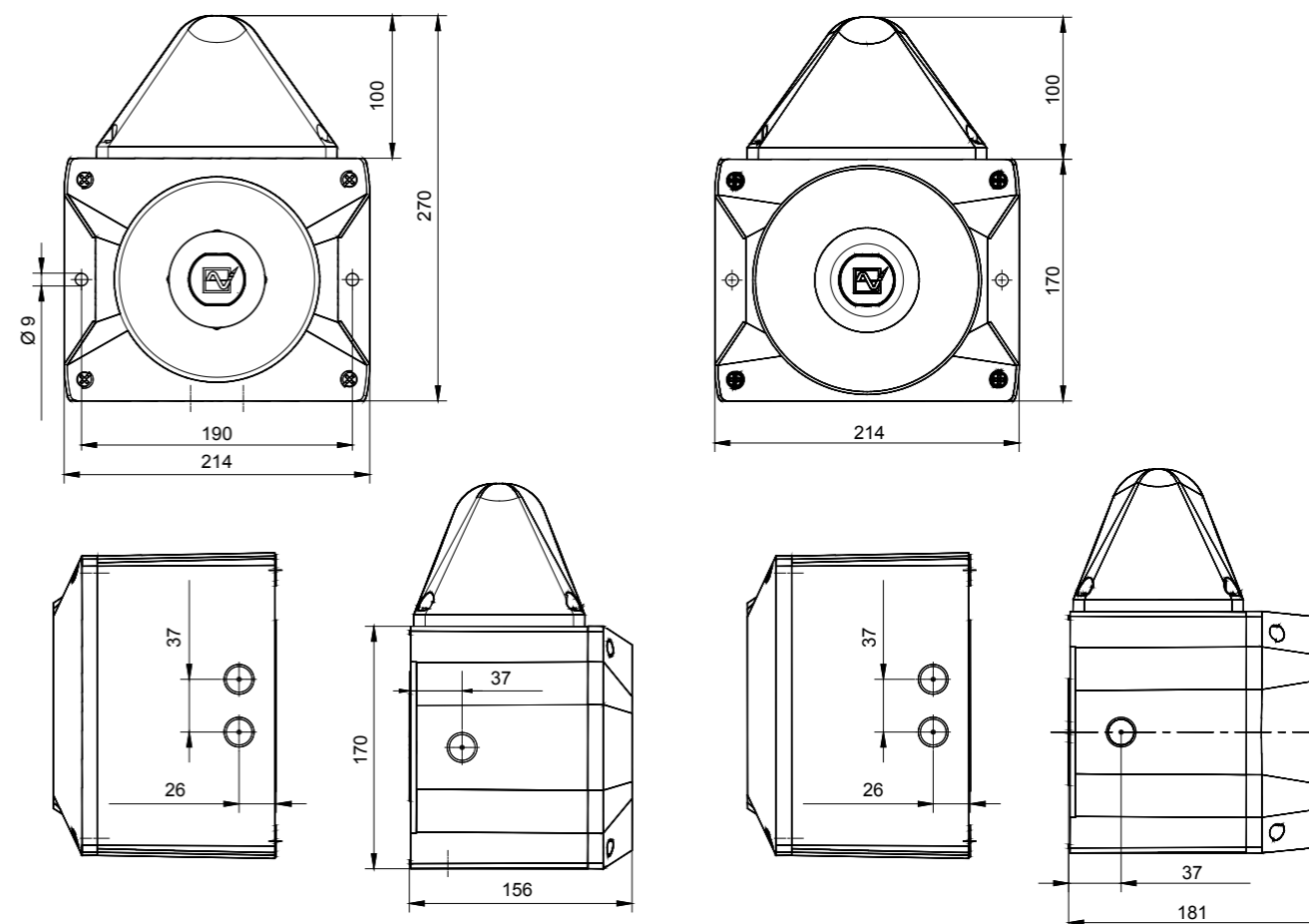

Ordering details

Article numbers		PA X 10-10			PA X 20-15		
Version	Rated voltage	230 V AC	115 V AC	24 V DC	230 V AC	115 V AC	24 V DC
yellow lens	housing red	233 61 10 3 000	233 61 15 3 000	233 61 80 3 000	233 72 10 3 000	233 72 15 3 000	233 72 80 3 000
amber lens	housing red	233 61 10 4 000	233 61 15 4 000	233 61 80 4 000	233 72 10 4 000	233 72 15 4 000	233 72 80 4 000
red lens	housing red	233 61 10 5 000	233 61 15 5 000	233 61 80 5 000	233 72 10 5 000	233 72 15 5 000	233 72 80 5 000
yellow lens	housing grey	233 61 10 3 055	233 61 15 3 055	233 61 80 3 055	233 72 10 3 055	233 72 15 3 055	233 72 80 3 055
amber lens	housing grey	233 61 10 4 055	233 61 15 4 055	233 61 80 4 055	233 72 10 4 055	233 72 15 4 055	233 72 80 4 055
red lens	housing grey	233 61 10 5 055	233 61 15 5 055	233 61 80 5 055	233 72 10 5 055	233 72 15 5 055	233 72 80 5 055

Article numbers for other voltages and versions on request

Options / Accessories



Enclo-
sure
fitting

Surface
gasket

Tamper-
proof
sealing



SSM
(only for 24 V DC)

See page 173 for further information

Conformity to standards

The acoustic parameters conform to the European standard DIN EN ISO 7731;
“Ergonomic – alarm signals for public areas and workplaces – acoustic alarm signals“.
 The requirement for an acoustic alarm signal can be found in the harmonised standards:
 EN 60204-1 Electrical equipment of machines
 EN 60825-1 Radiation safety of laser devices, identical to IEC 825 and DIN-VDE 0837

Tone table PA X 1 / PA X 5 / PA X 10 / PA X 20

Basic tone no.	Description	Basic tone no.	Description
1	no tone	69	Continuous tone
2	Sawtooth, DIN tone 33404-3 Germany (emergency signal), PFEER PTAP	71	Continuous tone
9	Slow whoop, fire alarm, UK BS5839-1	77	Interrupted tone
11	Interrupted tone (fast)	82	Interrupted tone, PFEER (general alarm), UK BS5839-1 (back-up alarm)
13	Interrupted tone	83	Interrupted tone, PFEER (general alarm)
15	Slow whoop, evacuation alarm Netherlands NEN 2575	88	Interrupted tone
16	Slow whoop, Australian evacuation alarm AS2220	90	Interrupted tone
18	Slow whoop, NFPA	91	Interrupted tone
22	Pulsating tone, Australian alert AS1670, ISO8201	92	Interrupted tone
23	Siren	93	Interrupted tone (fast), horn
24	Siren	97	Interrupted tone
25	Siren	98	Interrupted tone, Sweden SS031711 (emergency signal)
26	Pulsating tone, industrial alarm Germany	100	Interrupted tone, industrial alarm (Germany)
27	Sweeping	101	Interrupted tone, Sweden SS031711 (important message (pres-mess))
29	Sweeping (fast)	102	Interrupted tone, Sweden SS031711 (local warning)
30	Sweeping	103	Interrupted tone, Sweden SS031711 (air raid warning)
31	Sweeping, France NFC48-265	104	Interrupted tone, Sweden SS031711 (emergency signal)
33	Sweeping (medium), UK BS5839-1	107	Interrupted tone, Germany KTA3901 (evacuation alarm)
34	Sweeping (fast)	109	Interrupted tone, Australia AS2220, AS1610, AS1670
35	Sweeping (fast), UK BS5839-1	110	Interrupted tone, (fast variable), bell
36	Sweeping	111	Interrupted tone, ISO8201 (emergency evacuation signal), USA (evacuation alarm)
43	Sweeping	112	Interrupted tone, ISO8201 (emergency evacuation signal)
44	Sweeping, IMO 3d, Germany KTA3901 evacuation alarm	113	Interrupted tone, ISO8201 (emergency evacuation signal), Sweeping
45	Sweeping	115	Interrupted tone, IMO (telephone call)
46	Sweeping, general alarm Finland	116	Interrupted tone, IMO (leave ship)
52	Continuous tone	117	Interrupted tone, IMO SOLAS III/50 + SOLAS III/6.4 (general alarm)
53	Continuous tone	122	Alternating tone
54	Continuous tone, Finland (all-clear signal)	123	Alternating tone
55	Continuous tone, PFEER gasalarm	124	Alternating tone, Singapore
56	Continuous tone	125	Alternating tone
57	Continuous tone, UK BS5839-1	128	Alternating tone
59	Continuous tone	130	Alternating tone, UK BS5839-1 (fire alarm)
60	Continuous tone	131	Alternating tone, UK BS5839-1 (fire alarm, railway crossing)
61	Continuous tone	135	Alternating tone, UK BS5839-1 (fire alarm, increased urgency - railway crossing)
63	Continuous tone	142	Alternating tone
65	Continuous tone, Sweden SS031711 (all-clear signal)		
66	Continuous tone		
67	Continuous tone, Germany KTA3901 (all-clear signal)		
68	Continuous tone		

Tone table PA X 1 / PA X 5 / PA X 10 / PA X 20

Basic tone no.	Description	Basic tone no.	Description
143	Alternating tone, industrial alarm (Germany)	147	Alternating tone, Sweden SS031711
144	Alternating tone	148	Alternating tone, Sweden SS031711
146	Alternating tone, France NFS 32-001 (fire alarm)	152	Alternating tone (two tone chime)

Control of the tones

Tone selection switch/DIP-Switch (setting of basic tone)						External tone selection			Tone selection switch/DIP-Switch (setting of basic tone)						External tone selection				
1	2	3	4	5	6	Basic tone no.	C1	C2	C1+C2	1	2	3	4	5	6	Basic tone no.	C1	C2	C1+C2
						1	2	88	57							71	131	52	93
						2*	128	112	57							77	61	52	122
	ON					2	26	100	93		ON					82	131	52	83
ON	ON					2	61	131	112		ON	ON				83	56	2	82
		ON				9	57	11	82			ON				88	2	57	128
ON		ON				15	131	52	112		ON	ON				90	131	52	125
	ON	ON				16	109	52	56			ON	ON			91	30	52	110
ON	ON	ON				18	111	57	68		ON	ON	ON			92	33	52	57
			ON			22	16	109	68				ON			93	2	128	57
ON		ON				23	131	52	112		ON		ON			97	2	63	93
	ON	ON				24	131	52	131			ON	ON			100	131	52	125
ON	ON		ON			25	131	52	92		ON	ON	ON			101	98	102	65
		ON	ON			26	2	100	93				ON	ON		103	131	65	147
ON		ON	ON			27	123	52	92		ON	ON	ON			104	103	65	101
	ON	ON				29	35	52	61			ON	ON	ON		109	16	52	22
ON	ON	ON				30	27	52	77		ON	ON	ON	ON		110	131	61	91
				ON		31	131	52	57					ON	ON	112	2	57	128
ON			ON			33	30	52	35		ON			ON	ON	113	52	123	104
	ON		ON			34	35	52	93			ON		ON	ON	115	117	116	44
ON	ON		ON			35	27	52	110		ON	ON		ON	ON	116	117	93	125
		ON	ON			36	146	67	57				ON	ON	ON	117	93	116	125
ON		ON	ON			43	131	52	91		ON		ON	ON		123	27	52	77
	ON	ON		ON		45	2	57	93			ON	ON			124	53	83	2
ON	ON	ON		ON		52	15	65	82		ON	ON	ON			130	2	107	67
			ON	ON		54	46	54	131				ON	ON	ON	131	2	112	57
ON			ON	ON		55	131	52	128		ON		ON	ON	ON	135	16	56	109
	ON		ON	ON		56	82	35	33			ON	ON	ON		142	2	54	88
ON	ON		ON	ON		59	143	59	101		ON	ON	ON	ON		143	59	93	33
			ON	ON		60	131	52	125				ON	ON	ON	144	110	61	2
ON		ON	ON	ON		65	131	52	93		ON	ON	ON	ON		146	31	67	57
	ON	ON	ON	ON		66	110	52	107				ON	ON	ON	148	131	52	92
ON	ON	ON	ON	ON		69	131	52	110		ON	ON	ON	ON	ON	152	110	61	13

* factory setting

Accessories

Ordering details			
Article numbers	PA X 1-05	PA X 5-05	PA 10 X / PA 20 X
Enclosure fitting	For connection (daisy-chaining) of several sounders of the PATROL series		
Surface gasket	Sealing of the sounder installation surface when, e.g. cable entry is executed from the back.		
Tamper-proof sealing (pack of 4)	Anti-tamper sealing for fasteners of the PATROL devices after installation in order to prevent manipulation of the devices.		
	283 00 00 0 004	283 00 00 0 005	283 00 00 0 006
	283 00 00 0 002		