



Switch-Disconnectors Flush mounting



Powering Business Worldwide™

Part no. P1-25/E

Article no. 038724

Program

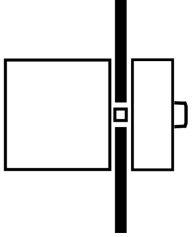
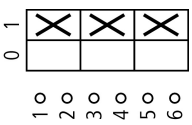
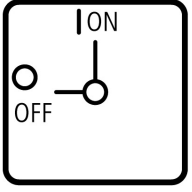
Range			Load current switches
Basic function			ON-OFF switches
Part group reference (e.g. DIL)			P1
Design			Flush mounting
			
Protection type			Front IP65
Emergency stop			without emergency switching off/emergency stop function
			with black thumb grip and front plate
Locking facility			Not lockable
			without auxiliary contacts
Contact sequence			 1 0 2 0 3 0 4 0 5 0 6 0
Front plate no.			 FS 908
Main conducting paths			
No. of poles		M	3
Auxiliary contacts		N/O	0
		B	0
Max. motor rating			
AC-23A			
400/415 V 50-60 Hz	P	kW	13
Rated uninterrupted current	I_u	A	25

Approbationen

UL approval	Yes
CSA approval	Yes
Product Standards	UL 508; CSA-C22.2 No. 14-05; IEC/EN 60947-3; CE marking
UL File No.	E36332
UL CCN	NLRV
CSA File No.	12528
CSA Class No.	3211-05
NA Certification	UL listed, CSA certified
Suitable for	Branch circuits, suitable as motor disconnect
Degree of Protection	IEC: IP65; UL/CSA Type 3R, 12

General

Standards			IEC/EN 60947, VDE 0660, IEC/EN 60204, CSA, UL switch disconnectors according to IEC/EN 60947-3
-----------	--	--	--

Lifespan, mechanical	Operations	$\times 10^6$	0.3
Maximum operating frequency		Operations/h	90
Climatic proofing			Damp heat, constant, to IEC 60068-2-78; Damp heat, cyclical, to IEC 60068-2-30
Ambient temperature		°C	
Open		°C	- 25 - 50
Enclosed		°C	- 25 - 40
Mounting position			As required
Mechanical shock resistance to IEC 60068-2-27	Half-sinusoidal shock	g	> 15
		20 ms	

Contacts

Rated operational voltage	U_e	V AC	690
Rated impulse withstand voltage	U_{imp}	V AC	6000
Overvoltage category/pollution degree			III/3
Rated uninterrupted current	I_u	A	
open	I_u	A	25
Enclosed	I_u	A	25
Load rating with intermittent operation, class 12			
AB 25 % DF		$\times I_e$	2
AB 40 % DF		$\times I_e$	1.6
AB 60 % DF		$\times I_e$	1.3
Short-circuit rating			
Fuse		A gG/gL	25
Rated short-time withstand current (1 s current)	I_{cw}	A_{rms}	640
Switching angles		°	90
Current heat loss per contact at I_e		W	1.1

Terminal capacities

Solid or stranded		mm ²	1 x (1.5 - 6) 2 x (1.5 - 6)
Flexible with ferrule to DIN 46228		mm ²	1 x (1 - 4) 2 x (1 - 4)
Terminal screw			M4
Tightening torque		Nm	1.6

Switching capacity

AC		$\times U_s$	
Rated making capacity $\cos \varphi = 0.35$		A	240
Rated breaking capacity, motor load switch $\cos \varphi = 0.35$		A	
230 V		A	190
400 V		A	150
500 V		A	170
690 V		A	150
Rated operational current 440 V load-break switch AC-21A	I_e	A	25
Rating, AC-3 motor load switch	P	kW	
220/230 V	P	kW	5.5
400 V	P	kW	7.5
500 V	P	kW	7.5
690 V	P	kW	7.5
AC-23A Motor load switches (main switches maintenance switches)	P	kW	
230 V	P	kW	7
400 V	P	kW	13
500 V	P	kW	11
690 V	P	kW	11

DC		x U _s	
DC-1, Load-break switches L/R = 1 ms			
Rated operational current	I _e	A	25
Voltage per contact pair in series		V	60
DC-23A, motor load switch L/R = 15 ms			
24 V			
Rated operational current	I _e	A	25
Contacts		Quantity	1
48 V			
Rated operational current	I _e	A	25
Contacts		Quantity	2
60 V			
Rated operational current	I _e	A	25
Contacts		Quantity	3
120 V			
Rated operational current	I _e	A	12
Contacts		Quantity	3

Notes

Notes Main switch characteristics to IEC/EN 60204; positive opening of contacts, operator element positively located on shaft
The rated uninterrupted current I_{ij} is stated at max. connected cross-section.
For terminal capacity solid, stranded and flexible:
Max. 2 cross-section sizes difference admissible when using 2 conductors.

Technical data according to ETIM 4.0

Number of auxiliary contacts as normally open contact			0
Number of auxiliary contacts as normally closed contact			0
Rated permanent current I _u		A	25
Number of poles			3
Conditioned rated short-circuit current I _q		kA	0
Degree of protection (IP), front side			IP65
Number of auxiliary contacts as change-over contact			0
Interlockable			No
Motor drive integrated			No
Connection type main current circuit			Screw connection
Version as emergency stop installation			No
Type of control element			Toggle
Version as main switch			No
Version as switch disconnecter compact			YES
Version as safety switch			No
Version as maintenance-/service switch			No
Rated operation power at AC-23, 400V		kWh	13
Rated operation power AC-3, 400 V		kWh	7.5
Suitable for ground mounting			No
Suitable for front mounting			YES
Suitable for front mounting center			No
Suitable for distribution board installation			No
Suitable for intermediate mounting			No
Max. rated operation voltage U _e AC		V	690
Motor drive optional			No
Voltage release optional			No
Device construction			Built-in device fixed built-in technique

Characteristics

Form for ordering non-standard front plates

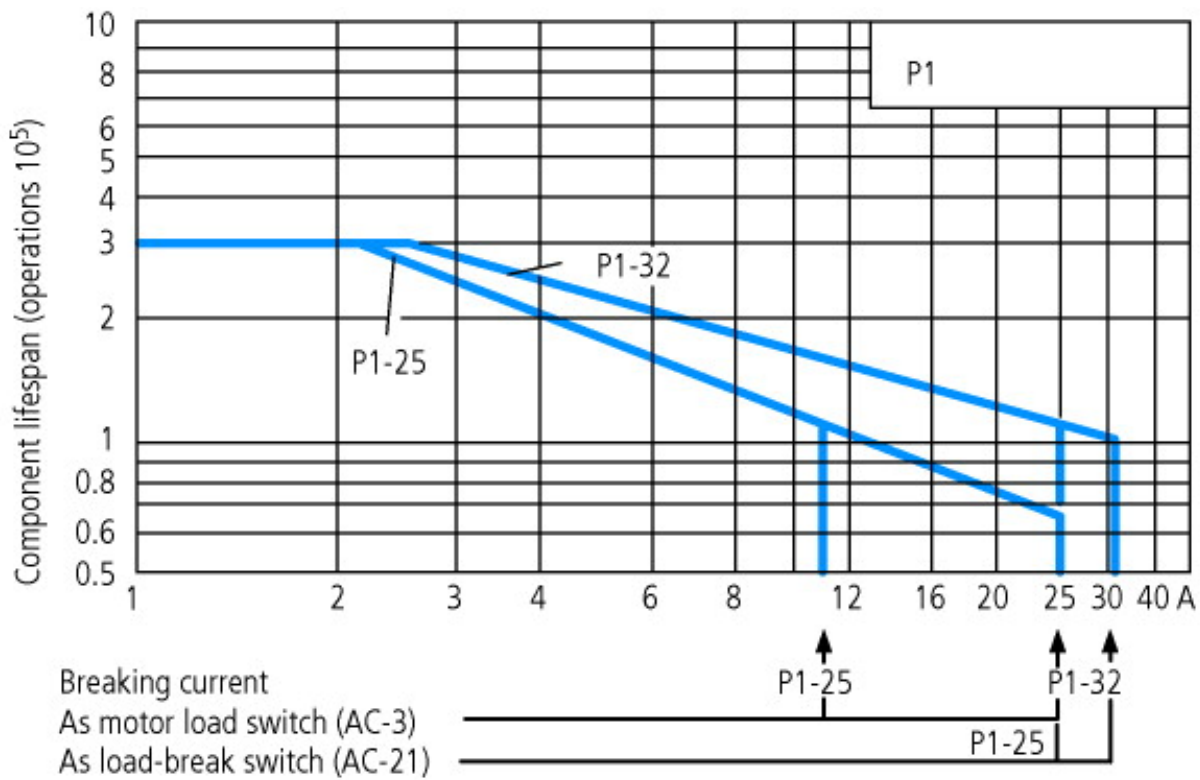

For utilisation category AC-4 (extreme load: 100 % inching, reversing or plugging)
 The blocked rotor current of the motor should not exceed the rated current of the switch for AC-21A to ensure a reasonable device lifespan.

Dimensions

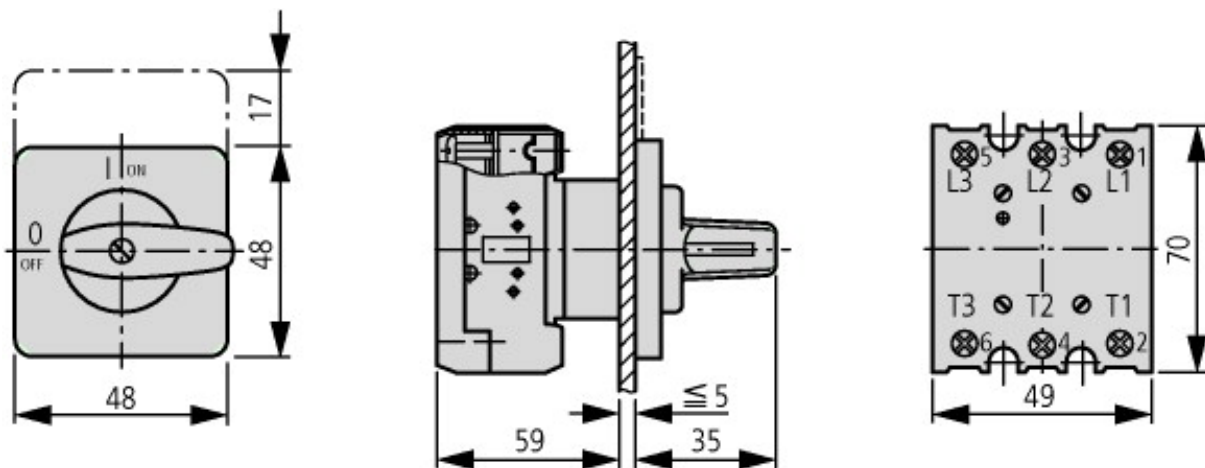

Drilling dimensions door

Additional product information (links)

AWA1150-1890 (IL03802003Z) Switch-Disconnectors P1 for flush mounting	ftp://ftp.moeller.net/DOCUMENTATION/AWA_INSTRUCTIONS/18900808.pdf
Engineering	
Technical overview	ftp://ftp.moeller.net/DOCUMENTATION/PDF/GB/Ovt_t_p_Leistung_G.pdf
Key to part numbers, modular system	ftp://ftp.moeller.net/DOCUMENTATION/PDF/GB/Ovt_t_p_Typenschluessel_G.pdf
Ordering of non-standard switches	ftp://ftp.moeller.net/DOCUMENTATION/PDF/GB/Bestellformulare_de.pdf