

REV.	DATE	FILE No.
1.0	2011-5-3	SC88-1M

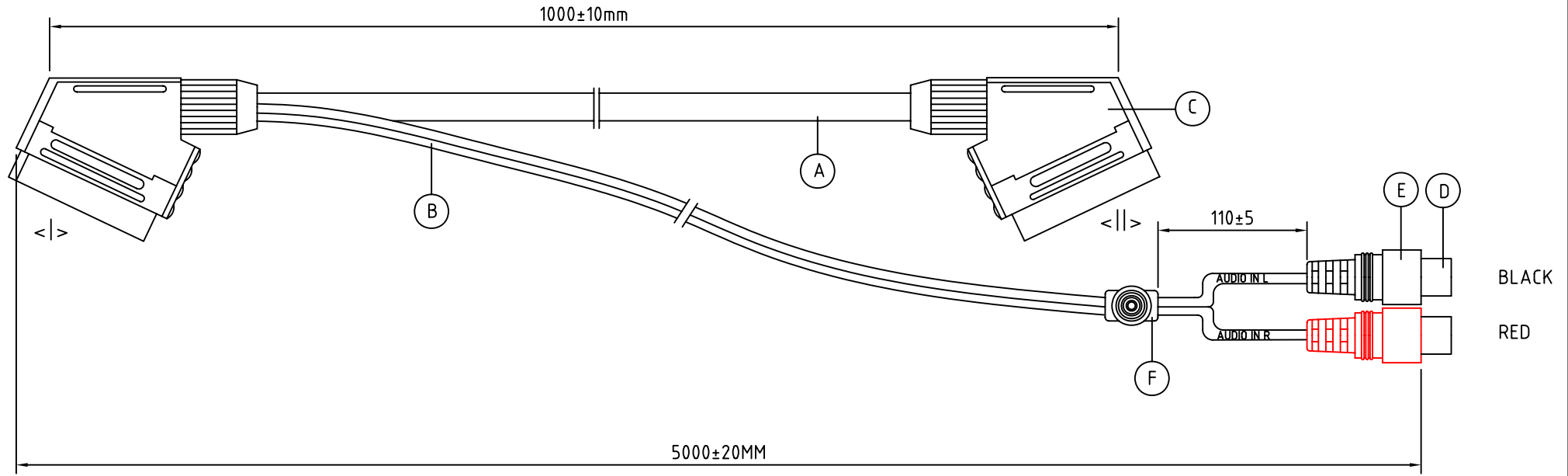

WIRING DIAGRAM

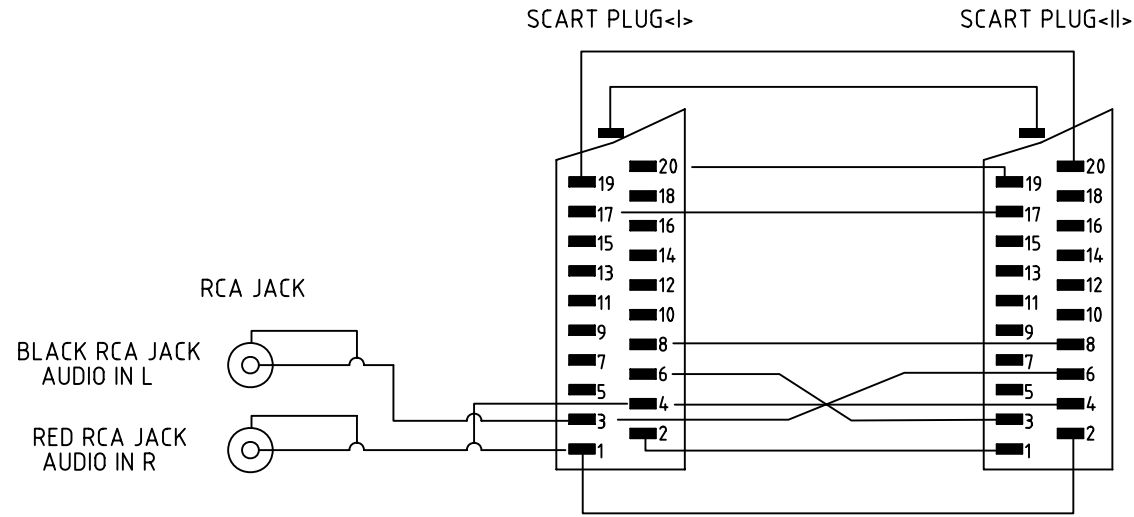

SPECIFICATION:

ITEM	PART NAME	MATERIAL	COLOR	QTY.
A	VC3C9(0.16/7X9C+0.16/7T+AL)X1C O.D.7.5	PVC	BLACK	1M
B	CABLE(0.12/10+0.12/12)X2F #2.6X5.2MM	PVC	BLACK	5M
C	21P.SCART PLUG	ABS/P.B.	BK/NI	2SET.
D	Y/A001 RCA JACK	P.B.	NICKEL	2
E	MODEL TY-048 TYPE	PVC	RD/BK	2
F	STOPPER MODEL TY-046 TYPE	PVC	BLACK	1

NOTE:ALL MATERIALS ARE COMPLIANT TO "RoHS".

CUSTOMER: JESS LINK		Maxxtro®		
CUST. P/N: 105058				
S/O:	S/N:	PART No.: SC88-1M/BK		
DRAWING No.	SC-088-05	PART NAME: 21P.SCART PLUG TO PLUG+2XRCA JACK		
DRAWN BY	Lingqi Meng	UNLESS OTHERWISE SPECIFIED, ALL DIMENSIONS ARE IN MM. TOLERANCE:DECIMAL .X ±0.1 .XX ±0.05 ANGLE ±1/2°		
CHECKED BY	Zhongjiao/Baifa			SHEET 1 OF 1
APPROVED BY	Chenhan			SCALE NO