

CN1

CN2

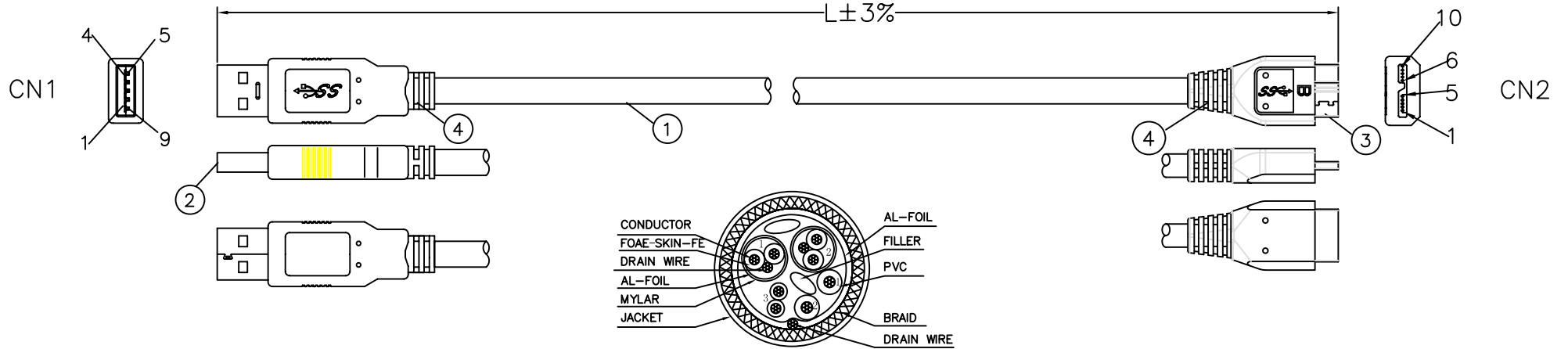

MATERIAL LIST:

NO.	PARTS NAME	SPECIFICATION DESCRIPTION
①	CABLE	2* ( 1P*28AWG+D+AL+MYLAR ) +1P*28AWG +2C*28AWG+AL+D+B(60%) OD:6.0±0.2mm COLOR:BLACK
②	USB 3.0 CONNECTOR	USB A MALE 9P INSULATOR BLUE SOLDER TYPE PIN GOLD PLATED NICKEL PLATED SHELL
③	USB 3.0 CONNECTOR	MICRO B MALE 10P INSULATOR BLACK SOLDER TYPE PIN GOLD PLATED NICKEL PLATED SHELL
④	MOLDING PVC	MOLDING PVC 063 45P COLOR:BLACK

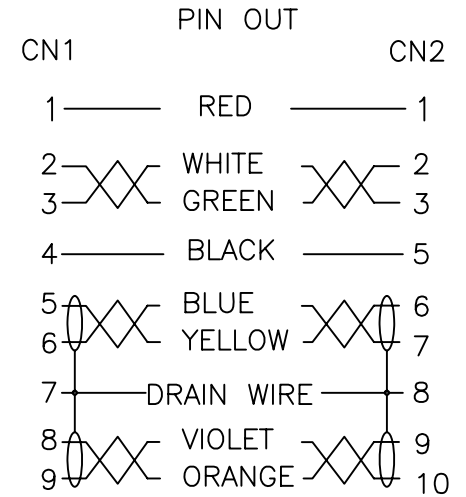
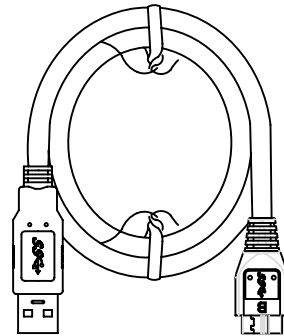

SHELL ——— BRAID ——— SHELL

Marking: Maxxtro AWM E200765 STYLE 2725 60°C 30V BYB Universal Serial Bus 3.0

ITEM NO	LENGTH	PVC COLOR	PACKING
104351	900±30mm	BLACK 063	ZB-M

ELECTRONIC TEST:

- A.OPEN/SHORT/INTERMITTENCE: 100%.
- B.HI-POT: 300V DC/sec
- C.INSULATION RESISTANCE: 20M ohm (MIN)
- D.CONDUCTIVE RESISTANCE: 2 ohm (MAX)

				<b>Maxxtro®</b>			
REMARK/NO	CHA.NO	SIGNATURE	DATE	SIGN		W.T	SCALE
DRAWN BY	Renzhi						
CHECKED BY							
AUDITED BY		APPROVED BY	zhangweidong				
CRAFT		DATE	2011.03.16	PAGE OF			ITEM NO. (SECTION SHEET)