

MATERIAL LIST:

NO.	PARTS NAME	SPECIFICATION DESCRIPTION
①	CABLE	UL20276 4*(1P*30AWG+AL+D+MYLAR)+1P*30AWG+3C*30AWG+AL+D+B (60%) OD:6.0±0.2mm COLOR:BLACK
②	DVI CONNECTOR	DVI 18+1 MALE INSULATOR BLACK SOLDER TYPE PIN GOLD PLATED 1u" GOLD PLATED SHELL
③	HDMI CONNECTOR	HDMI 19P MALE INSULATOR BLACK SOLDER TYPE PIN GOLD PLATED 1u" GOLD PLATED SHELL
④	SCREW	Ø4*47mm NICKEL PLATED
⑤	MOLDING PVC	MOLDING PVC 063 45P COLOR:BLACK
⑥	MOLDING PVC	MOLDING PVC 063 30P COLOR:BLACK

Marking: Maxxtro STANDARD HDMI® CABLE STYLE 20276 80°C 30V FT2

ITEM NO	LENGTH	PVC COLOR	PACKING
101295	2000±50mm	BLACK 0020	ZB-L

ELECTRONIC TEST:

- A.OPEN/SHORT/INTERMITTENCE: 100%.
- B.HI-POT: 300V DC/sec
- C.INSULATION RESISTANCE: 10M ohm (MIN)
- D.CONDUCTIVE RESISTANCE: 5ohm (MAX)

CONNECTION

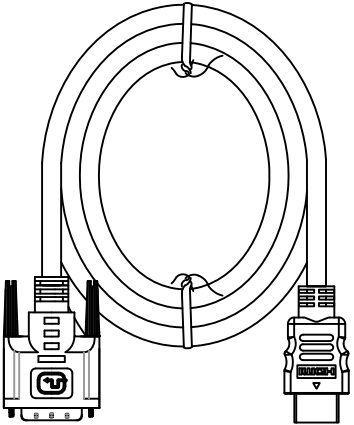
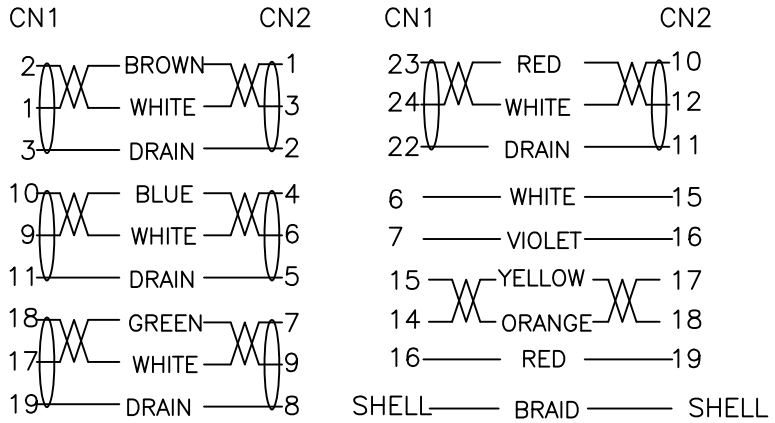

REMARK NO	CHA.NO	SIGNATURE	DATE	SIGN	W.T	SCALE
DRAWN BY	Renzhi					
CHECKED BY						
AUDITED BY		APPROVED BY	zhangweidong			
CRAFT		DATE	2011.01.26			
				PAGE	OF	