

Telescopic clip

Part no.

M22-TC

Article no.

216398



Powering Business Worldwide™

For equalization of the mounting depth of rear mounting devices in CI enclosures, and in cabinets with mounting depths from 115 - 155 mm. Steplessly adjustable, screw- and snap fixing (top-hat rail IEC/EN 60715).

maximum of 10 x M22-TC brackets per enclosure, five of which can hold stay-put actuators

Do not use in conjunction with emergency switching off actuators.

Program

Range			RMQ-Titan (drilling dimensions 22.5 mm)
Basic function			Accessories
Accessories			General accessories
Basic function accessories			Telescopic clip
Single unit/Complete unit			Single unit
			Steplessly adjustable, screw- and snap fixing (top-hat rail IEC/EN 60715). maximum of 10 x M22-TC brackets per enclosure, five of which can hold stay-put actuators Do not use in conjunction with emergency switching off actuators. Three contact/LED elements with base fixing Including centring adapter
Function			For equalization of the mounting depth of rear mounting devices in CI enclosures, and in cabinets with mounting depths of 115 - 155 mm
Front ring			Front ring: titanium
Connection to SmartWire-DT			no

Approbationen

UL approval	Yes
CSA approval	Yes
Product Standards	IEC/EN 60947-5; UL 508; CSA-C22.2 No. 14-05; CSA-C22.2 No. 94-91; CE marking
UL File No.	E29184
UL CCN	NKCR
CSA File No.	012528
CSA Class No.	3211-03
NA Certification	UL listed, CSA certified

Technical data according to ETIM 4.0

Type of mechanical accessory			-
Type of electrical accessory			-

CAD-Data

Product standards CAD data:

<http://eaton-moeller.partcommunity.com>

Dimensions

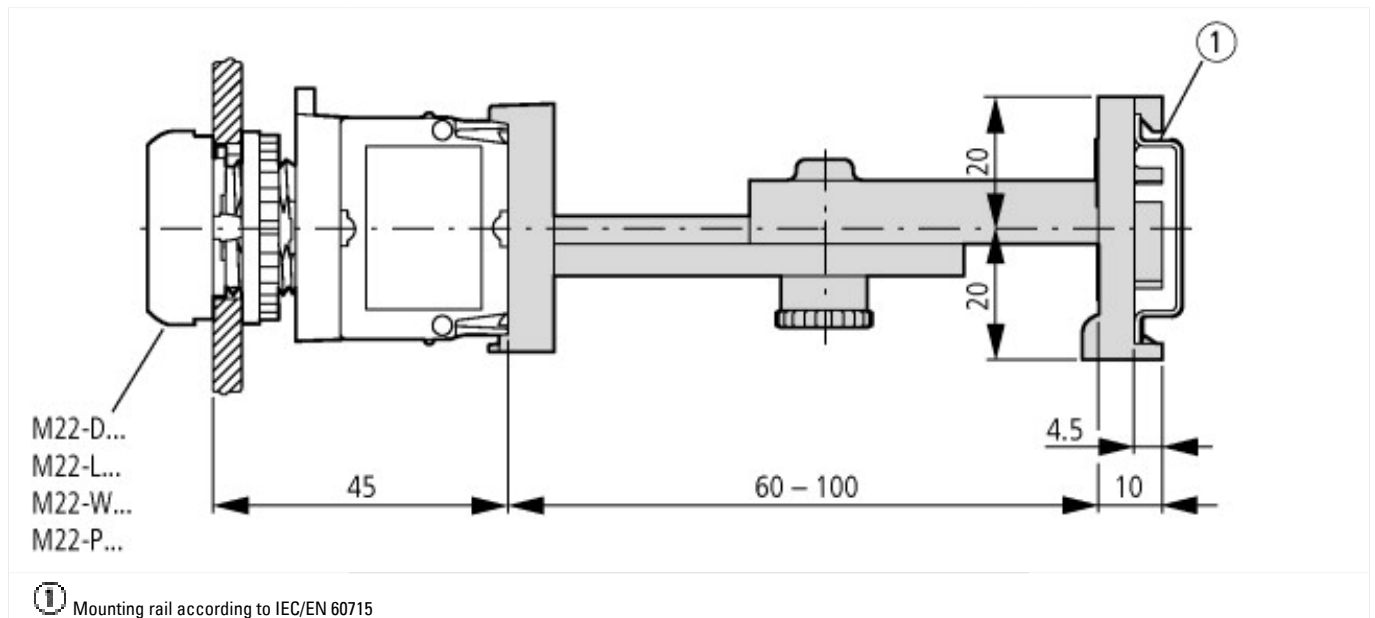

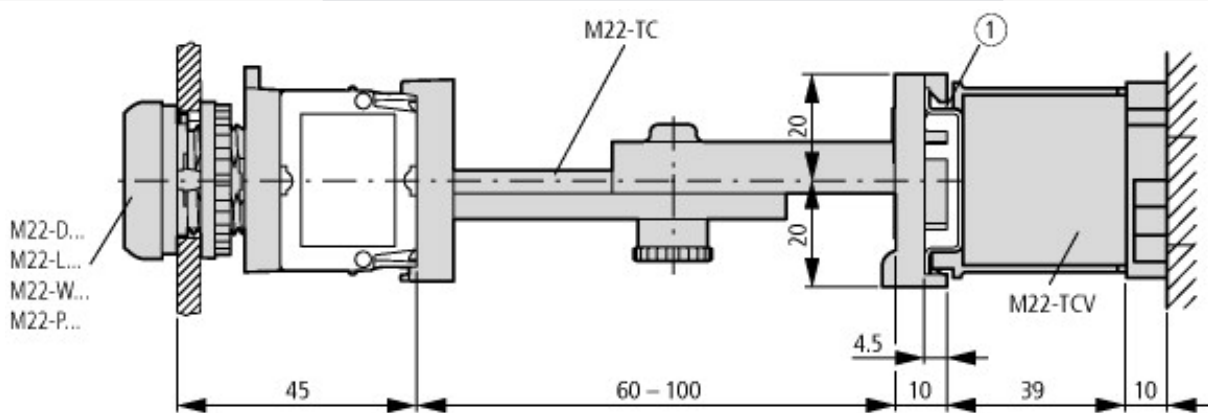
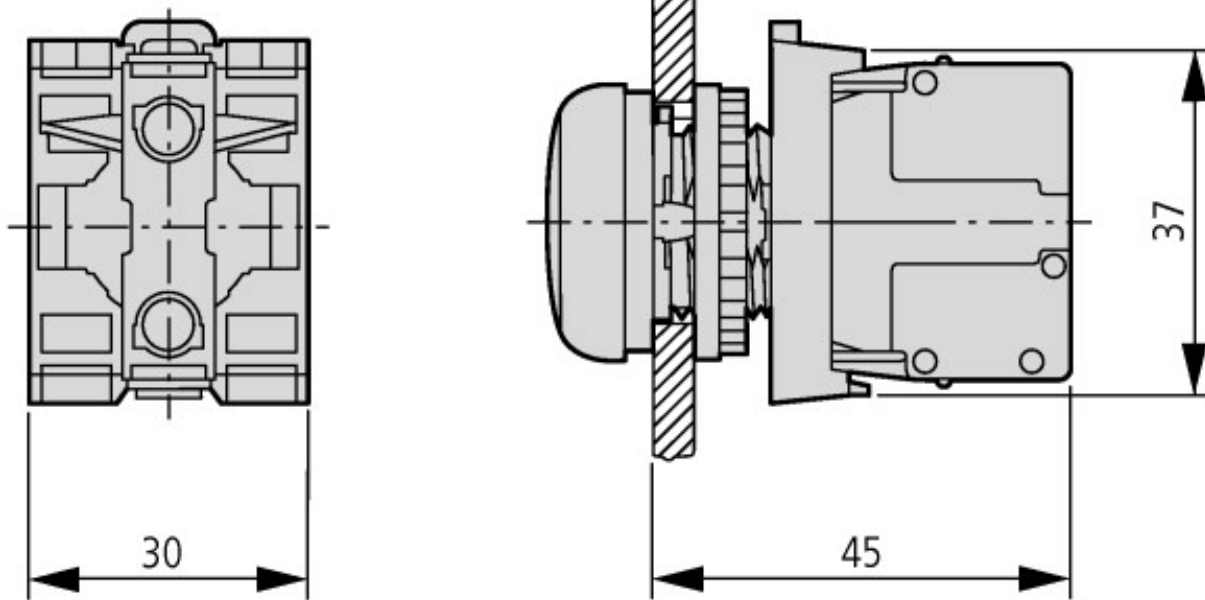

Pushbuttons and indicator lights with M22-TC telescopic clip and M22-TCV extension

① Top-hat rail to IEC/EN 60715

Additional product information (links)

IL04716002Z (AWA1160-1745) RMQ-Titan System	ftp://ftp.moeller.net/DOCUMENTATION/AWA_INSTRUCTIONS/IL04716002Z2011_03.pdf
Engineering	
Key to part numbers	ftp://ftp.moeller.net/DOCUMENTATION/PDF/GB/TYPENSCHLUESSEL_RM-Q-TITAN_de.pdf
Engineering	ftp://ftp.moeller.net/DOCUMENTATION/PDF/GB/PRO_RM-Q-Titan_D_de.pdf
Ordering example for custom complete units	ftp://ftp.moeller.net/DOCUMENTATION/PDF/GB/Bestellbeispiel_F0315_COMBINATION_de.pdf
Order form for custom complete units	ftp://ftp.moeller.net/DOCUMENTATION/PDF/GB/FORM_F0315_Combination_de.pdf