

VACUUM FLUORESCENT DISPLAY MODULE**ENGINEERING PROPOSAL**M12BY02AA**EVALUATION**

- ACCEPTED WITHOUT ANY CHANGE  
 THE FOLLOWING CHANGE IS REQUIRED

MAR 10,2008

Engineering Group

Electronic Components Division

**Futaba Corporation**

ISSUED BY

Yasuo Ohno

CHECKED BY

Hiroaki Takano

CHECKED BY

Katsunori Kore

APPROVED BY

Soichi Iijima

## Important Safety Notice

Please read this note carefully before using the product.

### Warning

- The module should be disconnected from the power supply before handling.
- The power supply should be switched off before connecting or disconnecting the power or interface cables.
- Do not touch the electronic components of the module with any metal objects.
- The VFD used on the module is made of glass and should be handled with care. When handling the VFD, it is recommended that cotton gloves be used.
- The module is equipped with a circuit protection Reset table Fuse.
- Under no circumstances should the module be modified or repaired. Any unauthorized modifications or repairs will invalidate the product warranty.
- The module should be abolished as the factory waste.

## 1. FEATURES

M12BY02AA can be displayed dot matrix characters.

The module can be configured for a I2C interface.

The necessary power supply is 5V DC only.

The module has 3pcs LED and IR Receiver.

## 2. GENERAL DESCRIPTION

### 2-1. DIMENSIONS, WEIGHT (Refer to FIGURE-4)

Table-1

| Item             | Specification | Unit |
|------------------|---------------|------|
| Outer dimensions | (W) 115±1     | mm   |
|                  | (H)25±1       |      |
|                  | (T)21.9max.   |      |
| Weight           | T.B.D         | g    |

### 2-2. SPECIFICATIONS OF THE DISPLAY PANEL

Table-2

| Item                 | Specification     | Unit              |
|----------------------|-------------------|-------------------|
| Display Area         | 64.7(W)×7.0(H)    | mm                |
| Number of Characters | 12 characters     | –                 |
| Luminance            | Green 1000 (Typ.) | cd/m <sup>2</sup> |

### 2-3. ENVIRONMENT CONDITIONS

Table-3

| Item                  | Symbol    | Min. | Max. | Unit |
|-----------------------|-----------|------|------|------|
| Operation Temperature | $T_{opr}$ | -20  | +70  | °C   |
| Storage Temperature   | $T_{stg}$ | -40  | +85  | °C   |
| Operating Humidity    | $H_{opr}$ | 0    | 80   | %    |
| Storage Humidity      | $H_{stg}$ | 0    | 90   | %    |
| Vibration (10 ~ 55Hz) | –         | –    | 4    | G    |
| Shock                 | –         | –    | 40   | G    |

Note) Avoid operations and or storage in moist environmental conditions

### 2-4. ABSOLUTE MAXIMUM RATINGS

Table-4

| Item                 | Symbol   | Min. | Max.         | Unit |
|----------------------|----------|------|--------------|------|
| Supply Voltage       | $V_{cc}$ | -0.3 | 6.0          | Vdc  |
| Input Signal Voltage | $V_{IS}$ | -0.3 | $V_{cc}+0.3$ | V    |

### 2-5. RECOMMEND OPERATING CONDITIONS

Table-5

| Item                  | Symbol   | Min.                | Typ. | Max.                | Unit |
|-----------------------|----------|---------------------|------|---------------------|------|
| Supply Voltage        | $V_{cc}$ | 4.5                 | 5.0  | 5.5                 | Vdc  |
| L-Level Input Voltage | $V_{IL}$ | 0                   | –    | $V_{cc} \times 0.3$ | V    |
| H-Level Input Voltage | $V_{IH}$ | $V_{cc} \times 0.7$ | –    | $V_{cc}$            | V    |

## 2-6. ELECTRICAL CHARACTERISTICS

Table-6

| Item                  | Symbol   | Condition         | Min.  | Typ.  | Max. | Unit              |
|-----------------------|----------|-------------------|-------|-------|------|-------------------|
| Supply Current (Note) | $I_{cc}$ | $V_{cc} = 5.0Vdc$ | -     | 240   | 350  | mA                |
| Power Consumption     | -        |                   | -     | 1.20  | 1.75 | W                 |
| Luminance (VFD)       | $L(G)$   | $V_{cc} = 5.0Vdc$ | 500   | 1000  | -    | cd/m <sup>2</sup> |
| Luminance (LED)       | $L(G)$   | $I_F = T.B.D$     | T.B.D | T.B.D | -    | cd/m <sup>2</sup> |
| Luminance (LED)       | $L(R)$   | $I_F = T.B.D$     | T.B.D | T.B.D | -    | cd/m <sup>2</sup> |
| Luminance (LED)       | $L(Y)$   | $I_F = T.B.D$     | T.B.D | T.B.D | -    | cd/m <sup>2</sup> |

Note) The surge current can be approx. 5times the specified supply current at power on.

## 2-7. AC CHARACTERISTICS

Table-7

| Symbol       | Parameter                  | Remark   | Min  | Max | Unit |
|--------------|----------------------------|--|------|-----|------|
| $f_{sk}$     | Clock Frequency            | -  | -    | 400 | KHz  |
| $t_{HIGH}$   | Clock High Time            | -  | 600  | -   | ns   |
| $t_{LOW}$    | Clock Low Time             | -  | 1200 | -   | ns   |
| $t_R$        | SDA and SCL Rise Time      | -  | -    | 300 | ns   |
| $t_F$        | SDA and SCL Fall Time      | -  | -    | 300 | ns   |
| $t_{HD:STA}$ | START Condition Hold Time  | After this period the first clock pulse is generated                   | 600  | -   | ns   |
| $t_{SU:STA}$ | START Condition Setup Time | Only relevant for repeated START condition                             | 600  | -   | ns   |
| $t_{HD:DAT}$ | Data Input Hold Time       | -  | 0    | -   | ns   |
| $t_{SU:DAT}$ | Data Input Setup Time      | -  | 100  | -   | ns   |
| $t_{SU:STO}$ | STOP Condition Setup Time  | -  | 600  | -   | ns   |
| $t_{BUF}$    | Bus Free Time              | Time in which the bus must be free before a new transmission can start | 1200 | -   | ns   |
| $t_{SP}$     | Input Filter Time Constant | Noise suppression time   | -    | 50  | ns   |
| $t_{WR}$     | Write Cycle Time           | -  | 1    | -   | us   |

**Timing Diagrams**

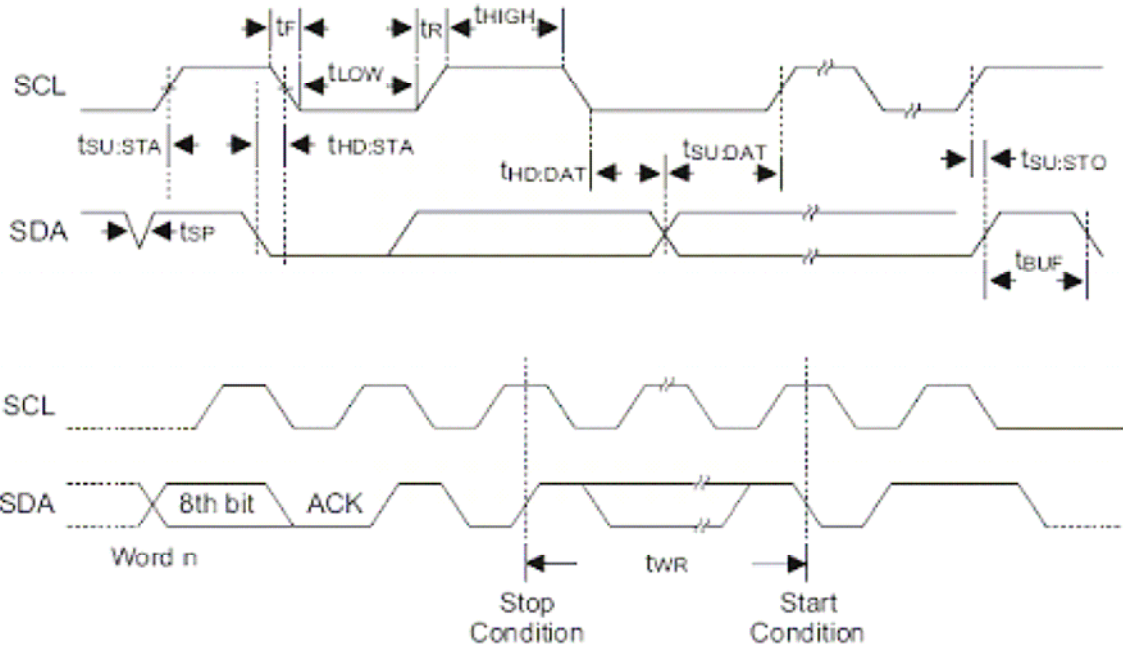

Note) The write cycle time  $t_{WR}$  is the time from a valid stop condition of a write sequence to the end of the valid start condition of sequential command.

**Display timing**

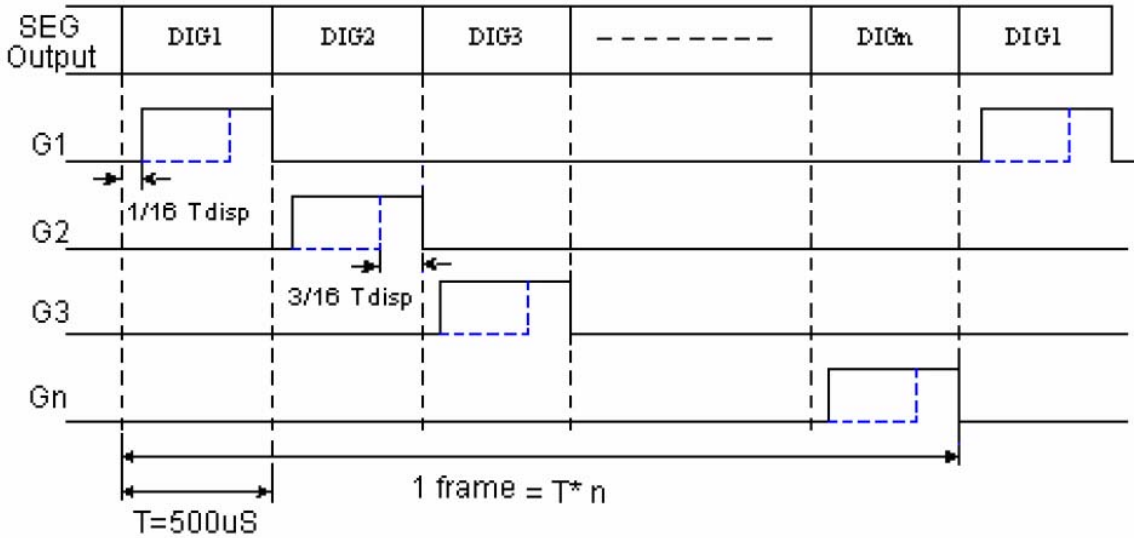

Note) The data of  $16 * 2$  matrixes is stored in RAM

**3.FUNCTION DESCRIPTION**

**3-1. Display RAM and display mode**

The static display RAM stores the data which is transmitted form external device to the controller IC through a serial interface. The contents of the RAM are directly mapped to the outputs of the VFD driver. Data in the RAM can be accessed through the data setting , address setting and display control commands. It is assigned addresses in 8-bit unit as follows.

| Seg1              | Seg4              | Seg8              | Seg12             | Seg16             | Seg20             | Seg24 |       |
|-------------------|-------------------|-------------------|-------------------|-------------------|-------------------|-------|-------|
| 00 H <sub>L</sub> | 00 H <sub>U</sub> | 01 H <sub>L</sub> | 01 H <sub>U</sub> | 02 H <sub>L</sub> | 02 H <sub>U</sub> |       | DIG1  |
| 03 H <sub>L</sub> | 03 H <sub>U</sub> | 04 H <sub>L</sub> | 04 H <sub>U</sub> | 05 H <sub>L</sub> | 05 H <sub>U</sub> |       | DIG2  |
| 06 H <sub>L</sub> | 06 H <sub>U</sub> | 07 H <sub>L</sub> | 07 H <sub>U</sub> | 08 H <sub>L</sub> | 08 H <sub>U</sub> |       | DIG3  |
| 09 H <sub>L</sub> | 09 H <sub>U</sub> | 0A H <sub>L</sub> | 0A H <sub>U</sub> | 0B H <sub>L</sub> | 0B H <sub>U</sub> |       | DIG4  |
| 0C H <sub>L</sub> | 0C H <sub>U</sub> | 0D H <sub>L</sub> | 0D H <sub>U</sub> | 0E H <sub>L</sub> | 0E H <sub>U</sub> |       | DIG5  |
| 0F H <sub>L</sub> | 0F H <sub>U</sub> | 10 H <sub>L</sub> | 10 H <sub>U</sub> | 11 H <sub>L</sub> | 11 H <sub>U</sub> |       | DIG6  |
| 12 H <sub>L</sub> | 12 H <sub>U</sub> | 13 H <sub>L</sub> | 13 H <sub>U</sub> | 14 H <sub>L</sub> | 14 H <sub>U</sub> |       | DIG7  |
| 15 H <sub>L</sub> | 15 H <sub>U</sub> | 16 H <sub>L</sub> | 16 H <sub>U</sub> | 17 H <sub>L</sub> | 17 H <sub>U</sub> |       | DIG8  |
| 18 H <sub>L</sub> | 18 H <sub>U</sub> | 19 H <sub>L</sub> | 19 H <sub>U</sub> | 1A H <sub>L</sub> | 1A H <sub>U</sub> |       | DIG9  |
| 1B H <sub>L</sub> | 1B H <sub>U</sub> | 1C H <sub>L</sub> | 1C H <sub>U</sub> | 1D H <sub>L</sub> | 1D H <sub>U</sub> |       | DIG10 |
| 1E H <sub>L</sub> | 1E H <sub>U</sub> | 1F H <sub>L</sub> | 1F H <sub>U</sub> | 20 H <sub>L</sub> | 20 H <sub>U</sub> |       | DIG11 |
| 21 H <sub>L</sub> | 21 H <sub>U</sub> | 22 H <sub>L</sub> | 22 H <sub>U</sub> | 23 H <sub>L</sub> | 23 H <sub>U</sub> |       | DIG12 |

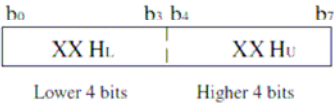

**3-2. Diming control**

Controller IC provides 15-step dimmer function on display by controlling the 4-bit binary command mode. The full pulse width of grid signal is divides into 16 uniform sections by PWM(pulse width modulation)technology.

The 16 uniform sections available form 15 steps dimmer via 3-bit binary code. The 1/16 pulse width indicates minimum lightness. The 15/16 pulse width represents maximum lightness (Refer to the display control command)

**3-3. LED port**

Data is written to the LED port with the write command , starting form the least port’s least significant bit.

When a bit of this port is 0,the corresponding LED lights ; when the bit is 1,the LED turns off. The data of bit 3 through 7 are ignored.

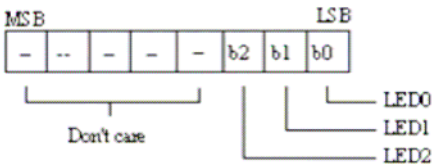

## 4.INTERFACE

The I2C interface supports write command only.

If the bit following device address is set "1",The controller IC will not assert ACK.

- **A0,A1,A2**

As many as eight devices may be addressed on a single bus system.

- **Start condition**

The START signal is generated only by the master device.

A high-to-low transition of SDA with SCL high is a start condition which must precede any other command.

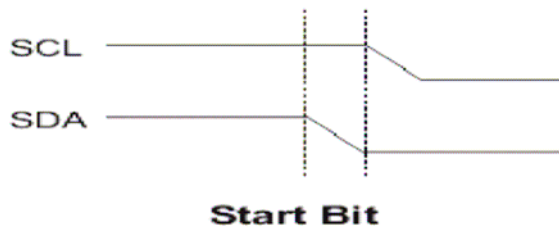

- **Stop condition**

The Stop signal is generated only by the master device. A low-to-high transition of SDA with SCL High is a stop condition.

After a read sequence , the stop command will place the controller IC in a initial state.

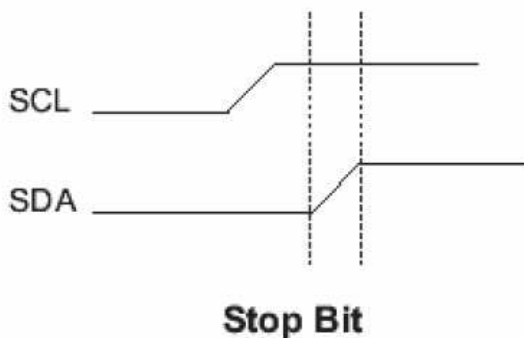

- **Acknowledge**

All addresses and data words are serially transmitted to and from the controller IC in 8-bit words.

The controller IC sends a zero to acknowledge that it has received each word.

This happens during the ninth clock cycle.

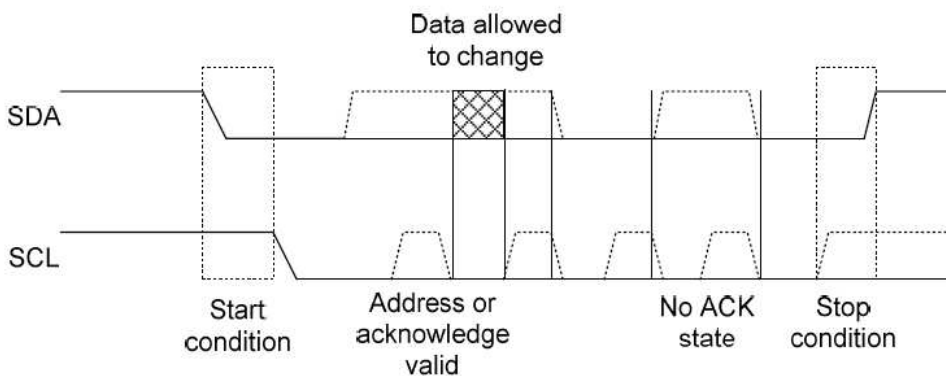

## • Device Addressing

The Controller IC requires an 8-bit device address word following a start condition to enable the chip for a write operation. The device address word consist of a mandatory one , zero sequence for the first four most significant bits(refer to the diagram showing the Device Address).This is common to all the control IC.

The next three bits are the A2 , A1 and A0 device address bits for the controller IC.

These three bits must compare to their corresponding hard-wired input pin.

If the comparison of the device address succeed , the controller IC will output a zero at ACK bit.

If not , the chip will return to a standby state.

The R/W bit must set to “0” because controller IC only supports write command.

If the bit following device address is set “1”,the controller IC will not assert ACK.

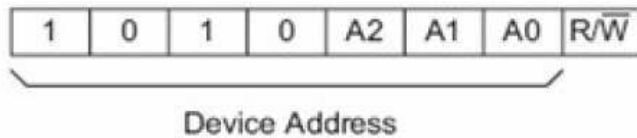

## • Write Operations

### Command write :

1. Command write include Device address word and Command word.(refer to Command writetiming)
2. A write operation requires an 8-bit data word include the device address and a “0”bit.  
Upon receipt of this address ,The controller IC will respond with a zero and receive anther 8-bit command Data word ,then controller IC will again respond with a zero. The micro controller must terminate the Command write sequence with a stop condition.

### Byte write :

1. Byte write include Device address and a “0”bit, Command word and data word (refer to Command write timing)
2. A write operation requires an 8 bit data word include the device address and a”0”bit.  
Upon receipt of this address, the controller IC will respond with a zero and receive first 8-bit command data word, then the controller IC will respond with a zero and receive second 8-bit data word.finally controller IC will again respond with a zero. The microcontroller must terminate the Byte write Sequence with a stop condition.

### Page write :

1. A page write is initiated in the same way as a byte write, but the microcontroller does not send a stop condition after the first data word is clocked in.Instead,after the controller IC acknowledges the receipt of the first data word,the microcontroller can transmit up to 35 more data words.  
The controller IC will respond with a stop condition(refer to Page write timing)
2. The address defined by address setting command is incremented internally following the receipt of each data word.



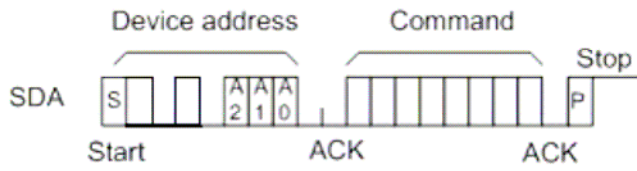

Command Write Timing

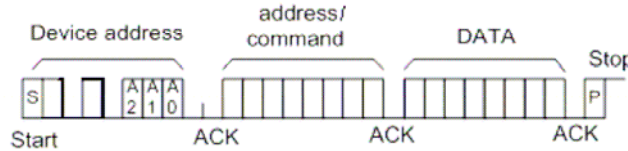

Byte Write Timing

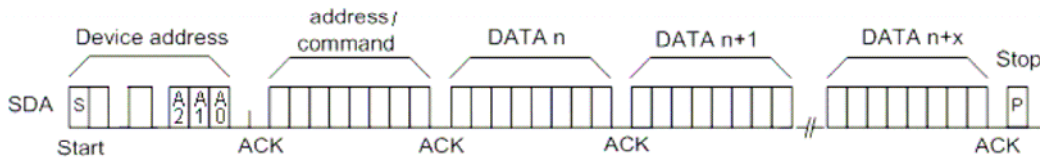

Page Write Timing

**Acknowledge polling :**

To maximize bus throughput, one technique is to allow the master to poll for an acknowledge signal. After the start condition and the control byte for a write command have been sent. If the device is still busy implementing its write cycle, then no ACK will be returned. The master can send the next command/data when ACK signal has finally been received.

If no acknowledge bit, the master must send a STOP bit and end the communication.

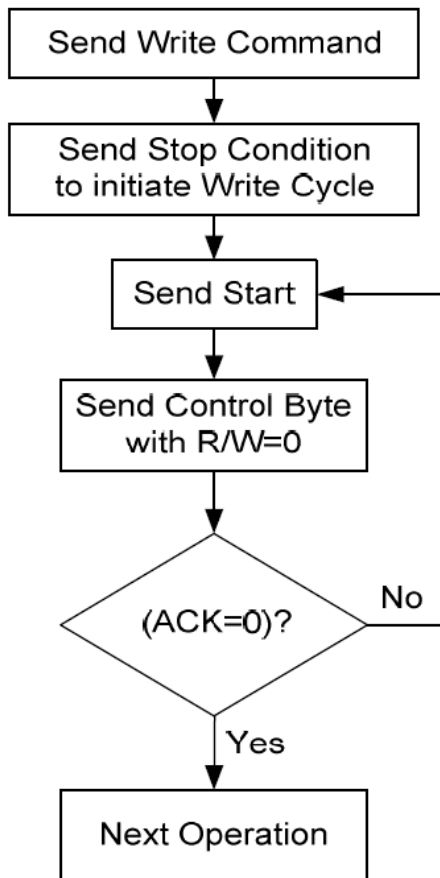

Acknowledge Polling Flow

**5.COMMANDS**

**5-1.Display mode setting commands**

This command is selects the number of segments and number of grid.(12digits,16segments)

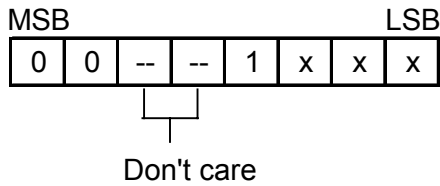

Power on status : 12-digit,16 segment mode is selected.

**5-2.Data setting commands**

These commands set the data write and data read modes.

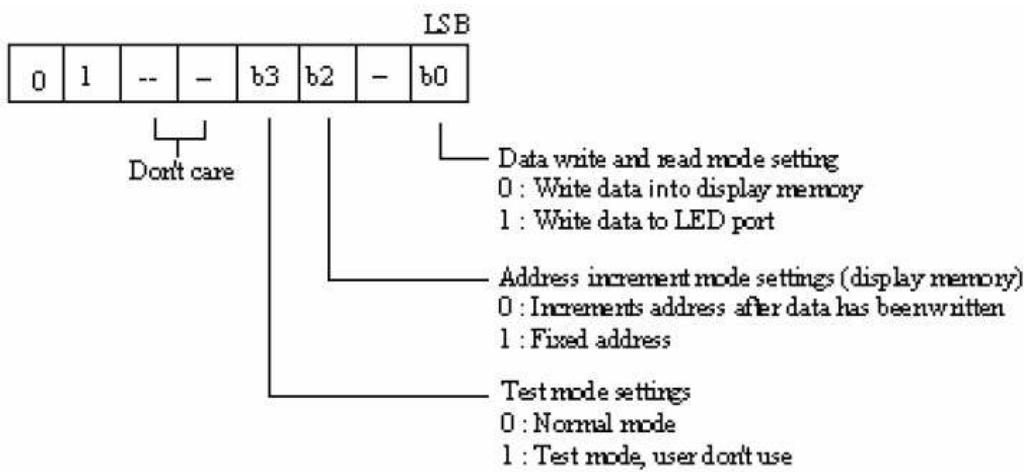

**5-3.Address setting commands**

These command set the address of the display command.

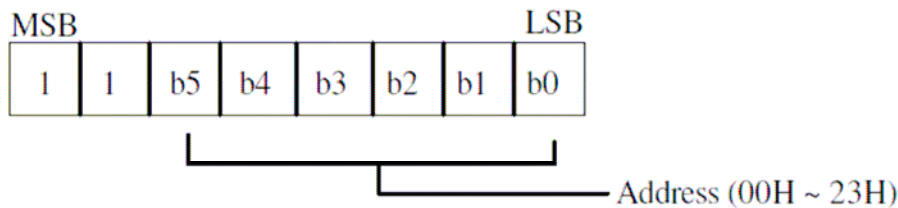

If address 24H or higher is set ,the data is ignored ,until a correct address is set.  
 Power on status : the address is set to 00H.



**7.VFD PATTERN DETAIL**

FIGURE-1

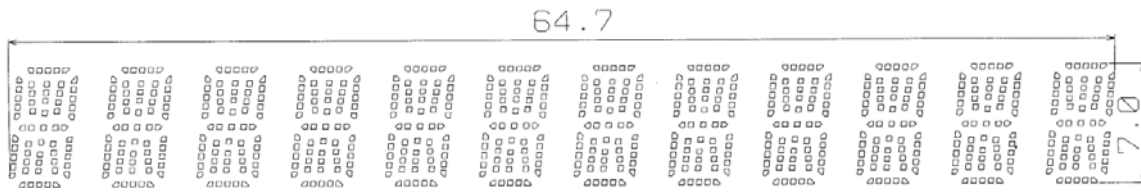

COLOR OF ILLUMINATION

Green (G. x=0.24,y=0.41) - - - - - A00 graphics.

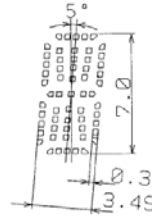
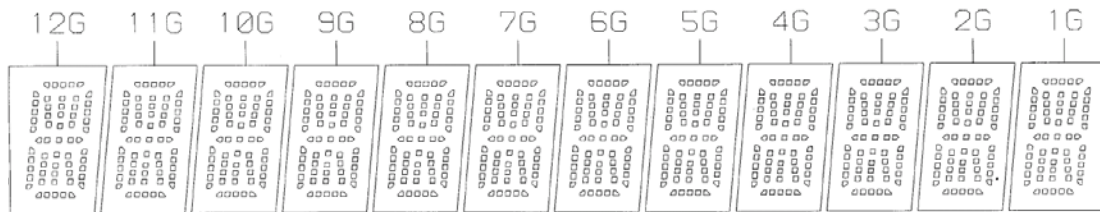

FIGURE-2



**8. The environmental specifications for this product**

1. With respect to EU RoHS Directive

The contained amount of six prohibited substances in this product , which are cadmium, hexavalent chromium, lead, mercury, polybrominated biphenyl:PBB and polybrominated diphenyl ether :PBDE, is less than the permitted level stipulated in the EU RoHS Directive, or these substances are not included in the Directive.

The substances excluded are based on Article 4 of the EU RoHS Directive.

2. With respect to Chinese RoHS

This product contains only “lead and its compound” from among six controlled substances, which are cadmium, hexavalent chromium, lead, mercury, polybrominated biphenyl:PBB and polybrominated diphenyl ether :PBDE.

The contained amount of the controlled substances except lead and its compound in this product is less than the level stipulated in the Chinese RoHS.

As for the display of information on containing EHS, please refer to the following.

< Display of information on containing EHS >

\*Product and part the substances are contained : Vacuum Fluorescent Display(VFD)

\*Chemical materials contained : Lead and its compound

\*Time limit of use for environmental protection : 10 years

\*Reason for containing the substances: No materials are available except them under the current technology.

**CIRCUIT BLOCK DIAGRAM**

FIGURE-3

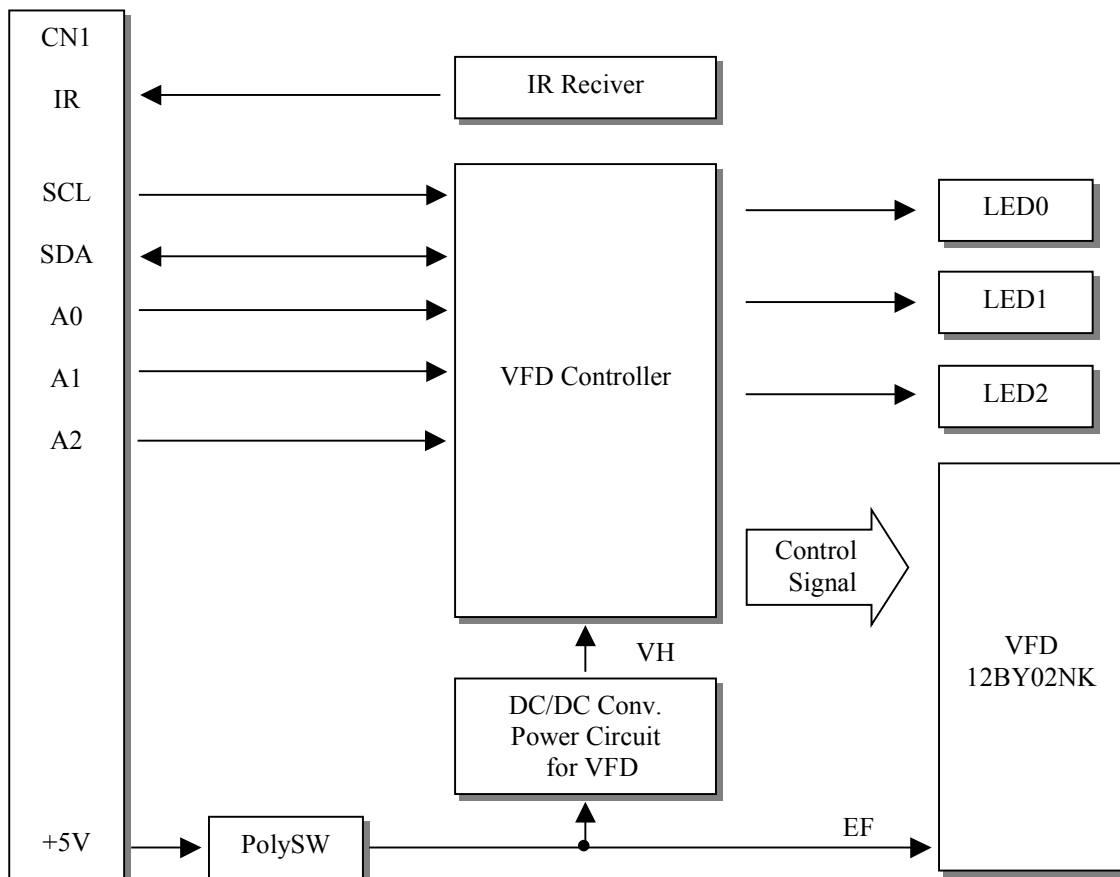

**OUTER DIMENSION**

FIGURE-4

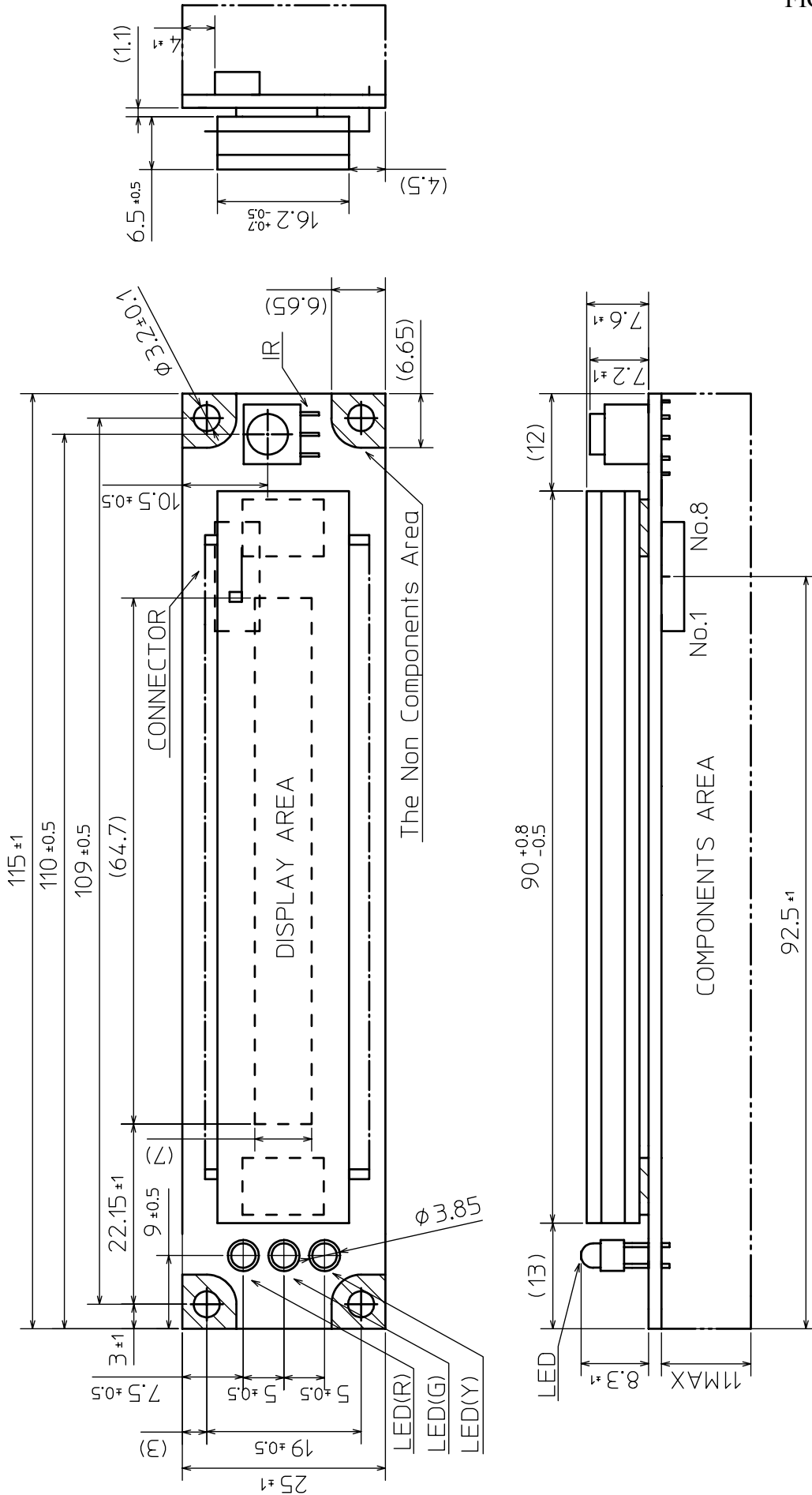
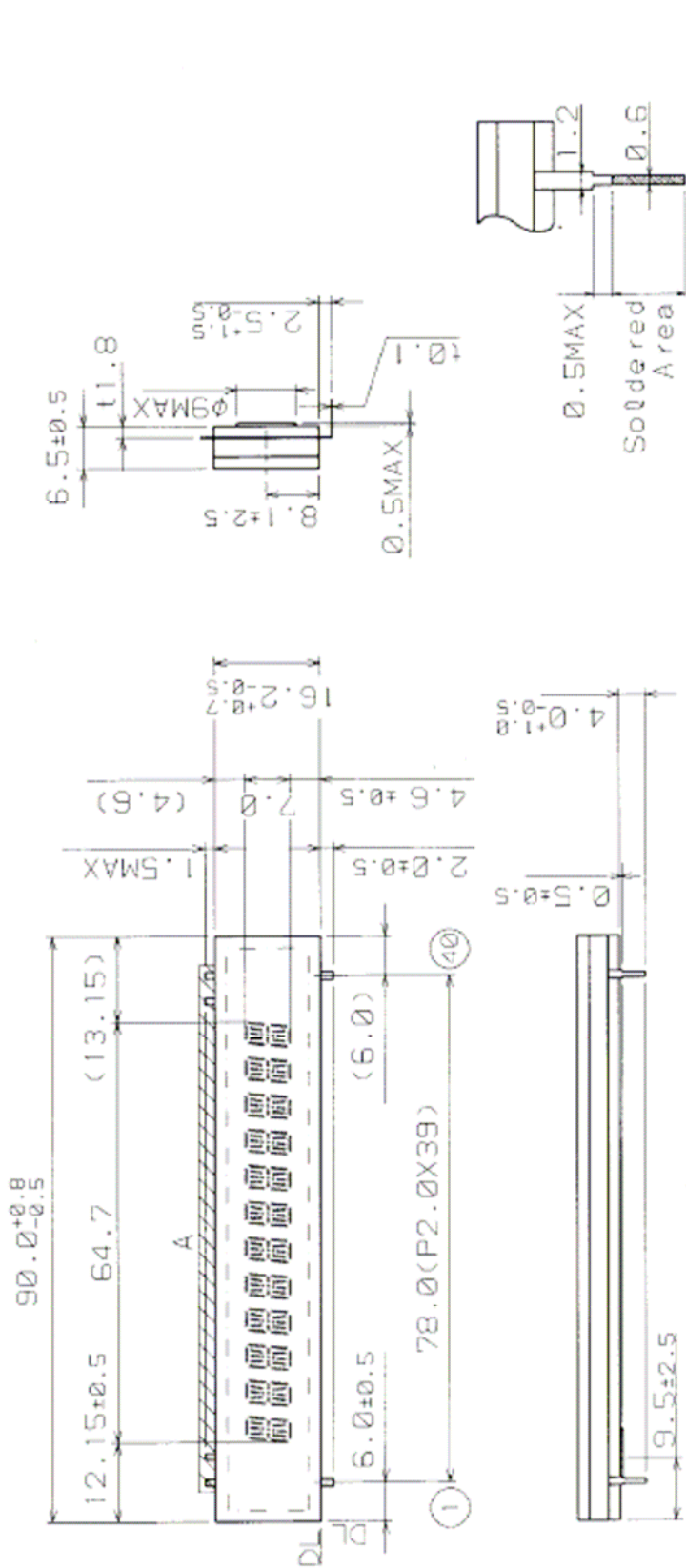

FIGURE-5



LEAD DETAILS  
**LEAD FREE SOLDER**

|            |   |   |   |   |   |   |   |   |   |    |    |    |    |    |    |    |    |    |    |    |    |    |    |    |    |    |    |    |    |    |    |    |    |    |
|------------|---|---|---|---|---|---|---|---|---|----|----|----|----|----|----|----|----|----|----|----|----|----|----|----|----|----|----|----|----|----|----|----|----|----|
| PIN NO.    | 1 | 2 | 3 | 4 | 5 | 6 | 7 | 8 | 9 | 10 | 11 | 12 | 13 | 14 | 15 | 16 | 17 | 18 | 19 | 20 | 21 | 22 | 23 | 24 | 25 | 26 | 27 | 28 | 29 | 30 | 31 | 32 | 33 | 34 |
| CONNECTION | F | F | N | G | G | G | P | G | G | r  | G  | n  | e  | G  | c  | g  | G  | m  | G  | f  | b  | G  | h  | G  | k  | G  | j  | G  | G  | a  | P  | +  |    |    |

- NOTE
- 1) F-,F+ --- Filament
  - 2) NP ----- No pin
  - 3) DL ----- Datum Line
  - 4) 1G~12G --- Grid
  - 5) 1.5MAX is applied to all the leads inside A area
  - 6) Solder composition is Sn-3Ag-0.5Cu

(unit in mm)  
12-BY-02NK  
OUTER DIMENSION

**DISPLAY RAM – VFD Connection**

FIGURE-6

| Display RAM | Connection | Display RAM | Connection |
|-------------|------------|-------------|------------|
| SEG1        | a          | DIG1        | 1G         |
| SEG2        | b          | DIG2        | 2G         |
| SEG3        | c          | DIG3        | 3G         |
| SEG4        | d          | DIG4        | 4G         |
| SEG5        | e          | DIG5        | 5G         |
| SEG6        | f          | DIG6        | 6G         |
| SEG7        | g          | DIG7        | 7G         |
| SEG8        | h          | DIG8        | 8G         |
| SEG9        | j          | DIG9        | 9G         |
| SEG10       | k          | DIG10       | 10G        |
| SEG11       | m          | DIG11       | 11G        |
| SEG12       | n          | DIG12       | 12G        |
| SEG13       | p          | -           | -          |
| SEG14       | r          | -           | -          |
| SEG15       | S1         | -           | -          |
| SEG16       | S2         | -           | -          |



**9. CAUTIONS FOR OPERATION**

- 9-1. Applying lower voltage than the specified may cause non activation for selected pixels.  
Conversely, higher voltage may cause non-selected pixel to be activated.  
If such a phenomenon is observed, check the voltage level of the power supply.
- 9-2. The DC/DC converter generates approximately 31Vdc, avoid touching it with bare hands, or to other circuits.
- 9-3. Avoid using the module where excessive noise interface is expected.  
Noise affects the interface signal and causes improper operation.  
Keep the length of the interface cable less than 30cm.  
(When the longer cable is required, please confirm there is no noise affection.)
- 9-4. When power is turned off, the capacitor will not discharge immediately.  
Avoid touching IC and others.  
The shorting of the mounted components within 30 sec., after power off, may cause damage.
- 9-5. When fixed pattern is displayed for a long time, you may see uneven luminance.  
It is recommended to change the display patterns sometimes in order to keep best display quality.
- 9-6. DC/DC converter is equipped on the module, the surge current may be approximately 5 times the specified supply current at the power on.