

Electric Slide Table

New



Step Motor (Servo/24 VDC)

Servo Motor (24 VDC)

Symmetrical type (L type) and In-line motor type (D type) newly added to electric slide table basic type (R type). Improved mounting flexibility!



Symmetrical Type (L Type)



In-line Motor Type (D Type)

- Compact, Space-saving
61% reduction in volume* For R/L type (compared to the SMC conventional products)



* LESH8 R/L 50 mm stroke

- Maximum pushing force: **180 N**
- Reduced cycle time
Max. acceleration/deceleration: **5000 mm/s²**
Max. speed: **400 mm/s**
- Positioning repeatability: **±0.05 mm**

Basic Type (R Type)

Series LESH□R



Symmetrical Type (L Type)

Series LESH□L



In-line Motor Type (D Type)

Series LESH□D



Offering 2 types of controller

▶ Step Data Input Type Series LECP6/LECA6

- 64 positioning points
- Teaching box, controller setting kit input



New

▶ Programless Type Series LECP1

- 14 positioning points
- Control panel setting input



Series **LES**



CAT.EUS100-78D-UK

Electric Slide Table

Integration of the guide rail and the table.

Uses a recirculating linear guide for high rigidity and high precision.
Electric slide table for precision assembly processes.

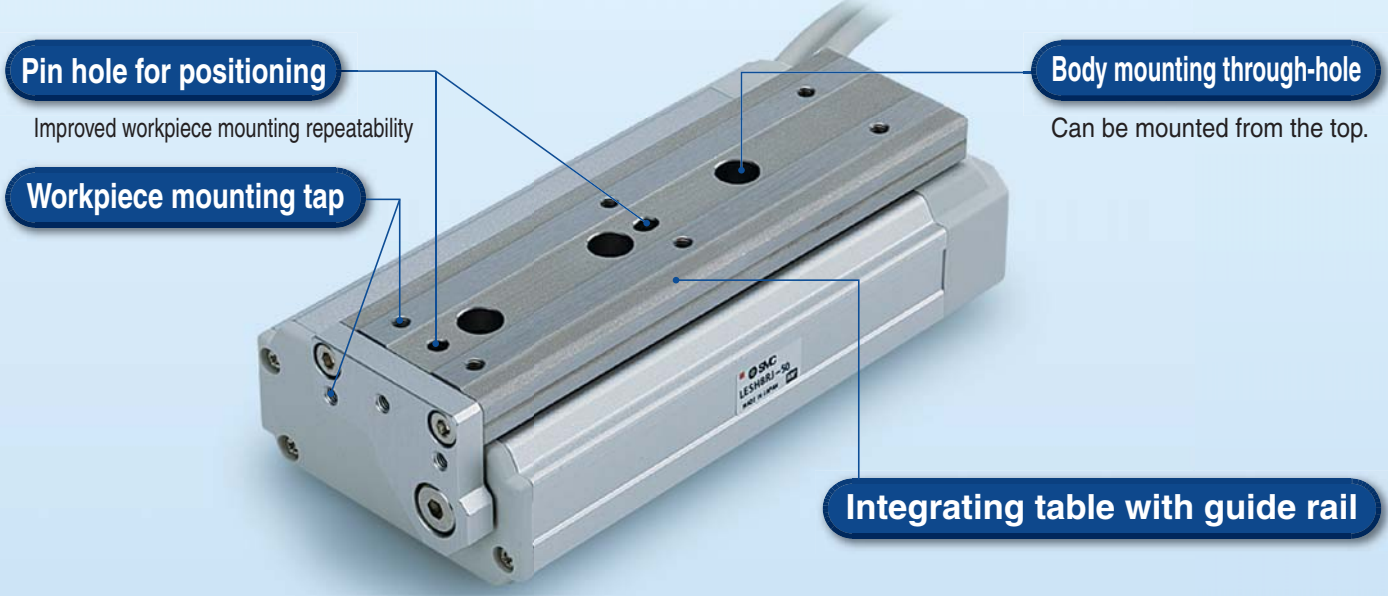

2 types of motors can be selected

- **Step motor (Servo/24 VDC)**
Ideal for transfer of high load at a low speed and pushing operation
- **Servo motor (24 VDC)**
Stable at a high speed and silent operation

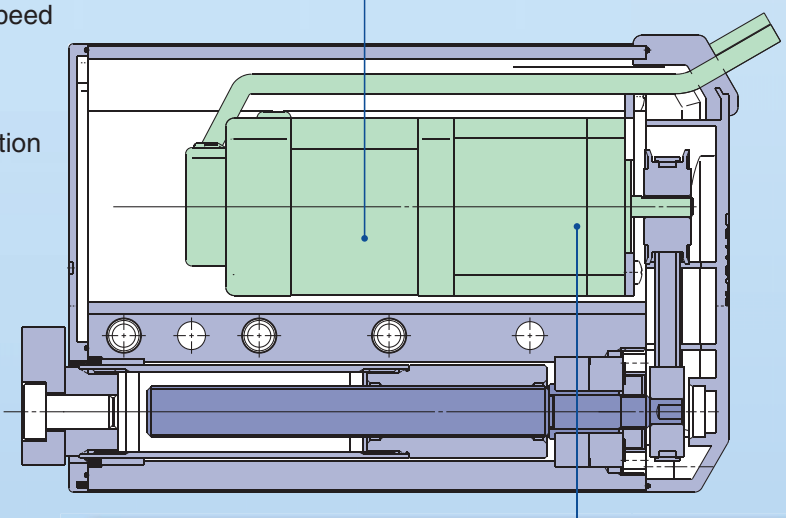
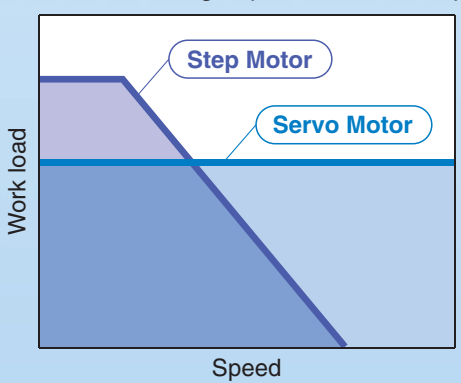

Non-magnetizing operation type lock mechanism (Option)

Prevents work pieces from dropping (holding)

Application Examples

Positioning of pallets on a conveyor

Z motion for pick and place

New Symmetrical Type (L Type)

The locations of the table and cable are opposite those of the basic type (R type), expanding design applications.

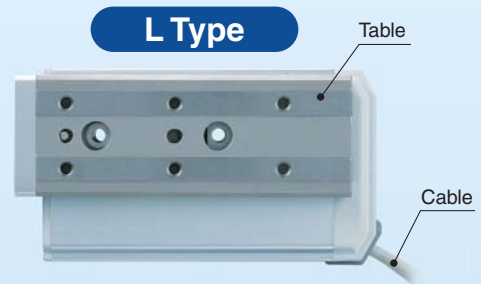
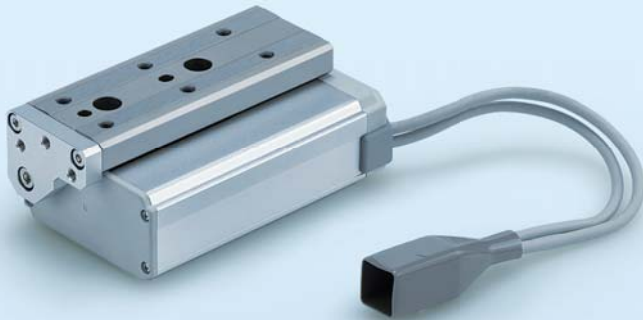

Installation example

When two tables are installed side by side, they will not interfere with each other, allowing for space saving.

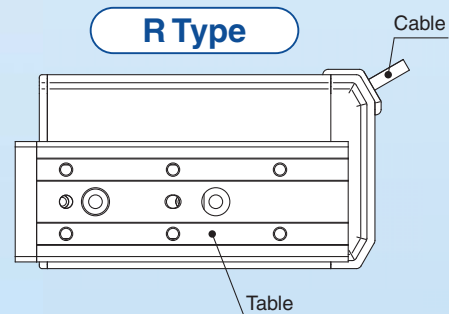
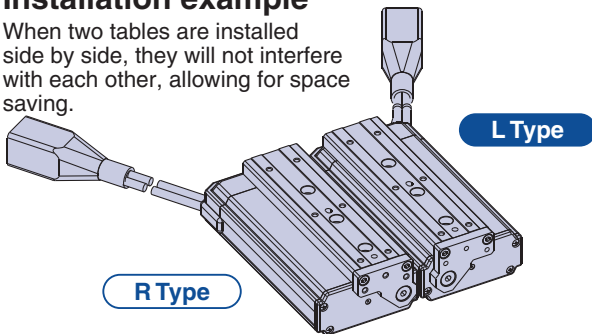

New In-line Motor Type (D Type)

Width dimension shortened by up to **45%**



D Type

R Type

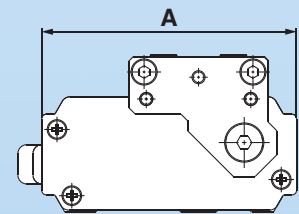
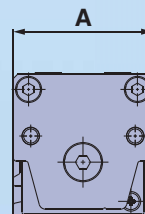

A Dimension		[mm]
Size	D type	R/L type
8	32	58.5
16	45	72.5
25	61	106

How to mount

Through-hole mounting (R/L/D Type)

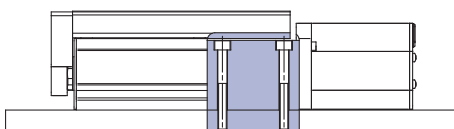

Side holder mounting (D Type)

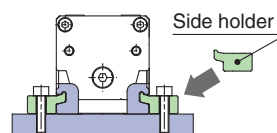

Body tapped mounting (R/L/D Type)

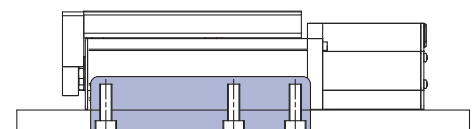

Offering 2 Types of Controller

Step Data Input Type Series LECP6/LECA6

Simple Setting to Use Straight Away

Simple Setting Easy Mode

If you want to use it right away, select "Easy Mode."



Step Motor
(Servo/24 VDC)
LECP6



Servo Motor
(24 VDC)
LECA6

<When using a PC>

Controller setting software

- Step data setting, test operation, move jog and move for the constant rate can be set and operated on one screen.

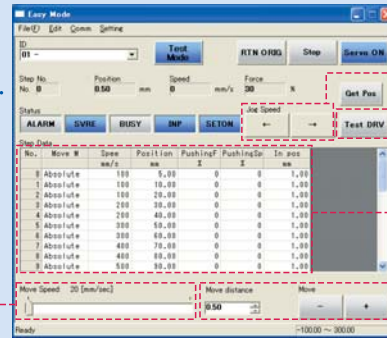

Setting of jog and speed of the constant rate

Move jog

Start testing

Step data setting

Move for the constant rate

<When using a TB (teaching box)>

- The simple screen without scrolling promotes ease of setting and operating.
- Pick up an icon from the first screen and select a function.
- Set up the step data and check the monitor on the second screen.



Example of setting the step data

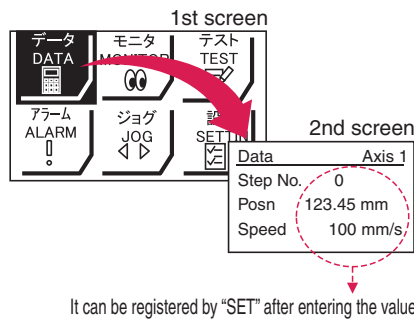

Example of checking the monitor

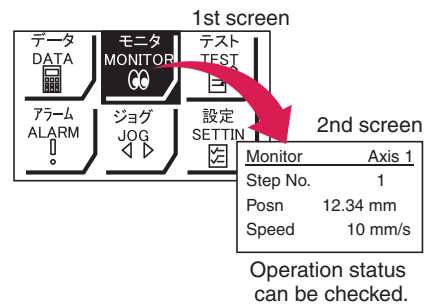

Teaching box screen

- Data can be set with position and speed. (Other conditions are already set.)

Data	Axis 1
Step No.	0
Posn	50.00 mm
Speed	200 mm/s

Data	Axis 1
Step No.	1
Posn	80.00 mm
Speed	100 mm/s

Programless Type Series LECP1

No programming

Capable of setting up an electric actuator operation without using a PC or teaching box

Step Motor
(Servo/24 VDC)
LECP1



1 Setting position number

Setting a registered number for the stop position
Maximum 14 points

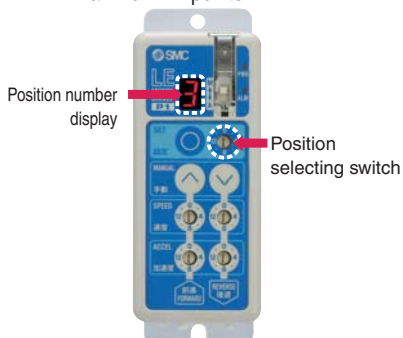

2 Setting a stop position

Moving the actuator to a stop position using FORWARD and REVERSE buttons



3 Registration

Registering the stop position using SET button



Speed/acceleration
16-level adjustment

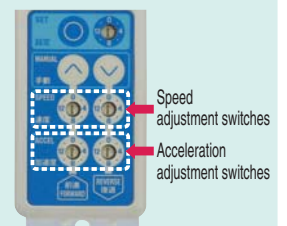

◎Detail Setting Normal Mode

Select normal mode when detail setting is required.

- Step data can be set in detail.
- Parameters can be set.
- Signals and terminal status can be monitored.
- JOG and constant rate movement, return to origin, test operation and testing of compulsory output can be performed.

<When using a PC>
Controller setting software

- Step data setting, parameter setting, monitor, teaching, etc., are indicated in different windows.

Step data setup window

Parameter setup window

Monitoring window

Teaching window

<When using a TB (teaching box)>

- Multiple step data can be stored in the teaching box, and transferred to the controller.
- Continuous test operation by up to 5 step data.

Teaching box screen

- Each function (step data setting, test, monitor, etc.) can be selected from the main menu.

Main menu screen

Step data setup screen

Test screen

Monitoring screen

The actuator and controller are provided as a set. (They can be ordered separately.)

Confirm that the combination of the controller and the actuator is correct.

<Check the following before use.>

- ① Check that actuator label for model number. Matches the controller label.
- ② Check that the Parallel I/O configuration matches (NPN or PNP).

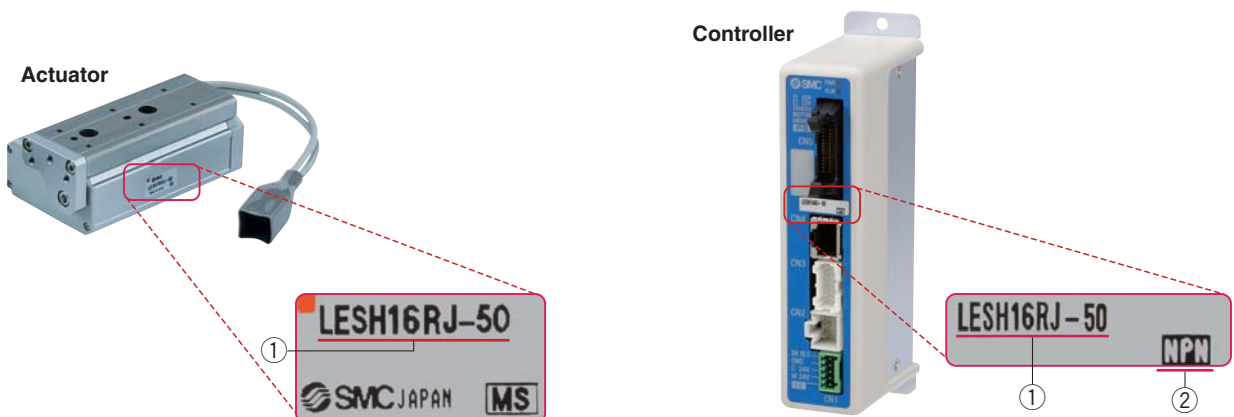

Function

Item	Step data input type LECP6/LECA6	Programless type LECP1
Step data and parameter setting	<ul style="list-style-type: none"> Input the numerical value from controller setting software (PC) Input the numerical value from teaching box 	<ul style="list-style-type: none"> Select using controller operation buttons
Step data "position" setting	<ul style="list-style-type: none"> Input the numerical value from controller setting software (PC) Input the numerical value from teaching box Direct teaching JOG teaching 	<ul style="list-style-type: none"> Direct teaching JOG teaching
Number of step data	64 points	14 points
Operation command (I/O signal)	Step No. [IN*] input ⇒ [DRIVE] input	Step No. [IN*] input only
Completion signal	[INP] output	[OUT*] output

Setting Items

TB: Teaching box PC: Controller setting software

Item	Contents	Step data input type LECP6/LECA6	Easy mode		Normal mode	Programless type LECP1	
			TB	PC	TB, PC		
Step data setting (Excerpt)	Movement MOD	Selection of "absolute position" and "relative position"	Set at ABS/INC.	×	●	●	Fixed value (ABS)
	Speed	Transfer speed	Set in units of 1 mm/s.	●	●	●	Select from 16-level
	Position	[Position]: Target position [Pushing]: Pushing start position	Set in units of 0.01 mm.	●	●	●	Direct teaching JOG teaching
	Acceleration/Deceleration	Acceleration/deceleration during movement	Set in units of 1 mm/s ² .	●	●	●	Select from 16-level
	Pushing force	Rate of force during pushing operation	Set in units of 1%.	●	●	●	Select from 3-level (weak, medium, strong)
	Trigger LV	Target force during pushing operation	Set in units of 1%.	×	●	●	No setting required (same value as pushing force)
	Pushing speed	Speed during pushing operation	Set in units of 1 mm/s.	×	●	●	Fixed value
	Positioning force	Force during positioning operation	Fixed value	×	●	●	Fixed value
	Area output	Conditions for area output signal to turn ON	Set in units of 0.01 mm.	×	●	●	—
In position	[Position]: Width to the target position [Pushing]: How much it moves during pushing	Set to 0.5 mm or more. (Units: 0.01 mm)	×	●	●	Fixed value	
Parameter setting (Excerpt)	Stroke (+)	+ side limit of position	Set in units of 0.01 mm.	×	×	●	Fixed value
	Stroke (-)	- side limit of position	Set in units of 0.01 mm.	×	×	●	Fixed value
	ORIG direction	Direction of the return to the original position can be set.	Compatible	×	×	●	Compatible
	ORIG speed	Speed when returning to the original position	Set in units of 1 mm/s.	×	×	●	Fixed value
	ORIG ACC	Acceleration when returning to the original position	Set in units of 1 mm/s ² .	×	×	●	Fixed value
Test	JOG	Continuous operation at the set speed can be tested while the switch is being pressed.	Continuous operation at the set speed can be tested while the switch is being pressed.	●	●	●	Hold down MANUAL button (⊙) for uniform sending (speed is specified value)
	MOVE	Operation at the set distance and speed from the current position can be tested.	Operation at the set distance and speed from the current position can be tested.	×	●	●	Press MANUAL button (⊙) once for sizing operation (speed, sizing amount are specified values)
	Return to ORIG		Compatible	●	●	●	Compatible
	Test drive	Operation of the specified step data	Compatible	●	●	● (Continuous operation)	Compatible
	Compulsory output	ON/OFF of the output terminal can be tested.	Compatible	×	×	●	—
Monitor	DRV mon	Current position, speed, force and the specified step data can be monitored.	Compatible	●	●	●	—
	In/Out mon	Current ON/OFF status of the input and output terminal can be monitored.	Compatible	×	×	●	—
ALM	Active ALM	Alarm currently being generated can be confirmed.	Compatible	●	●	●	Compatible (display alarm group)
	ALM Log record	Alarm generated in the past can be confirmed.	Compatible	×	×	●	—
File	Save/Load	Step data and parameter can be saved, forwarded and deleted.	Compatible	×	×	●	—
Other	Language	Can be changed to Japanese or English.	Compatible	●	●	●	—

System Construction

Supplied by customer

PLC

Power supply for I/O signal 24 VDC



● I/O cable **Pages 37, 47**

Controller type	Part No.
LECP6/LECA6	LEC-CN5-□
LECP1 (Programless)	LEC-CK4-□

● Controller



Step data input type
LECP6/LECA6
Page 29



Programless type
LECP1
Page 41

Supplied by customer

Controller power supply 24 VDC



● Power supply connection **Pages 32, 44**

Controller type	Connection
LECP6/LECA6 (Step data input type)	Power supply plug (accessory)
LECP1 (Programless type)	Power supply cable (1.5m) (accessory)

● Actuator cable **Pages 35, 36, 46**

Controller type	Standard cable	Robotic cable
LECP6 (Step data input type)	LE-CP-□-S	LE-CP-□
LECA6 (Step data input type)	—	LE-CA-□
LECP1 (Programless type)	LE-CP-□-S	LE-CP-□

Motor cable (Fixed)

● Controller setting kit (Option) **Page 38**

Controller setting kit
(Communication cable, conversion unit and USB cable are included.)
Part No.: LEC-W2

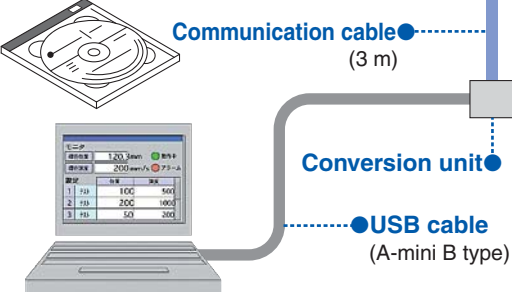

Communication cable (3 m)

Conversion unit

USB cable (A-mini B type)

PC

● Teaching box (Option) **Page 39**

Part No.: **LEC-T1-3JG** □



with 3 m cable

Or

● Electric actuator

Electric Slide Table

Page 9



SMC Electric Actuators

Rod Type

Step Motor (Servo/24 VDC)

Servo Motor (24 VDC)

AC Servo Motor (100/200 W)



CAT.ES100-83

Basic Type Series LEY

Size	Stroke
16	30 to 300
25	30 to 400
32	30 to 500



In-line Motor Type Series LEY□D

Size	Stroke
16	30 to 300
25	30 to 400
32	30 to 500



Guide Rod Type Series LEYG

Size	Stroke
16	30 to 200
25	30 to 300
32	30 to 300



In-line Motor Type /Guide Rod Type Series LEYG□D

Size	Stroke
16	30 to 200
25	30 to 300
32	30 to 300



Basic Type Series LEY

Size	Stroke
25	30 to 400
32	30 to 500



In-line Motor Type Series LEY□D

Size	Stroke
25	30 to 400
32	30 to 500



Slider Type

Step Motor (Servo/24 VDC)

Servo Motor (24 VDC)

AC Servo Motor (100/200/400 W)



CAT.ES100-87

Ball Screw Drive Series LEFS

Size	Stroke
16	100 to 400
25	100 to 600
32	100 to 800
40	200 to 1000



Belt Drive Series LEFB

Size	Stroke
16	300 to 1000
25	300 to 2000
32	300 to 2000



Ball Screw Drive Series LEFS

Size	Stroke
25	100 to 600
32	100 to 800
40	200 to 1000



Rotary Table

Step Motor (Servo/24 VDC)

Slide Table

Step Motor (Servo/24 VDC)

Servo Motor (24 VDC)



CAT.ES100-94

Basic Type Series LER

Size	Rotation angle[°]
10	310, 180, 90
30	320, 180, 90
50	



High Precision Type Series LERH

Size	Rotation angle[°]
10	310, 180, 90
30	320, 180, 90
50	



CAT.ES100-78

Basic Type (R Type) Series LESH□R

Size	Stroke
8	50, 75
16	50, 100
25	50, 100, 150



Symmetrical Type (L Type) Series LESH□L

Size	Stroke
8	50, 75
16	50, 100
25	50, 100, 150



In-line Motor Type (D Type) Series LESH□D

Size	Stroke
8	50, 75
16	50, 100
25	50, 100, 150



Gripper

Step Motor (Servo/24 VDC)



CAT.ES100-77

Z Type (2 Fingers) Series LEHZ

Size	Opening/closing stroke
10	4
16	6
20	10
25	14
32	22
40	30

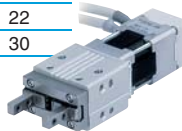

With Dust Cover Series LEHZJ

Size	Opening/closing stroke
10	4
16	6
20	10
25	14



F Type (2 Fingers) Series LEHF

Size	Opening/closing stroke
10	16 (32)
20	24 (48)
32	32 (64)
40	40 (80)



S Type (3 Fingers) Series LEHS

Size	Opening/closing stroke
10	4
20	6
32	8
40	12

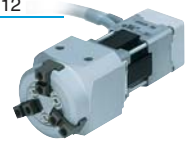

Controller

Step Data Input Type For Step Motor Series LECP6



Control motor
Step Motor
(Servo/24 VDC)

Step Data Input Type For Servo Motor Series LECA6



Control motor
Servo Motor
(24 VDC)

Programless Type Series LECP1



Control motor
Step Motor
(Servo/24 VDC)

AC Servo Motor Controller Incremental Type Series LECSA



Control motor
AC servo Motor
(100/200 VAC)

AC Servo Motor Controller Absolute type Series LECSB



Control motor
AC servo Motor
(100/200 VAC)

Series Variations

Electric Slide Table *Series LES*

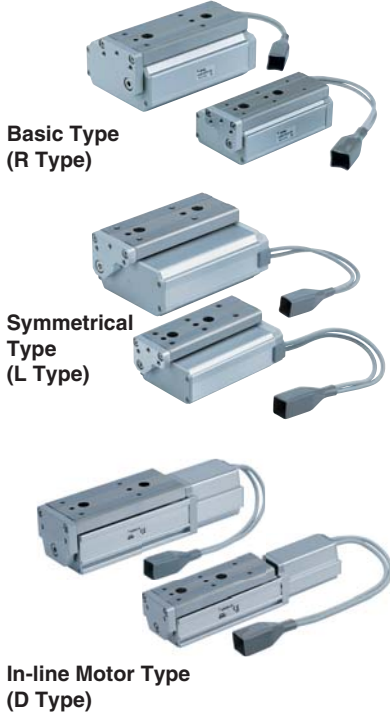

Specifications	Series	Stroke [mm]	Work load [kg]		Speed [mm/s]	Screw lead [mm]	Controller series	Page
			Horizontal	Vertical				
Step motor (Servo/24 VDC)	LESH8□	50, 75	2	0.5	10 to 200	4	Series LECP6	Page 1
			1	0.25	20 to 400	8		
	LESH16□	50, 100	6	2	10 to 200	5	Series LECP1	
			4	1	20 to 400	10		
	LESH25□	50, 100 150	9	4	10 to 150	8	Series LECA6	
			6	2	20 to 400	16		
Servo motor (24 VDC)	LESH8□A	50, 75	2	0.5	10 to 200	4	Series LECA6	
			1	0.25	20 to 400	8		
	LESH16□A	50, 100	5	2	10 to 200	5	Series LECA6	
			2.5	1	20 to 400	10		
	LESH25 ^R □A	50, 100 150	6	2.5	10 to 150	8	Series LECA6	
			4	1.5	20 to 400	16		

Model Selection

Servo Motor (24 VDC)/Step Motor (Servo/24 VDC)

LES

Controller *LEC*



Type	Series	Compatible motor	Power supply voltage	Parallel input/output		Number of positioning pattern points	Page
				Input	Output		
Step data input type	LECP6	Step motor (Servo/24 VDC)	24 VDC ±10%	11 inputs (Photo-coupler isolation)	13 outputs (Photo-coupler isolation)	64	Page 29
	LECA6	Servo motor (24 VDC)					
Programless type	LECP1	Step motor (Servo/24 VDC)	24 VDC ±10%	6 inputs (Photo-coupler isolation)	6 outputs (Photo-coupler isolation)	14	Page 41

LECA6 / LECP6

LECP1

Specific Product Precautions

INDEX

Step Motor (Servo/24 VDC)/Servo Motor (24 VDC) Type



◎ Electric Slide Table Series LES

Model Selection	Page 1
How to Order	Page 9
Specifications	Page 11
Construction	Page 13
Dimensions	Page 15
Specific Product Precautions	Page 25



◎ Step Motor (Servo/24 VDC) /Servo Motor (24 VDC) Controller

Step Data Input Type/Series LECP6/LECA6	Page 29
Controller Setting Kit/ LEC-W2	Page 38
Teaching Box/ LEC-T1	Page 39
Programless Controller/Series LECP1	Page 41

Series LES

Model Selection 1



Selection Procedure

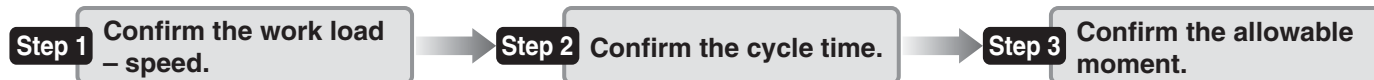

Selection Example

Step 1 Confirmation of work load-speed <Speed-Work load graph> (Page 2)

Select the target model based on the workpiece mass and speed with reference to the <Speed-Work load graph>. Selection example) The LESH16□J-50 is temporarily selected based on the graph shown on the right side.

Step 2 Confirmation of cycle time

It is possible to roughly calculate the cycle time by using method 1, however, if more detailed cycle time is required, use method 2.
* Although it is possible to calculate a guideline cycle time by using method 1, this calculation is based on the condition where the maximum load is mounted. Therefore, if it is necessary to find out a more detailed cycle time for a specific load, use method 2.

Method 1: Confirmation by graph <Cycle time> (Page 3)

Method 2: Confirmation by calculation <Speed-Work load graph> (Page 2)

Calculate the cycle time using the following calculation method. Calculation example) T1 to T4 can be calculated as follows.

Cycle time:

T can be found from the following equation.

$$T = T1 + T2 + T3 + T4 \text{ [s]}$$

- T1: Acceleration time and T3: Deceleration time can be obtained by the following equation.

$$T1 = V/a1 \text{ [s]} \quad T3 = V/a2 \text{ [s]}$$

- T2: Constant speed time can be found from the following equation.

$$T2 = \frac{L - 0.5 \cdot V \cdot (T1 + T3)}{V} \text{ [s]}$$

- T4: Settling time varies depending on the conditions such as motor types, load and in positioning of the step data. Therefore, please calculate the settling time with reference to the following value.

$$T4 = 0.15 \text{ [s]}$$

$$T1 = V/a1 = 220/5000 = 0.04 \text{ [s]}$$

$$T3 = V/a2 = 220/5000 = 0.04 \text{ [s]}$$

$$T2 = \frac{L - 0.5 \cdot V \cdot (T1 + T3)}{V} = \frac{50 - 0.5 \cdot 220 \cdot (0.04 + 0.04)}{220} = 0.19 \text{ [s]}$$

$$T4 = 0.15 \text{ [s]}$$

Therefore, the cycle time can be obtained as follows.

$$T = T1 + T2 + T3 + T4 = 0.04 + 0.19 + 0.04 + 0.15 = 0.42 \text{ [s]}$$

Operating conditions

- Workpiece mass: 1 [kg] • Workpiece mounting condition:
- Speed: 220 [mm/s]
- Mounting orientation: Vertical
- Stroke: 50 [mm]
- Acceleration/Deceleration: 5000 [mm/s²]
- Cycle time: 0.5 seconds

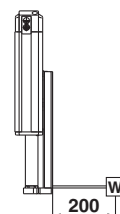

LESH16□/Step Motor Vertical

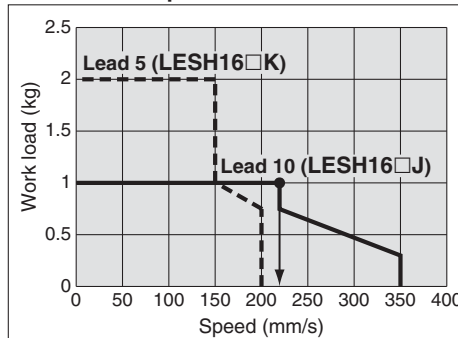

<Speed-Work load graph>

LESH16□/Step Motor

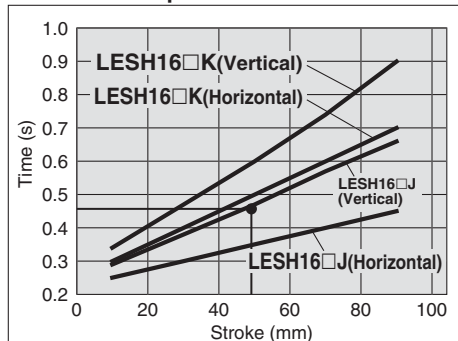

<Cycle time> LESH16/Pitching

Step 3 Confirmation of allowable moment <Static allowable moment> (Page 3)

<Dynamic allowable moment> (Page 4)

Please confirm the moment that applies to the actuator is within the allowable range for both static and dynamic conditions.

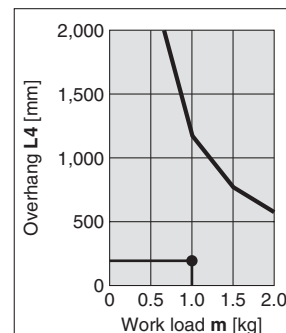
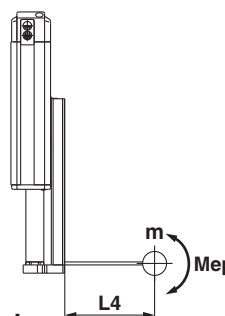

<Dynamic allowable moment>

Based on the above calculation result, the LESH16□J-50 is selected.

Speed-Work Load Graph (Guide)

Step Motor (Servo/24 VDC)

* The following graph shows the values when positioning force is 100%.

LESH8□

Horizontal

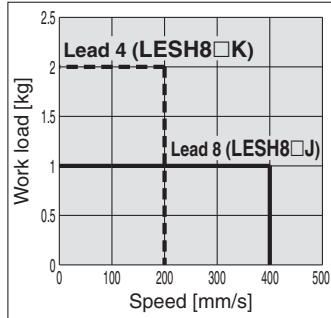

Vertical

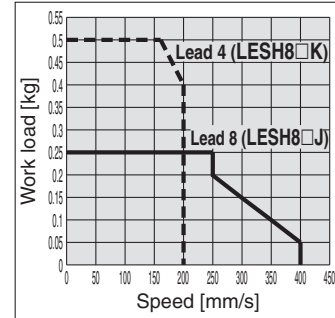

Servo Motor (24 VDC)

* The following graph shows the values when positioning force is 250%.

LESH8□A

Horizontal

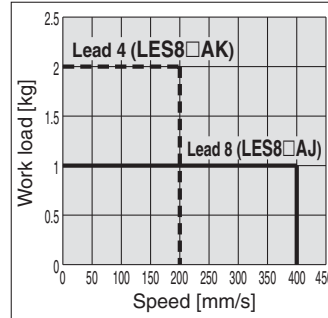

Vertical

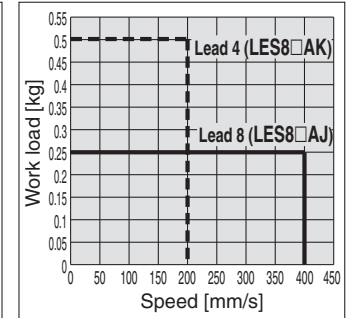

LESH16□

Horizontal

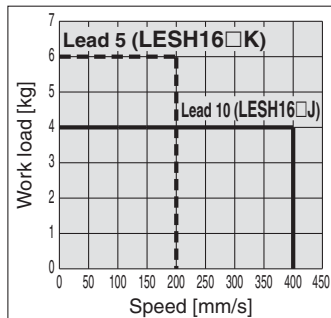

Vertical

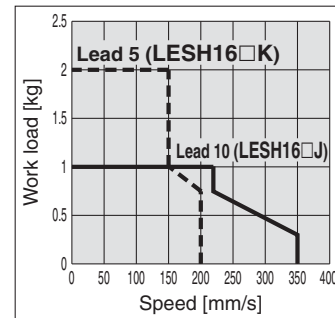

LESH16□A

Horizontal

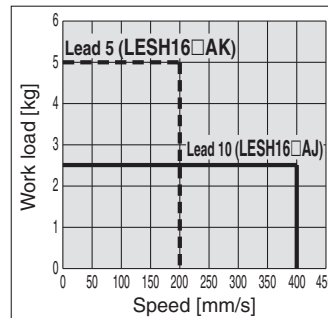

Vertical

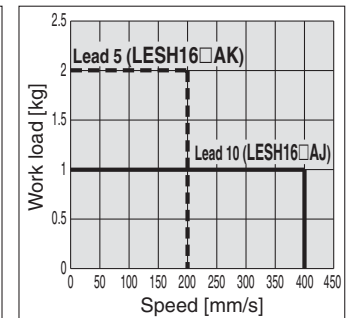

LESH25□

Horizontal

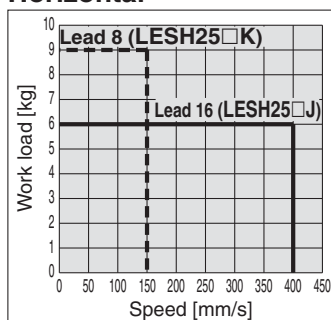

Vertical

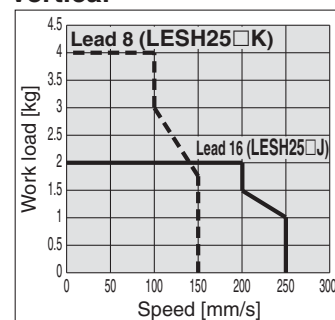

LESH25^R□A

Horizontal

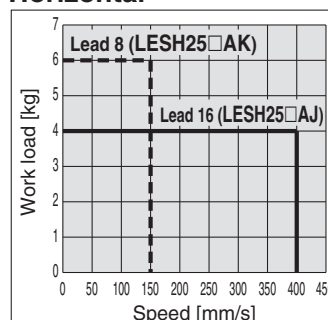

Vertical

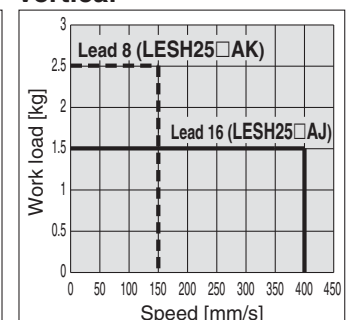

Servo Motor (24 VDC)/Step Motor (Servo/24 VDC)

LES

LECA6 / LECP6

LECP1

Specific Product Precautions

Series LES

Cycle Time (Guide)

Step Motor (Servo/24 VDC)

LESH8□

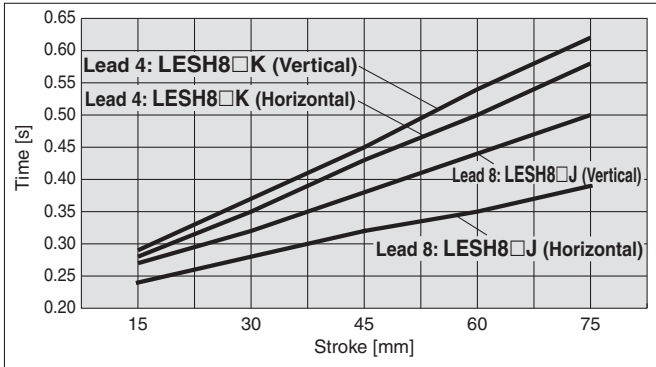

LESH16□

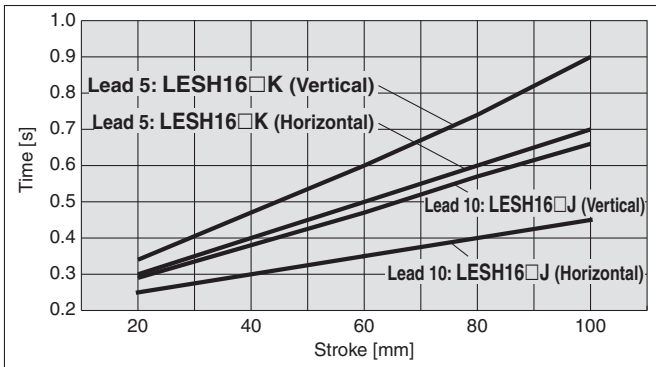

LESH25□

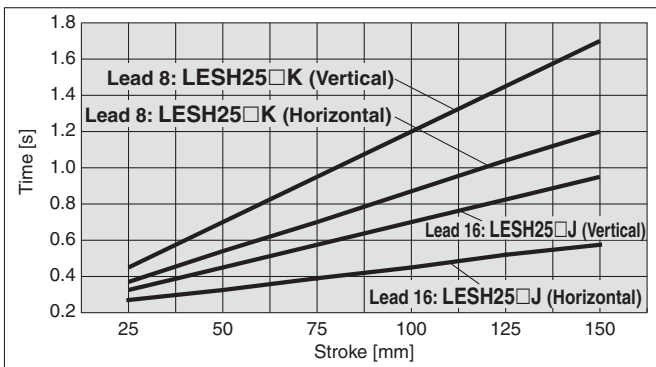

Servo Motor (24 VDC)

LESH8□A

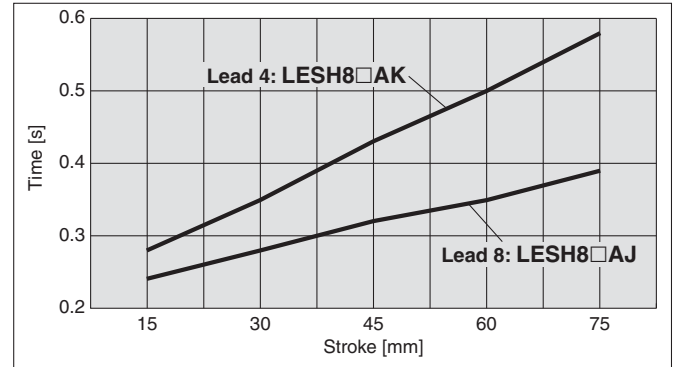

LESH16□A

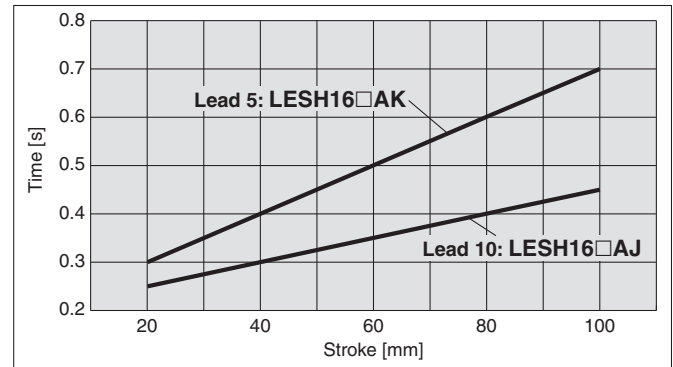

LESH25^R□A

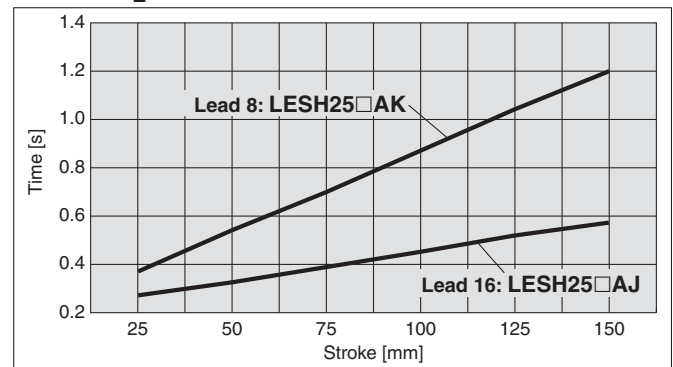

Operating Conditions

Workpiece mass: Max. load
 Speed : Max. speed
 Acceleration/
 Deceleration : 5000 mm/s²
 In position : 0.5

Dynamic Allowable Moment

Model		LESH8		LESH16		LESH25		
Stroke	[mm]	50	75	50	100	50	100	150
Pitching	[N·m]	11		26	43	77	112	155
Yawing	[N·m]	11						
Rolling	[N·m]	12		48		146	177	152

Dynamic Allowable Moment

* This graph shows the amount of allowable overhang when the centre of gravity of the workpiece overhangs in one direction. When the centre of gravity of the workpiece overhangs in two directions, refer to the Electric Actuator Selection Software for confirmation. <http://www.smcworld.com>

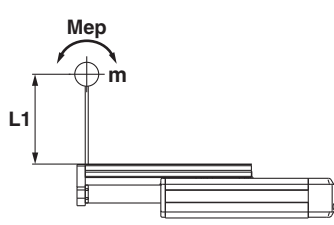
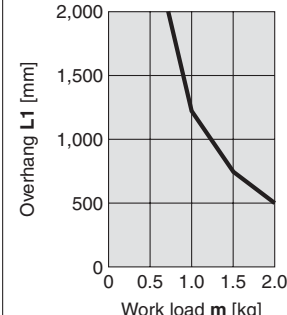
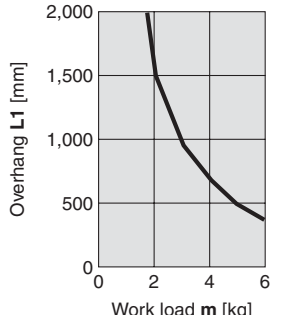
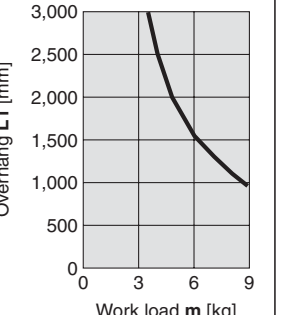
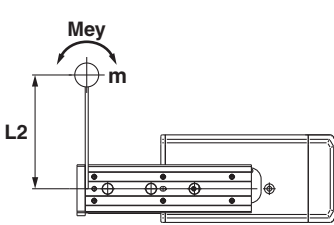
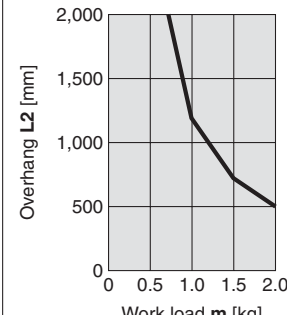
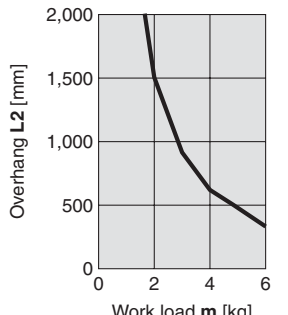
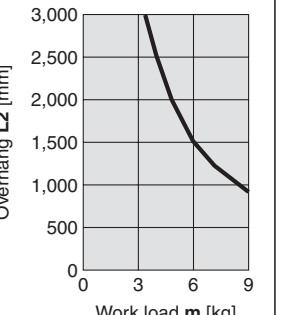
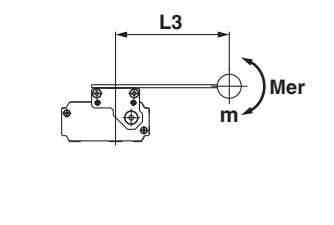
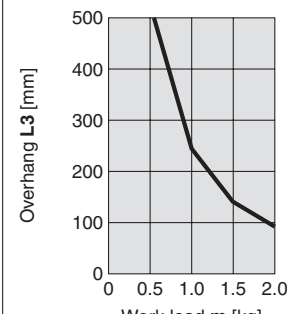
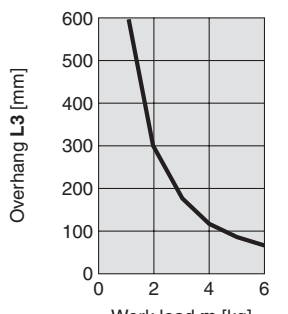
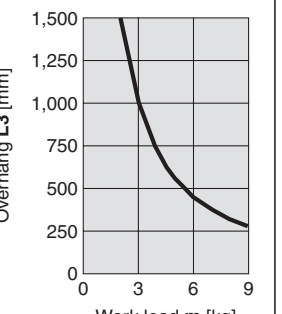
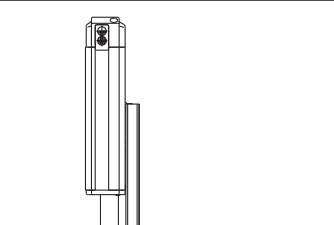
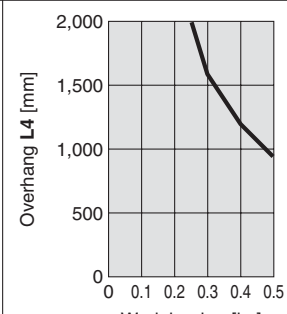
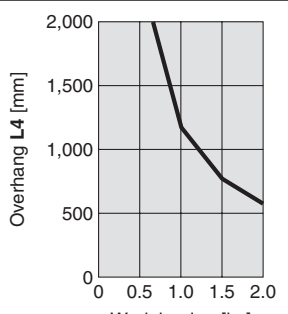
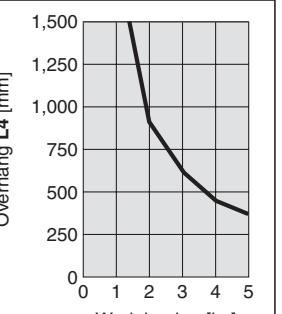
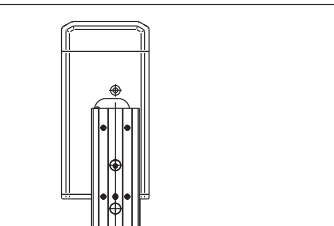
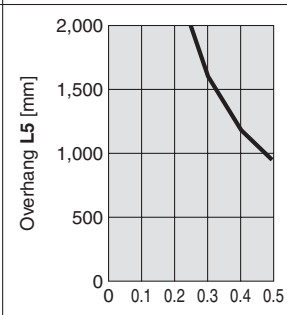
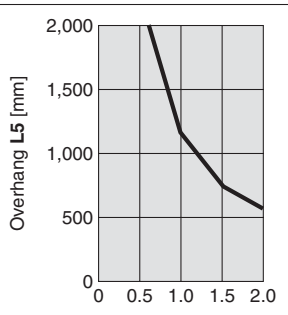
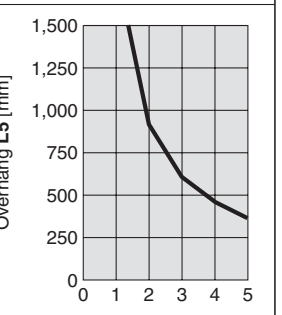
Orientation		Load overhanging direction m : Work load [kg] Me : Dynamic allowable moment [N·m] L : Amount of overhang to the centre of gravity of the workpiece [mm]	Model		
			LESH8	LESH16	LESH25
Horizontal	 <p>Pitching Mep</p>				
	 <p>Yawing Mey</p>				
	 <p>Rolling Mer</p>				
Vertical	 <p>Pitching Mep</p>				
	 <p>Yawing Mey</p>				

Model Selection 2



Selection Procedure

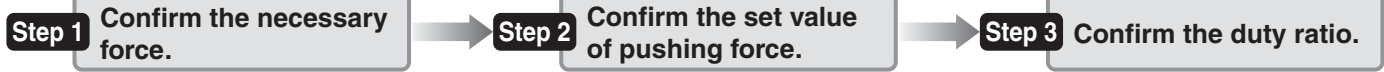

Selection Example

Operating conditions

- Pushing force: 90 N
- Workpiece mass: 1 kg
- Speed: 100 mm/s
- Stroke: 100 mm
- Mounting orientation: Vertical upward
- Pushing time + Operation (A): 1.5 seconds
- All cycle time (B): 6 seconds

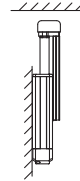

Step 1 Confirmation of necessary force

Calculate the rough necessary force for pushing operation.

Selection example) • Pushing force: 90 [N]
• Workpiece mass: 1 [kg]
Therefore the rough necessary force can be obtained as $90 + 10 = 100$ [N].

Refer to the product specifications (Pages 11 to 12) and select the target model based on the rough necessary force.

Selection example) Based on the specifications
• Rough necessary force: 100 [N]
• Speed: 100 [mm/s]
Therefore the LESH25□ is temporarily selected.

Then, calculate the necessary force for pushing operation. If the mounting position is vertical upward, please add the actuator table weight.

Selection example) Based on <Table weight>
• LESH25□ table weight: 1.3 [kg]
Therefore the necessary force can be obtained as $100 + 13 = 113$ [N].

Step 2 Confirmation of value of pushing force

<Set value of pushing force–Force graph> (Page 6)

Refer to <Set value of pushing force–Force graph> and select the target model based on the necessary force before confirming the set value of pushing force.

• Necessary force: 113 [N]
Therefore the LESH25□K is temporarily selected.
This set value of pushing force is 40 [%].

Step 3 Confirmation of duty ratio

Refer to <Allowable duty ratio> and confirm the allowable duty ratio based on set value of pushing force.

Selection example) Based on <Allowable duty ratio>
• Set value of pushing force: 40 [%]
Therefore the allowable duty ratio can be obtained as 30 [%].

Calculate the duty ratio for operating conditions and confirm it does not exceed the allowable duty ratio.

Selection example) • Pushing time + Operation (A): 1.5 seconds
• All cycle time (B): 6 seconds
Therefore the duty ratio can be obtained as $1.5/6 \times 100 = 25$ [%] and this will be the allowable range.

Based on the above calculation result, the LESH25□K-100 is selected. The allowable moment should follow the selection of the positioning control.

Table Weight

Model	Stroke [mm]			
	50	75	100	150
LESH8	0.2	0.3	—	—
LESH16	0.4	—	0.7	—
LESH25	0.9	—	1.3	1.7

* If the mounting position is vertical upward, please add table weight.

LESH25□/Step Motor

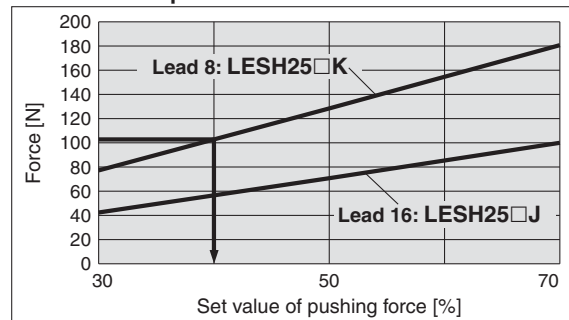

<Set value of pushing force–Force graph>

Allowable Duty Ratio

Step Motor (Servo/24 VDC)

Pushing force [%]	Duty ratio [%]	Continuous pushing time [min.]
30	—	—
50 or less	30 or less	5 or less
70 or less	20 or less	3 or less

Servo Motor (24 VDC)

Pushing force [%]	Duty ratio [%]	Continuous pushing time [min.]
50	—	—
75 or less	30 or less	5 or less
100 or less	20 or less	3 or less

* The pushing force of the LESH8□A is 75% at a maximum.

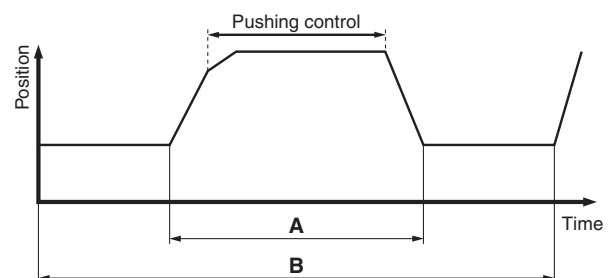

Set Value of Pushing Force–Force Graph

Step Motor (Servo/24 VDC)

LESH8□

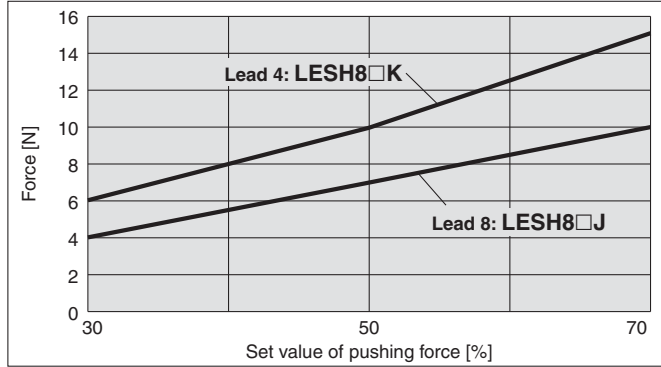

LESH16□

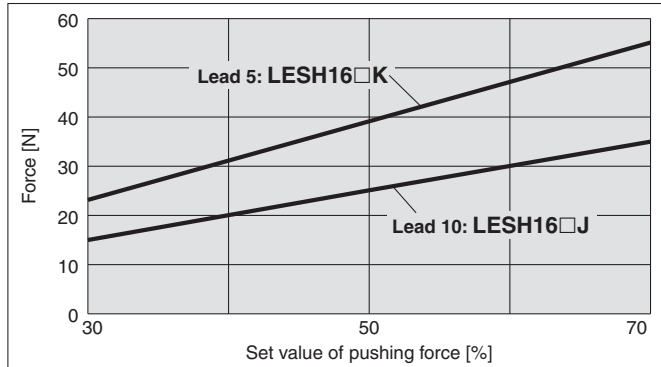

LESH25□

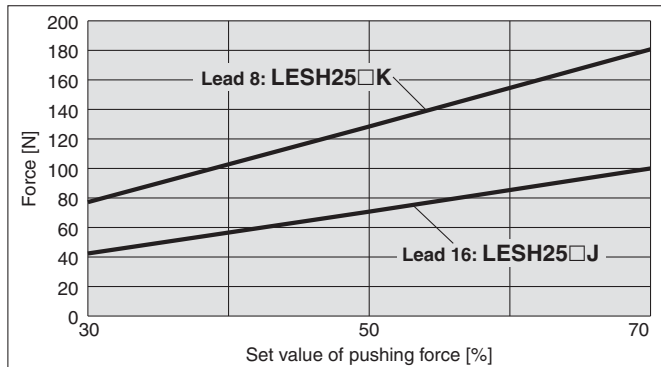

Servo Motor (24 VDC)

LESH8□A

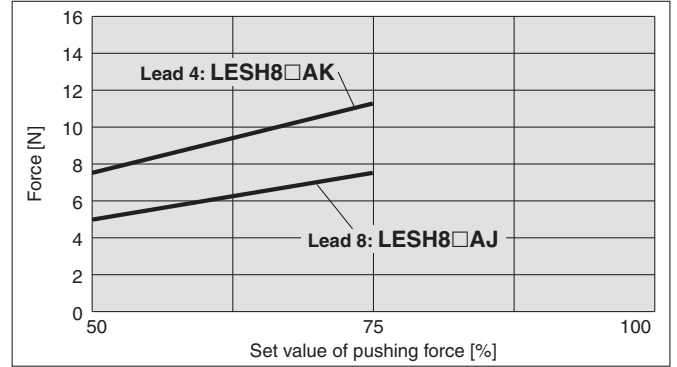

LESH16□A

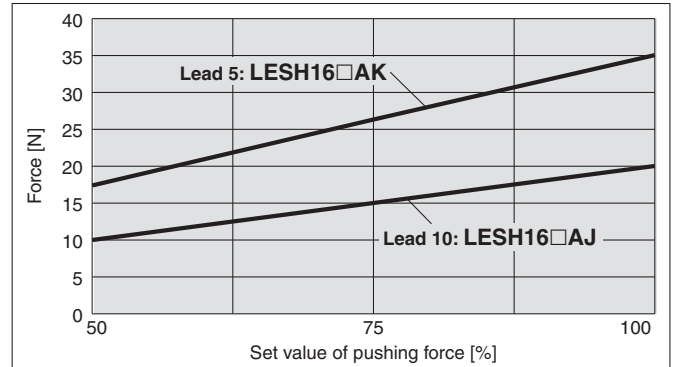

LESH25^R_LA

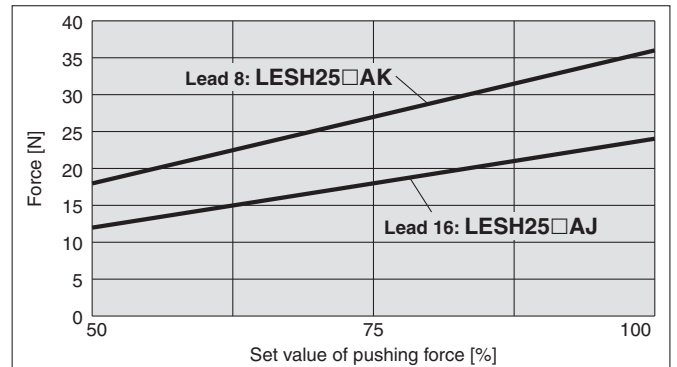
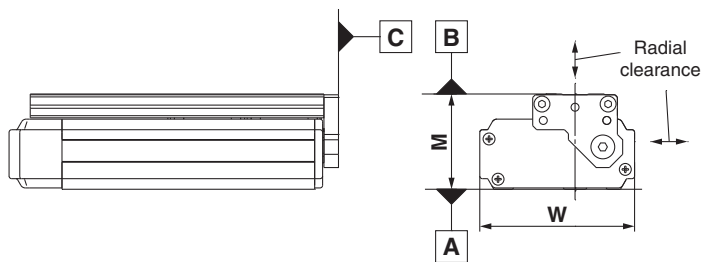

Table Accuracy

* These values are initial guideline values.



Model	LESH8	LESH16	LESH25
B side parallelism to A side	Refer to Table 1.		
B side traveling parallelism to A side	Refer to Graph 1.		
C side perpendicularity to A side	0.05	0.05	0.05
M dimension tolerance [mm]	±0.3		
W dimension tolerance [mm]	±0.2		
Radial clearance [μm]	-4 to 0	-10 to 0	-14 to 0

Table 1 B Side Parallelism to A Side

Model	Stroke [mm]			
	50	75	100	150
LESH8	0.055	0.065	—	—
LESH16	0.05	—	0.08	—
LESH25	0.06	—	0.08	0.125

Graph 1 B Side Traveling Parallelism to A Side

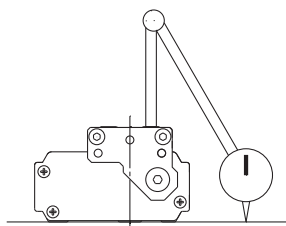
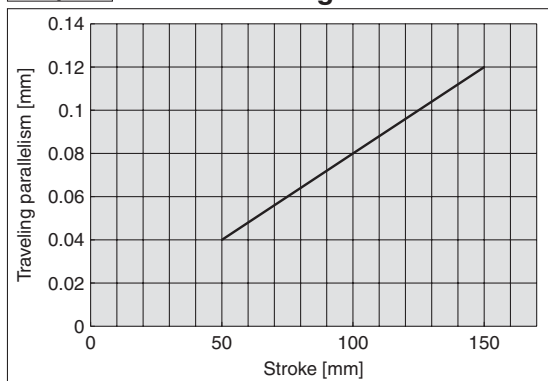

Traveling parallelism:
The amount of deflection on a dial gauge when the table travels a full stroke with the body secured on a reference base surface

Table Deflection (Reference Values)

* These values are initial guideline values.

Table displacement due to pitch moment load
Table displacement when loads are applied to the section marked with the arrow at the full stroke.

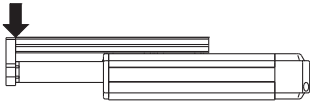

LESH8

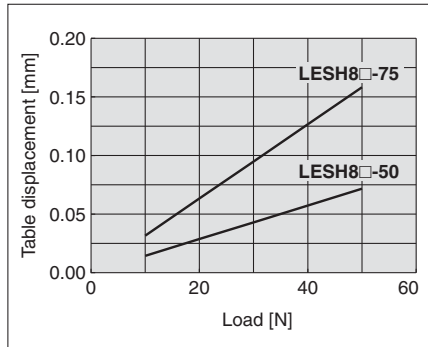

LESH16

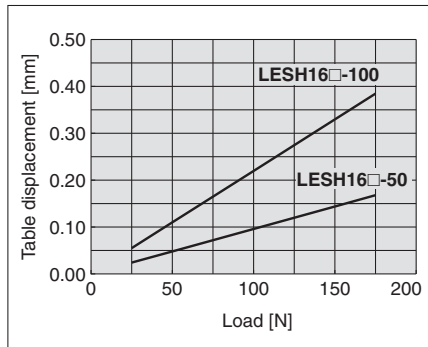

LESH25

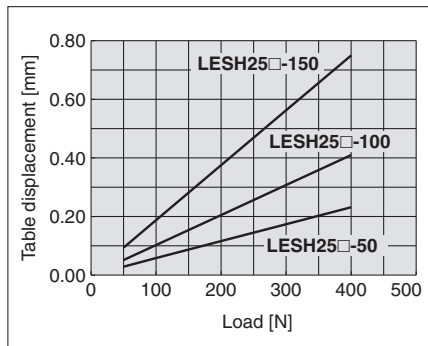
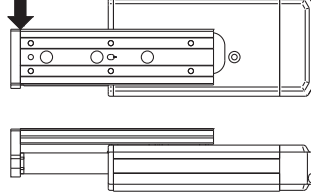
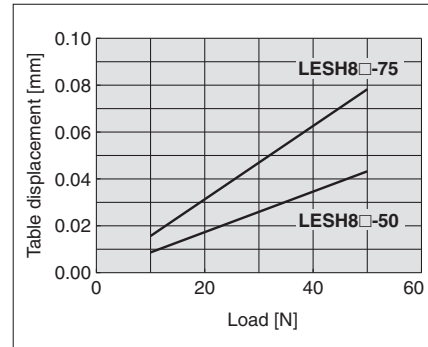

Table displacement due to pitch moment load
Table displacement when loads are applied to the section marked with the arrow at the full stroke.



LESH8



LESH16

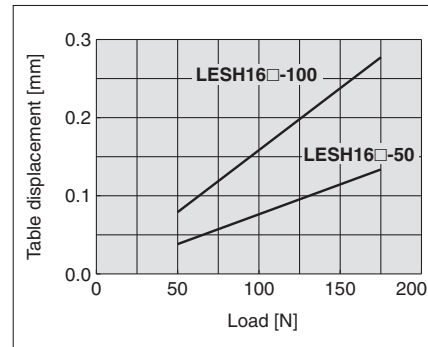

LESH25

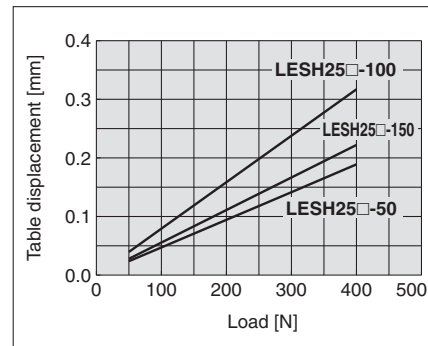
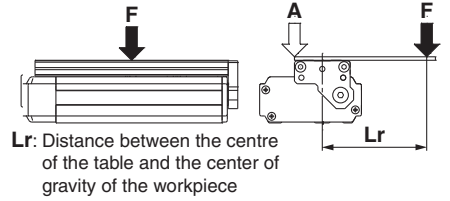

Table displacement due to roll moment load
Table displacement of section A when loads are applied to the section F with the slide table retracted.



Lr: Distance between the centre of the table and the center of gravity of the workpiece

LESH8

Lr = 70 mm

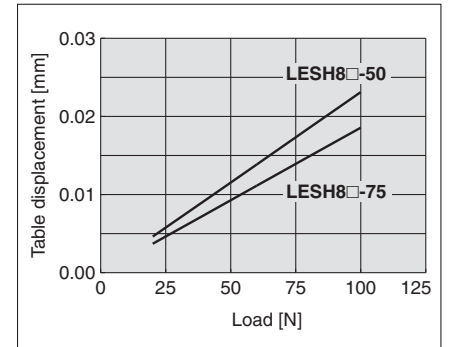

LESH16

Lr = 120 mm

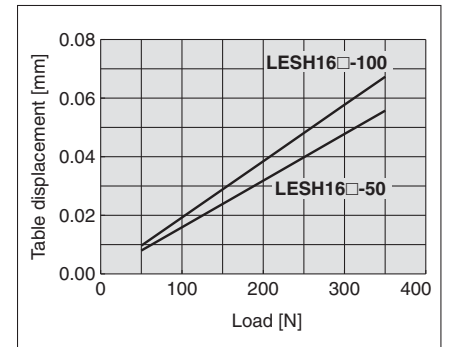

LESH25

Lr = 200 mm

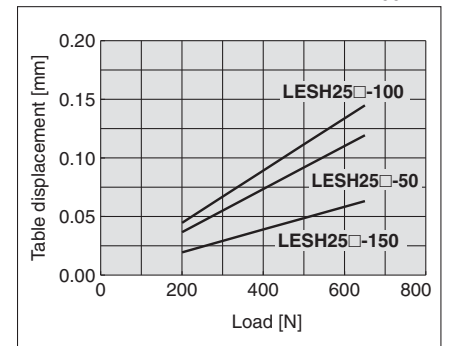

Servo Motor (24 VDC)/Step Motor (Servo/24 VDC)

LES

LECA6 / LECP6

LECP1

Specific Product Precautions

Electric Slide Table

Step Motor (Servo/24 VDC)

Servo Motor (24 VDC)

Series LES

LESH8, 16, 25



How to Order

LESH **8** **R** **J** - **50** **1** **6P** **1**

① ② ③ ④ ⑤ ⑥ ⑦ ⑧ ⑨ ⑩ ⑪ ⑫ ⑬

① Size

8
16
25

② Motor mounting position

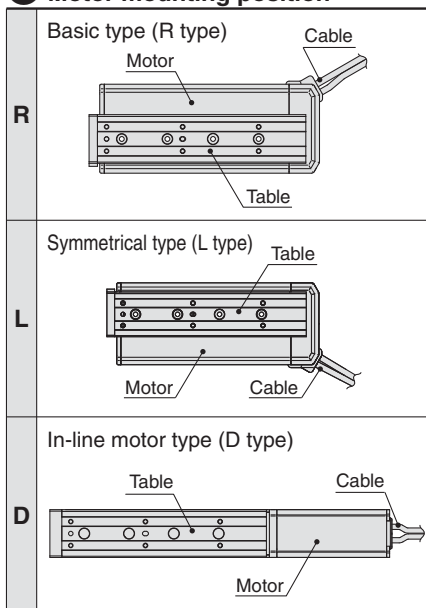

③ Motor type

Symbol	Motor type	Compatible controllers
—	Step motor (Servo/24 VDC)	LECP6 LECP1
A	Servo motor *1,2 (24 VDC)	LECP6

⚠ Caution

- *1 CE-compliant products
- ① EMC compliance was tested by combining the electric actuator LES series and the controller LEC series. The EMC depends on the configuration of the customer's control panel and the relationship with other electrical equipment and wiring. Therefore conformity to the EMC directive cannot be certified for SMC components incorporated into the customer's equipment under actual operating conditions. As a result it is necessary for the customer to verify conformity to the EMC directive for the machinery and equipment as a whole.
- ② For the servo motor (24 VDC) specification, EMC compliance was tested by installing a noise filter set (LEC-NFA). Refer to page 37 for the noise filter set. Refer to the LECA Operation Manual for installation.
- *2 LESH25DA is not available.

④ Lead [mm]

Symbol	LESH8	LESH16	LESH25
K	4	5	8
J	8	10	16

⑤ Stroke [mm]

Model	Stroke			
	50	75	100	150
LESH8	●*	●		
LESH16	●*		●	
LESH25	●		●	●

* For R/L type, 50 stroke with lock is not available.

⑥ Motor option

—	Without lock
B	With lock

The actuator and controller are sold as a package. (Controller → Pages 29 and 41)

Confirm that the combination of the controller and the actuator is correct.

<Check the following before use.>

- Check that the actuator label for model number. Matches the controller label.
- Check that the Parallel I/O configuration matches (NPN or PNP).

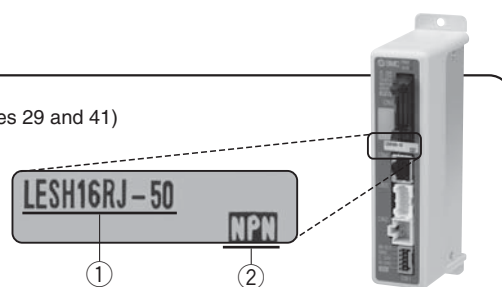

* Refer to the operation manual for using the products. Please download it via our website. <http://www.smcworld.com>



Basic type (R type)



Symmetrical type (L type)



In-line motor type (D type)

7 Body option

—	Basic type
S	Dustproof specification*

* For R/L type, a scraper is mounted on the rod cover, and gaskets are mounted on both the end covers. For D type, a scraper is mounted on the rod cover.

8 Mounting*

Symbol	Mounting type	R type L type	D type
—	Without side holder	●	●
H	With side holder (4 pcs.)	—	●

* Refer to page 24 for details.

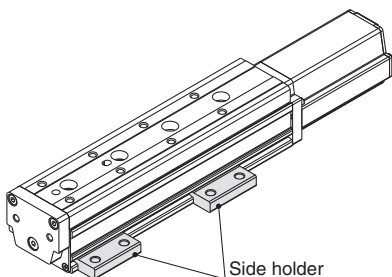

9 Actuator cable type *1

—	Without cable
S	Standard cable *2
R	Robotic cable (Flexible cable)

*1 The standard cable should be used on fixed parts. For using on moving parts, select the robotic cable.

*2 Only available for the motor type "Step motor."

10 Actuator cable length [m]

—	Without cable
1	1.5
3	3
5	5
8	8*
A	10*
B	15*
C	20*

* Produced upon receipt of order (Robotic cable only). Refer to the specifications Note 3) on page 11.

11 Controller type *1

6N	LECP6/LECA6 (Step data input type)	NPN
6P		PNP
1N	LECP1 *2 (Programless type)	NPN
1P		PNP

*1 Refer to pages 29 and 41 for the detailed specifications of the controller itself.

*2 Only available for the motor type "Step motor."

12 I/O cable length [m]

—	Without cable
1	1.5*
3	3*
5	5*

* If "Without controller" is selected for controller types, I/O cable is not included. Refer to page 37 (LECP6/LECA6) or page 47 (LECP1) if I/O cable is required.

13 Controller mounting

—	Screw mounting
D	DIN rail mounting *1, 2

*1 Only available for the controller types "6N" and "6P."

*2 DIN rail is not included. Order it separately.

Compatible controllers

Type	Step data input type	Step data input type	Programless type
Series	LECP6	LECA6	LECP1
Feature(s)	Value input Standard controller		Capable of setting up operation without using a PC or teaching box
Compatible motor	Step motor (Servo/24 VDC)	Servo motor (24 VDC)	Step motor (Servo/24 VDC)
Maximum number of step data	64 points		14 points
Power supply voltage	24 VDC		
Reference page	Page 29	Page 29	Page 41

Series LES

Specifications

Step Motor (Servo/24 VDC)

Model		LESH8□		LESH16□		LESH25□		
Actuator specifications	Stroke [mm]	50, 75		50, 100		50, 100, 150		
	Work load [kg] <small>Note 1) Note 3)</small>	Horizontal	2	1	6	4	9	6
		Vertical	0.5	0.25	2	1	4	2
	Pushing force [N] 30% to 70% <small>Note 2) Note 3)</small>	6 to 15	4 to 10	23.5 to 55	15 to 35	77 to 180	43 to 100	
	Speed [mm/s] <small>Note 1) Note 3)</small>	10 to 200	20 to 400	10 to 200	20 to 400	10 to 150	20 to 400	
	Pushing speed [mm/s]	10 to 20	20	10 to 20	20	10 to 20	20	
	Max. acceleration/deceleration [mm/s ²]	5000						
	Positioning repeatability [mm]	±0.05						
	Screw lead [mm]	4	8	5	10	8	16	
	Impact/Vibration resistance [m/s ²] <small>Note 4)</small>	50/20						
	Actuation type	Slide screw + Belt (R/L type), Slide screw (D type)						
	Guide type	Linear guide (Circulating type)						
	Operating temp. range [°C]	5 to 40						
Operating humidity range [%RH]	90 or less (No condensation)							
Electric specifications	Motor size	□20		□28		□42		
	Motor type	Step motor (Servo/24 VDC)						
	Encoder	Incremental A/B phase (800 pulse/rotation)						
	Rated voltage [V]	24 VDC ±10%						
	Power consumption [W] <small>Note 5)</small>	20		43		67		
	Standby power consumption when operating [W] <small>Note 6)</small>	7		15		13		
	Momentary max. power consumption [W] <small>Note 7)</small>	35		60		74		
	Controller weight [kg]	Step data input type: 0.15 (Screw mounting), 0.17 (DIN rail mounting)/Programless type: 0.13						
Lock unit specifications	Type	Non-magnetizing operation type						
	Holding force [N]	24	2.5	300	48	500	77	
	Power consumption [W] <small>Note 9)</small>	4		3.6		5		
	Rated voltage [V]	24 VDC ±10%						

Note 1) Speed is dependent on the work load. Check "Speed-Work Load Graph (Guide)" on page 2.

Note 2) Pushing force accuracy is ±20% (F.S.).

Note 3) The speed and force may change depending on the cable length, load and mounting conditions. Furthermore, if the cable length exceeds 5 m then it will decrease by up to 10% for each 5 m. (At 15 m: Reduced by up to 20%)

Note 4) Vibration resistance: No malfunction occurred in a test ranging between 45 to 2000 Hz. Test was performed in both an axial direction and a perpendicular direction to the lead screw. (Test was performed with the slide table in the initial state.)

Impact resistance: No malfunction occurred when the slide table was tested with a drop tester in both an axial direction and a perpendicular direction to the lead screw. (Test was performed with the slide table in the initial state.)

Note 5) Power consumption (including the controller) is for when the actuator is operating.

Note 6) Standby power consumption when operating (including the controller) is for when the actuator is stopped in the set position during operation, except during pushing operation.

Note 7) Momentary max. power consumption (including the controller) is for when the actuator is operating. This value can be used for the selection of the power supply.

Note 8) With lock only

Note 9) For an actuator with lock, add the power consumption for the lock.

Specifications

Servo Motor (24 VDC)

Model		LESH8□A		LESH16□A		LESH25 ^R A ^{Note 1)}		
Actuator specifications	Stroke [mm]	50, 75		50, 100		50, 100, 150		
	Work load [kg]	Horizontal	2	1	5	2.5	6	4
		Vertical	0.5	0.25	2	1	2.5	1.5
	Pushing force [N] 50% to 100% ^{Note 2)}	7.5 to 11	5 to 7.5	17.5 to 35	10 to 20	18 to 36	12 to 24	
	Speed [mm/s]	10 to 200	20 to 400	10 to 200	20 to 400	10 to 150	20 to 400	
	Pushing speed [mm/s] ^{Note 2)}	10 to 20	20	10 to 20	20	10 to 20	20	
	Max. acceleration/deceleration [mm/s ²]	5000						
	Positioning repeatability [mm]	±0.05						
	Screw lead [mm]	4	8	5	10	8	16	
	Impact/Vibration resistance [m/s ²] ^{Note 3)}	50/20						
	Actuation type	Slide screw + Belt (R/L type), Slide screw (D type)						
	Guide type	Linear guide (Circulating type)						
Operating temp. range [°C]	5 to 40							
Operating humidity range [%RH]	90 or less (No condensation)							
Electric specifications	Motor size	□20		□28		□42		
	Motor output [W]	10		30		36		
	Motor type	Servo Motor (24 VDC)						
	Encoder	Incremental A/B/Z phase (800 pulse/rotation)						
	Rated voltage [V]	24 VDC ±10%						
	Power consumption [W] ^{Note 4)}	58		84		144		
	Standby power consumption when operating [W] ^{Note 5)}	4 (Horizontal)/7 (Vertical)		2 (Horizontal)/15 (Vertical)		4 (Horizontal)/43 (Vertical)		
	Momentary max. power consumption [W] ^{Note 6)}	84		124		158		
	Controller weight [kg]	Step data input type: 0.15 (Screw mounting), 0.17 (DIN rail mounting)/Programless type: 0.13						
	Type	Non-magnetizing operation type						
Lock unit specifications	Holding force [N]	24	2.5	300	48	500	77	
	Power consumption [W] ^{Note 8)}	4		3.6		5		
	Rated voltage [V]	24 VDC ±10%						

Note 1) LESH25DA is not available.

Note 2) For LESH8□A, the pushing force range is 50 to 75%. Pushing force accuracy is ±20% (F.S.).

Note 3) Vibration resistance: No malfunction occurred in a test ranging between 45 to 2000 Hz. Test was performed in both an axial direction and a perpendicular direction to the lead screw. (Test was performed with the slide table in the initial state.)

Impact resistance: No malfunction occurred when the slide table was tested with a drop tester in both an axial direction and a perpendicular direction to the lead screw. (Test was performed with the slide table in the initial state.)

Note 4) Power consumption (including the controller) is for when the actuator is operating.

Note 5) Standby power consumption when operating (including the controller) is for when the actuator is stopped in the set position during operation, except during pushing operation.

Note 6) Momentary max. power consumption (including the controller) is for when the actuator is operating. This value can be used for the selection of the power supply.

Note 7) With lock only

Note 8) For an actuator with lock, add the power consumption for the lock.

Note 9) Speed is dependent on the work load. Check "Speed-Work Load Graph (Guide)" on page 2.

Note 10) Pushing force accuracy is ±20% (F.S.).

Weight

Step Motor (Servo/24 VDC), Servo Motor (24 VDC) Common

Model		Basic type (R type)/Symmetrical type (L type)						In-line motor type (D type)							
		LESH8 ^R (A)		LESH16 ^R (A)		LESH25 ^R (A)		LESH8D(A)		LESH16D(A)		LESH25D			
Stroke [mm]		50	75	50	100	50	100	150	50	75	50	100	50	100	150
Product weight [kg]	Without lock	0.55	0.70	1.15	1.60	2.50	3.30	4.26	0.57	0.70	1.25	1.70	2.52	3.27	3.60
	With lock	—	0.79	—	1.71	2.84	3.64	4.60	0.66	0.79	1.36	1.81	2.86	3.61	3.94

Series LES

Construction: R/L Type

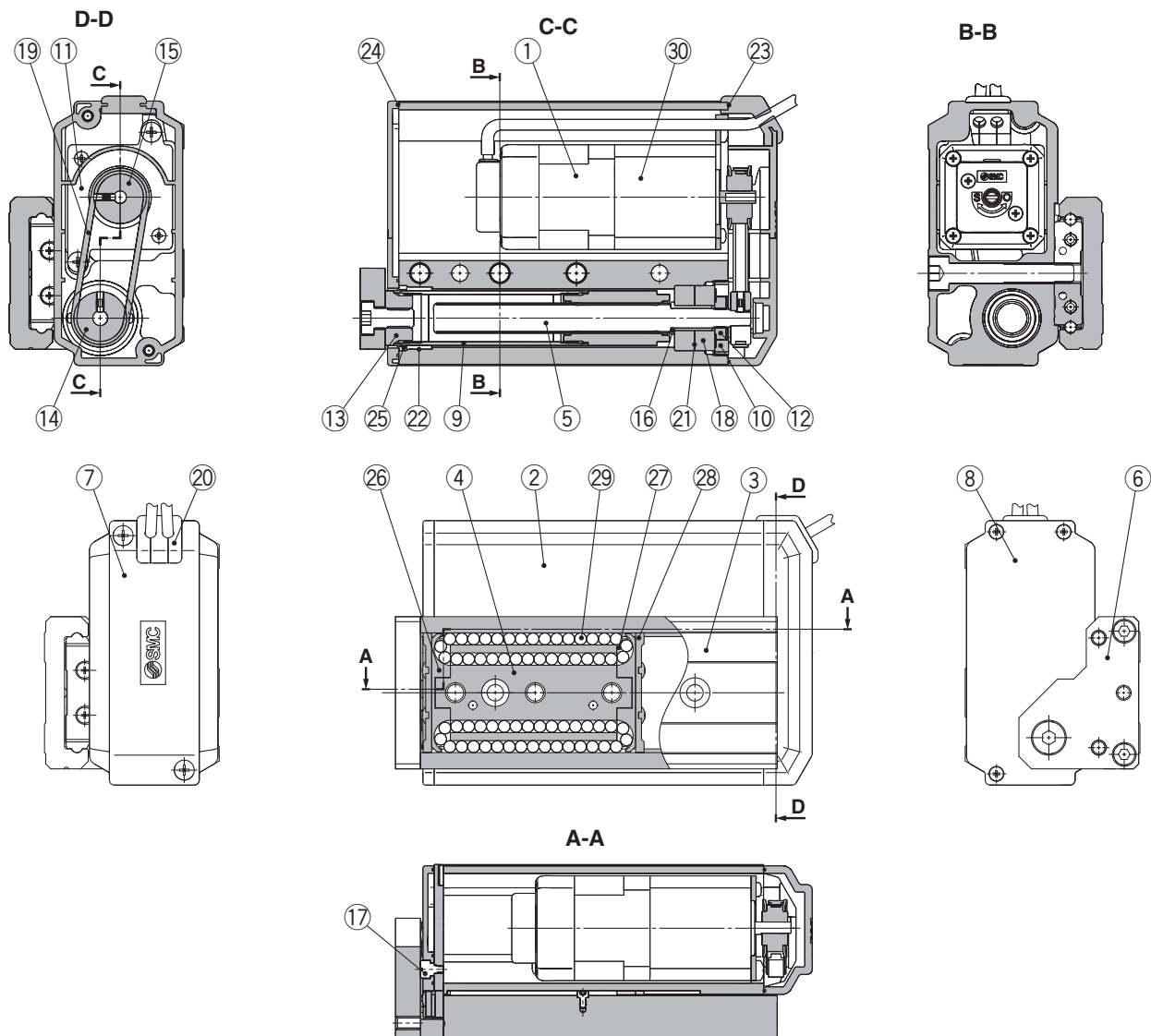

Component Parts

No.	Description	Material	Note
1	Motor	—	—
2	Body	Aluminium alloy	Anodised
3	Table	Stainless steel	Heat treatment + Electroless nickel plated
4	Guide block	Stainless steel	Heat treatment
5	Lead screw	Stainless steel	Heat treatment + Specially treated
6	End plate	Aluminium alloy	Anodised
7	Pulley cover	Synthetic resin	—
8	End cover	Synthetic resin	—
9	Rod	Stainless steel	—
10	Bearing stopper	Structural steel	Electroless nickel plated
11	Motor plate	Structural steel	—
12	Lock nut	Structural steel	Chromate treated
13	Socket	Structural steel	Electroless nickel plated
14	Lead screw pulley	Aluminium alloy	—
15	Motor pulley	Aluminium alloy	—
16	Spacer	Stainless steel	LESH25R/L□ only
17	Stopper	Structural steel	Electroless nickel plated
18	Bearing	—	—
19	Belt	—	—
20	Grommet	Synthetic resin	—
21	Sim ring	Structural steel	—

No.	Description	Material	Note
22	Bushing	—	Dustproof specification only
23	Pulley gasket	NBR	Dustproof specification only
24	End gasket	NBR	Dustproof specification only
25	Scraper	NBR	Only for dustproof specification/Rod
26	Cover	Synthetic resin	—
27	Return guide	Synthetic resin	—
28	Scraper	Stainless steel + NBR	Linear guide
29	Steel ball	Special steel	—
30	Lock	—	—

Replacement Parts/Belt

Size	Part no.
LESH8 ^R _L	LE-D-1-1
LESH16 ^R _L	LE-D-1-2
LESH25 ^R _L	LE-D-1-3

Replacement Parts/Grease Pack

Applied portion	Kit no.
Guide unit	GR-S-010 (10 g) GR-S-020 (20 g)

Construction: D Type

Model Selection

Servo Motor (24 VDC)/Step Motor (Servo/24 VDC)

LES

LECA6 / LECP6

LECP1

Specific Product Precautions

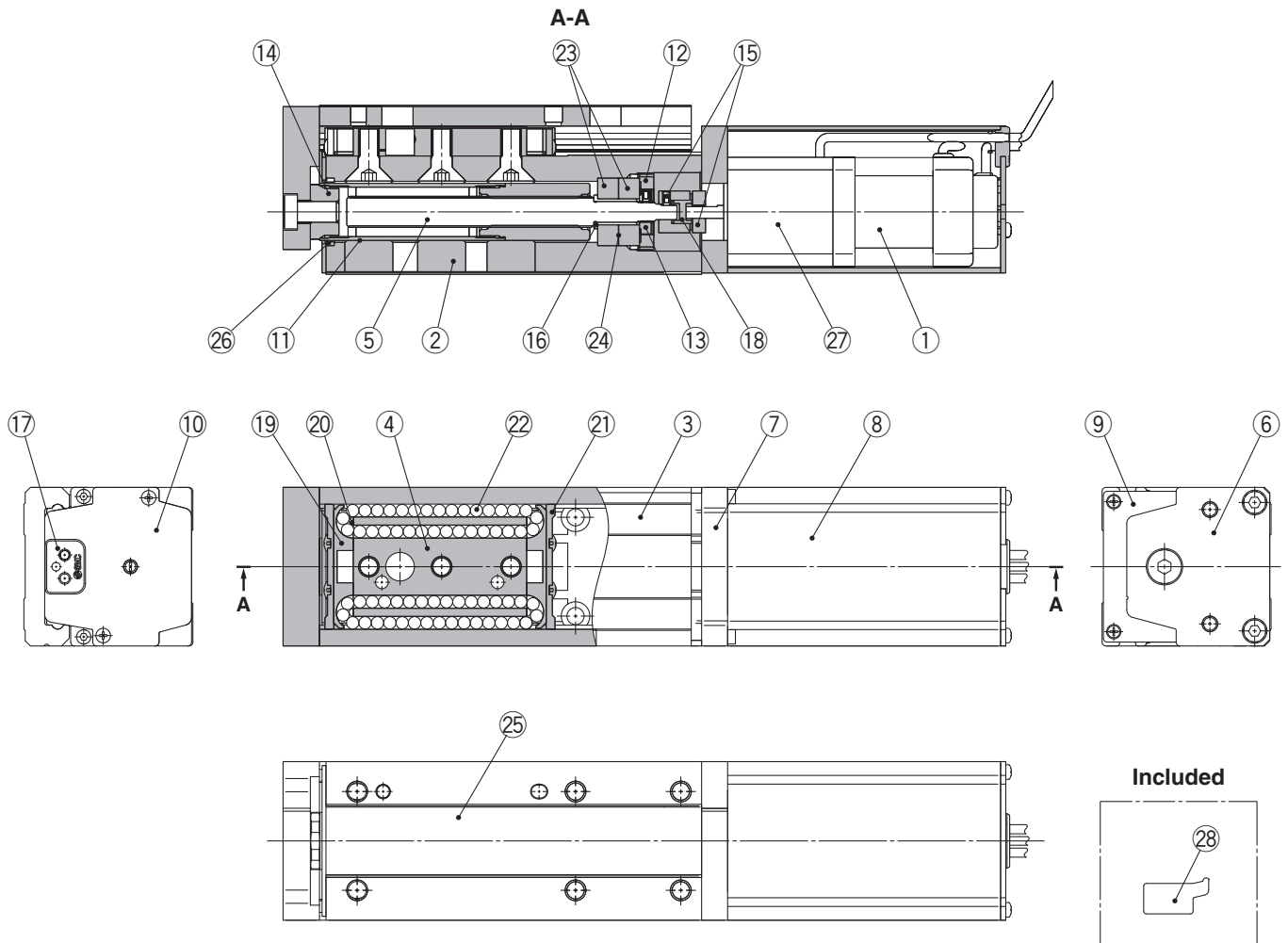

Component Parts

No.	Description	Material	Note
1	Motor	—	—
2	Body	Aluminium alloy	Anodised
3	Table	Stainless steel	Heat treatment + Electroless nickel plated
4	Guide block	Stainless steel	Heat treatment
5	Lead screw	Stainless steel	Heat treatment + Specially treated
6	End plate	Aluminium alloy	Anodised
7	Motor flange	Aluminium alloy	Anodised
8	Motor cover	Aluminium alloy	Anodised
9	End cover	Aluminium alloy	Anodised
10	Motor end cover	Aluminium alloy	Anodised
11	Rod	Stainless steel	—
12	Bearing holder	Structural steel	Electroless nickel plated
13	Lock nut	Structural steel	Chromate treated
14	Socket	Structural steel	Electroless nickel plated
15	Hub	Aluminium alloy	—
16	Spacer	Stainless steel	LESH25D□ only
17	Grommet	NBR	—
18	Spider	NBR	—
19	Cover	Synthetic resin	—
20	Return guide	Synthetic resin	—
21	Scraper	Stainless steel + NBR	Linear guide

No.	Description	Material	Note
22	Steel ball	Special steel	—
23	Bearing	—	—
24	Sim ring	Structural steel	—
25	Masking tape	—	—
26	Scraper	NBR	Only for dustproof specification/Rod
27	Lock	—	—
28	Side holder	Aluminium alloy	Anodised

Replacement Parts/Grease Pack

Applied portion	Kit no.
Guide unit	GR-S-010 (10 g) GR-S-020 (20 g)

Series LES

Dimensions: Basic Type (R Type)

LESH8R

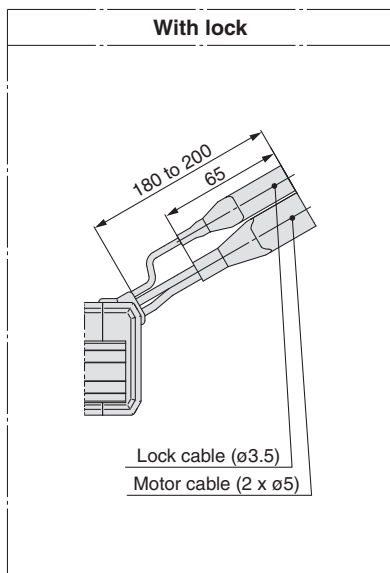
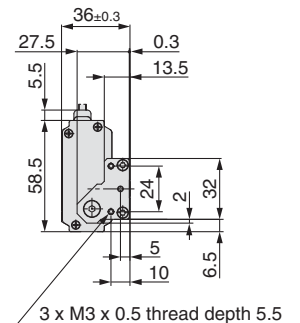
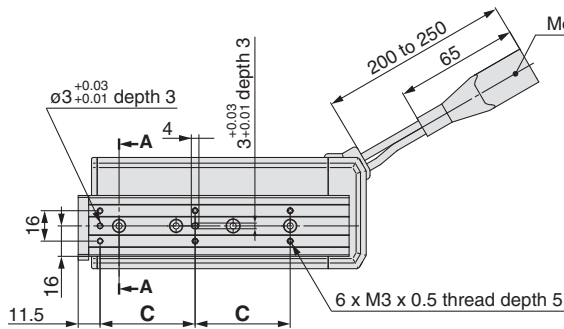
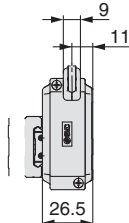
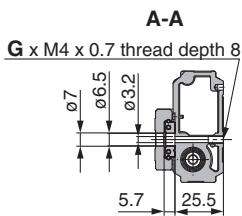
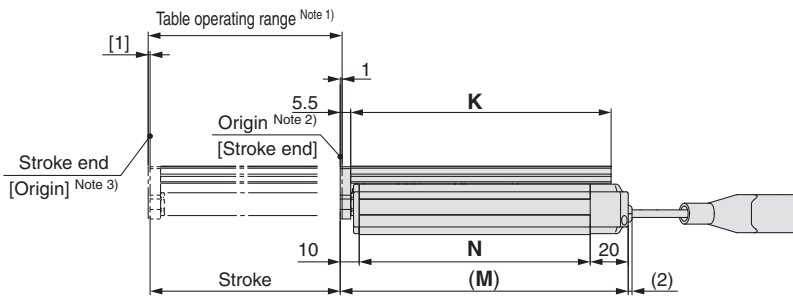
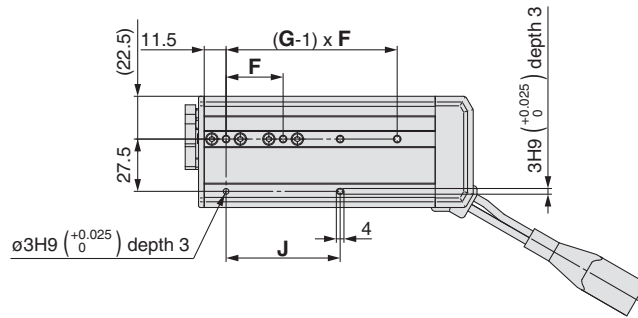

	Cable	
	Step motor	Servo motor
Motor cable		
Lock cable		

	[mm]						
Model	C	F	G	J	K	M	N
LESH8R□□-50□□-□□□□□□	46	29	3	58	111	125.5	95.5
LESH8R□□-75□□-□□□□□□	50	30	4	60	137	151.5	121.5

Note 1) Range within which the table can move when it returns to origin. Make sure a workpiece mounted on the table does not interfere with the work pieces and facilities around the table.

Note 2) Position after return to origin.

Note 3) The number in brackets indicates when the direction of return to origin has changed.

Dimensions: Basic Type (R Type)

LESH16R

Model Selection

Servo Motor (24 VDC)/Step Motor (Servo/24 VDC)

LES

LECA6 / LECP6

LECP1

Specific Product Precautions

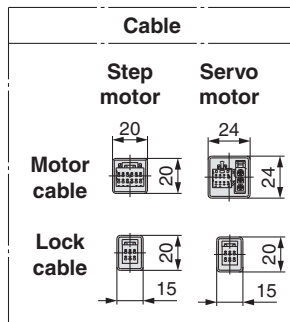
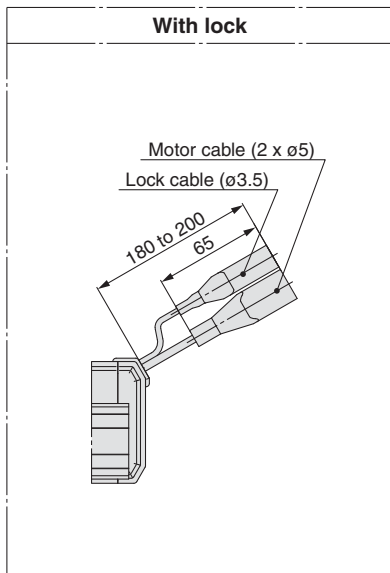
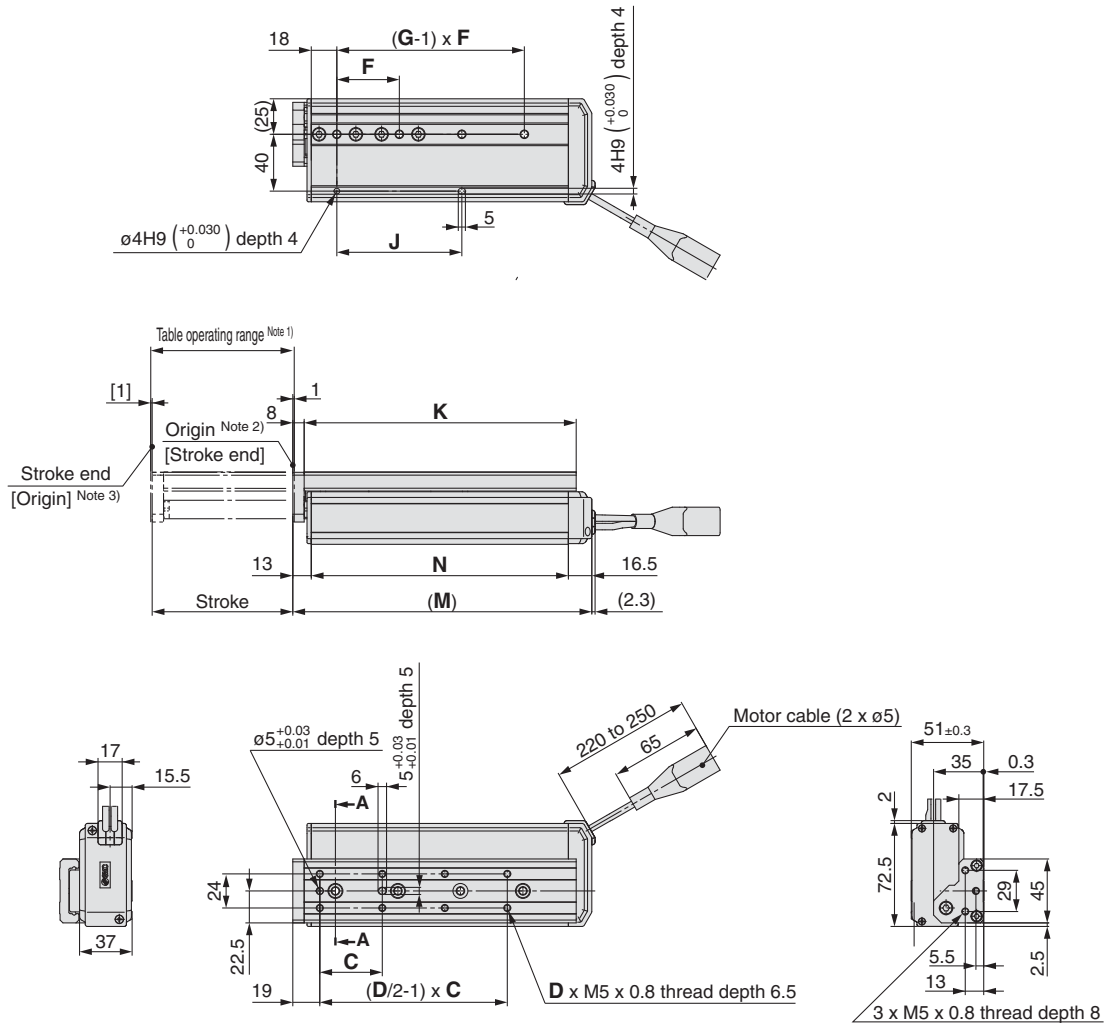

Model	C	D	F	G	J	K	M	N
LESH16R□□-50□□-□□□□□	40	6	45	2	45	116.5	135.5	106
LESH16R□□-100□□-□□□□□	44	8	44	4	88	191.5	210.5	181

Note 1) Range within which the table can move when it returns to origin. Make sure a workpiece mounted on the table does not interfere with the work pieces and facilities around the table.
 Note 2) Position after return to origin.
 Note 3) The number in brackets indicates when the direction of return to origin has changed.

Series LES

Dimensions: Basic Type (R Type)

LESH25R

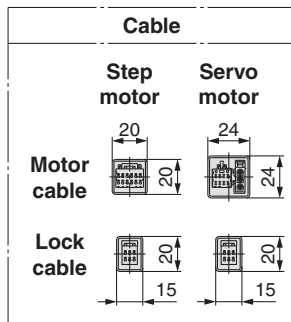
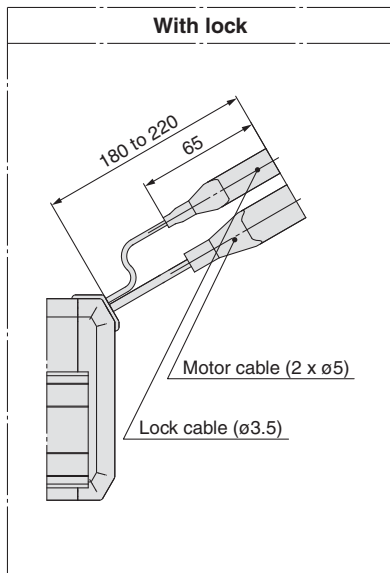
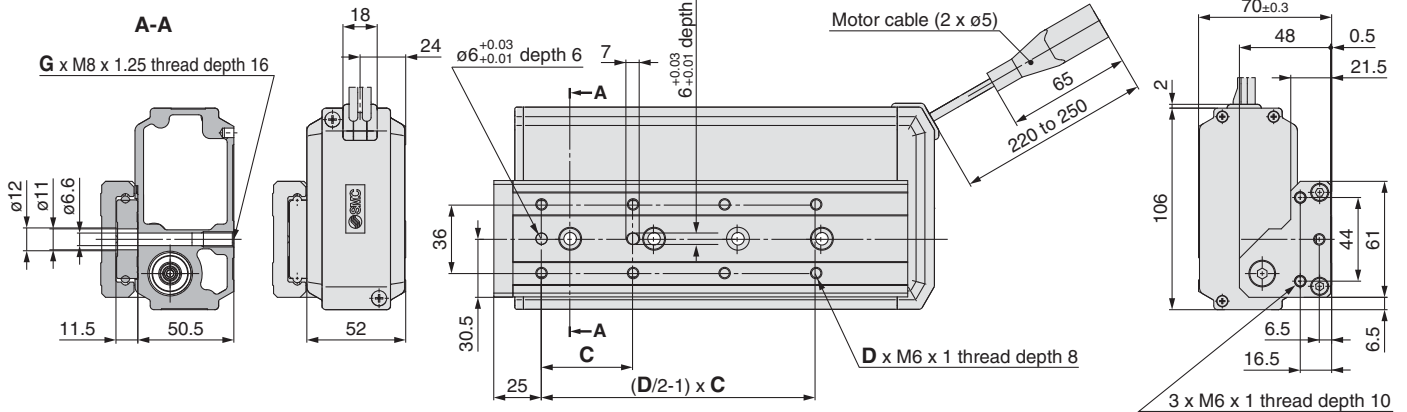
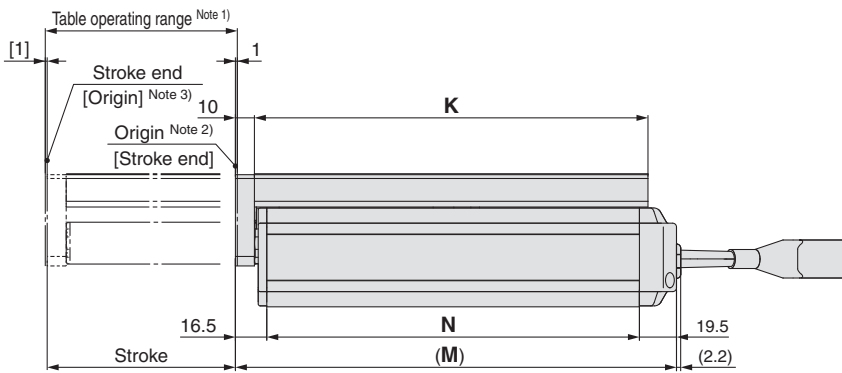
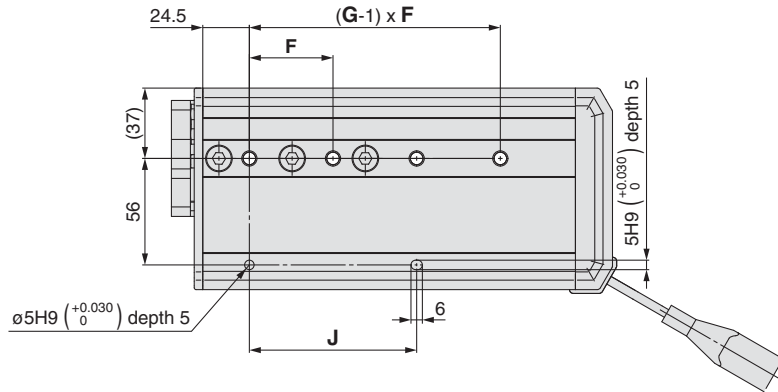

Model	C	D	F	G	J	K	M	N
LESH25R□□-50□□-□□□□□□	75	4	80	2	80	143	168	132
LESH25R□□-100□□-□□□□□□	48	8	44	4	88	207	232	196
LESH25R□□-150□□-□□□□□□	65	8	66	4	132	285	310	274

Note 1) Range within which the table can move when it returns to origin. Make sure a workpiece mounted on the table does not interfere with the work pieces and facilities around the table.

Note 2) Position after return to origin.

Note 3) The number in brackets indicates when the direction of return to origin has changed.

Dimensions: Symmetrical Type (L Type)

LESH8L

Model Selection

Servo Motor (24 VDC)/Step Motor (Servo/24 VDC)

LES

LECA6 / LECP6

LECP1

Specific Product Precautions

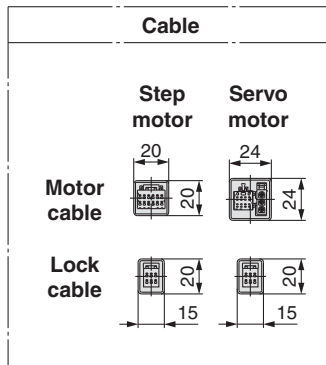
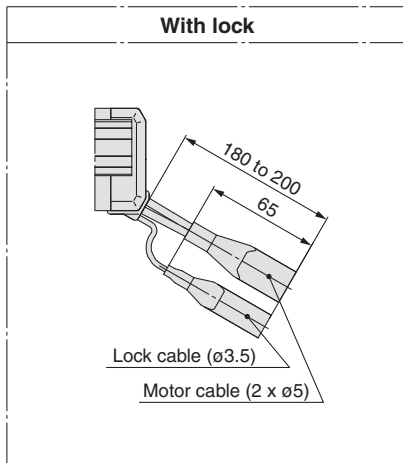
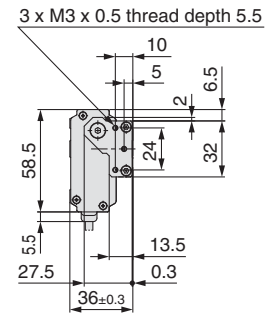
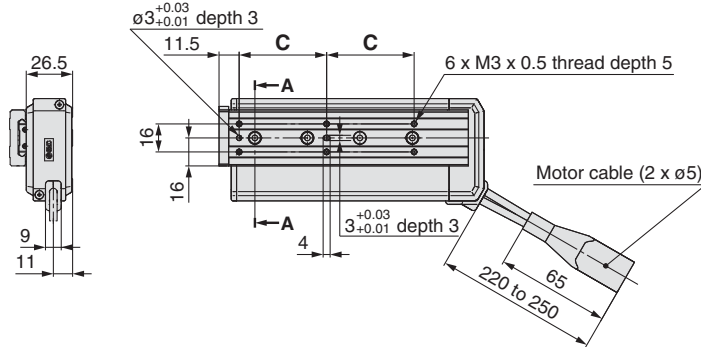
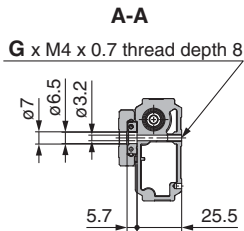
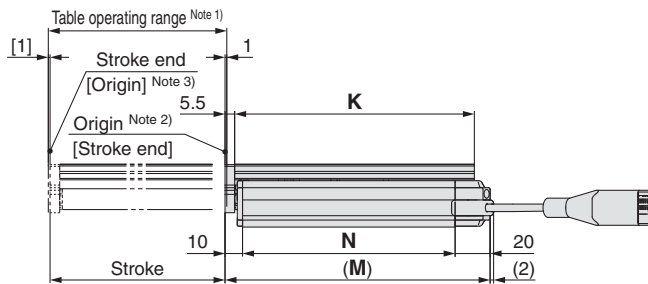
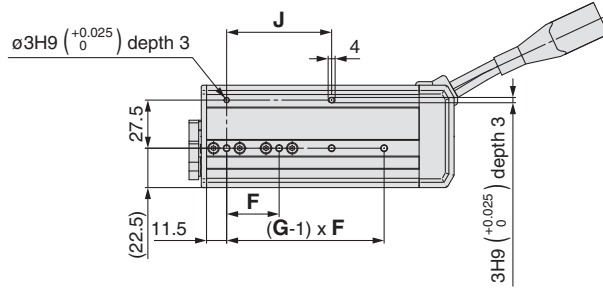

Model	C	F	G	J	K	M	N
LESH8L□□-50□□-□□□□□□	46	29	3	58	111	125.5	95.5
LESH8L□□-75□□-□□□□□□	50	30	4	60	137	151.5	121.5

Note 1) Range within which the table can move when it returns to origin. Make sure a workpiece mounted on the table does not interfere with the work pieces and facilities around the table.
 Note 2) Position after return to origin.
 Note 3) The number in brackets indicates when the direction of return to origin has changed.

Series LES

Dimensions: Symmetrical Type (L Type)

LESH16L

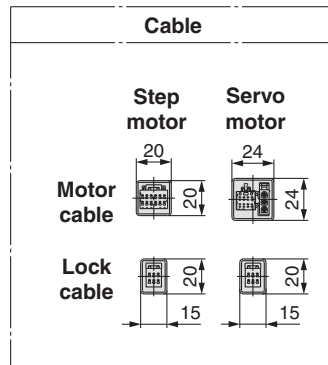
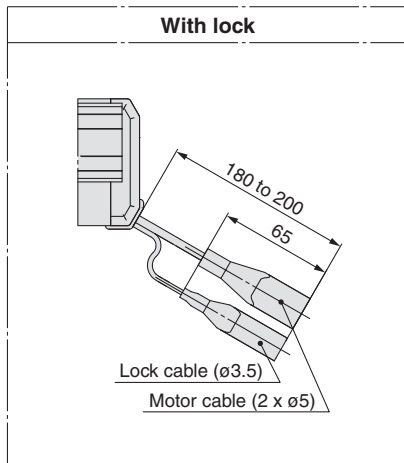
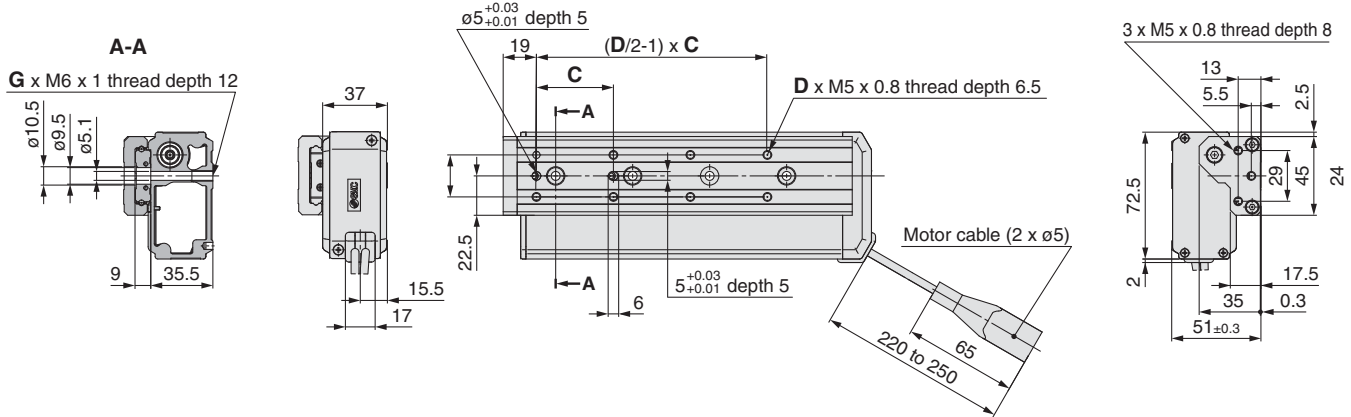
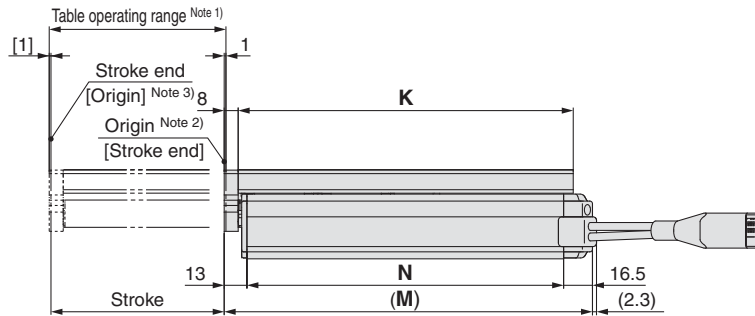
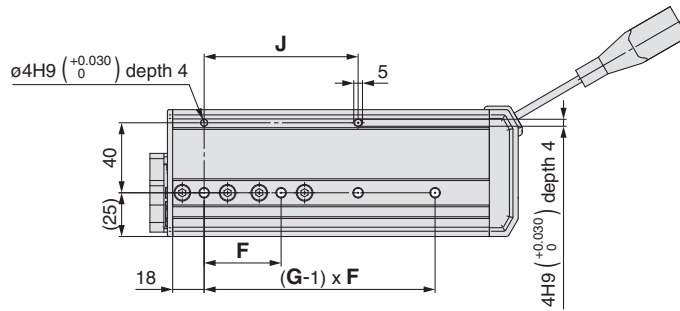

Model	C	D	F	G	J	K	M	N
LESH16L□□-50□□-□□□□□□	40	6	45	2	45	116.5	135.5	106
LESH16L□□-100□□-□□□□□□	44	8	44	4	88	191.5	210.5	181

Note 1) Range within which the table can move when it returns to origin. Make sure a workpiece mounted on the table does not interfere with the work pieces and facilities around the table.
 Note 2) Position after return to origin.
 Note 3) The number in brackets indicates when the direction of return to origin has changed.

Dimensions: Symmetrical Type (L Type)

LESH25L

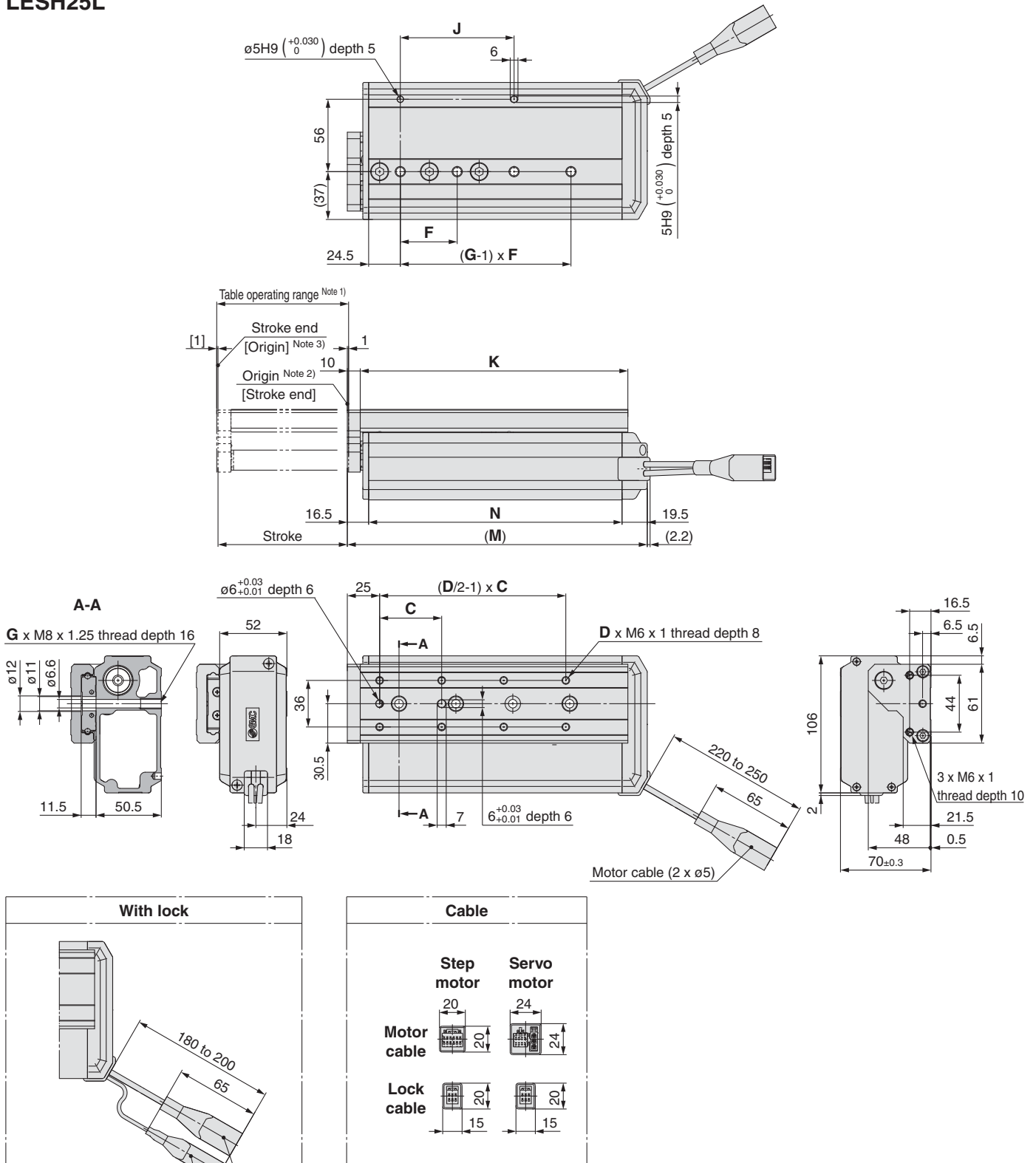

Model	C	D	F	G	J	K	M	N
LESH25L□□-50□□-□□□□□	75	4	80	2	80	143	168	132
LESH25L□□-100□□-□□□□□	48	8	44	4	88	207	232	196
LESH25L□□-150□□-□□□□□	65	8	66	4	132	285	310	274

Note 1) Range within which the table can move when it returns to origin. Make sure a workpiece mounted on the table does not interfere with the work pieces and facilities around the table.
 Note 2) Position after return to origin.
 Note 3) The number in brackets indicates when the direction of return to origin has changed.

Model Selection

Servo Motor (24 VDC)/Step Motor (Servo/24 VDC)

LES

LECA6 / LECP6

LECP1

Specific Product Precautions

Series LES

Dimensions: In-line Motor Type (D Type)

LESH8D

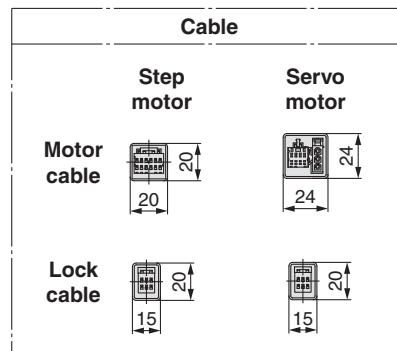
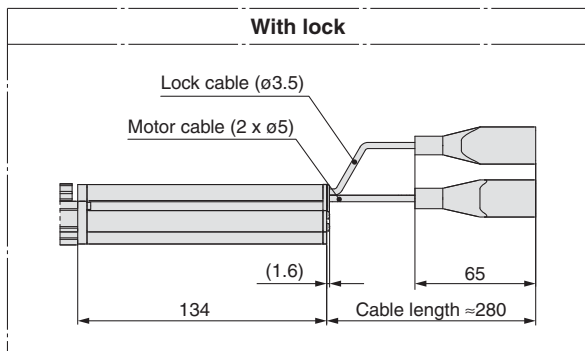
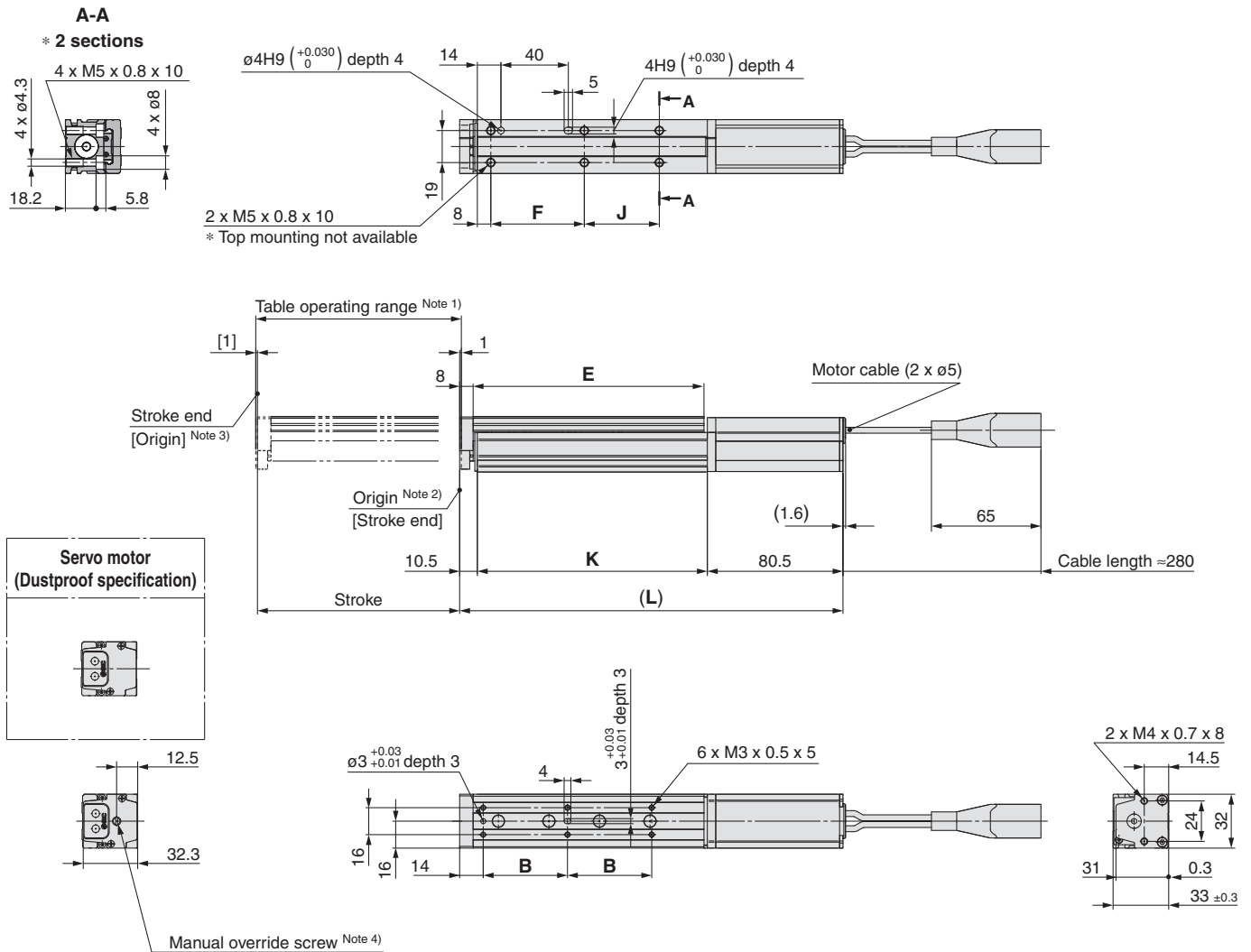

Model	L	B	E	F	J	K
LESH8D□□-50□□-□□□□□□	201.5	46	111	54.5	19.5	110.5
LESH8D□□-50B□□-□□□□□□	255					
LESH8D□□-75□□-□□□□□□	227.5	50	137	55.5	44.5	136.5
LESH8D□□-75B□□-□□□□□□	281					

[mm]

- Note 1) Range within which the table can move when it returns to origin. Make sure a workpiece mounted on the table does not interfere with the work pieces and facilities around the table.
- Note 2) Position after return to origin.
- Note 3) The number in brackets indicates when the direction of return to origin has changed.
- Note 4) The distance between the motor end cover and the manual override screw is max. 16 mm. The motor end cover hole size is $\phi 5.5$.

Dimensions: In-line Motor Type (D Type)

LESH16D

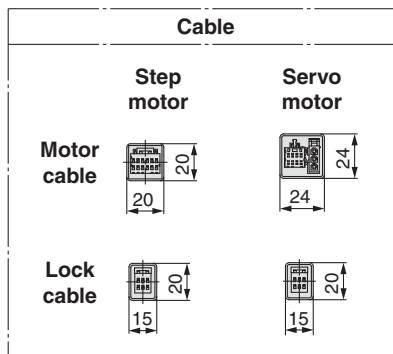
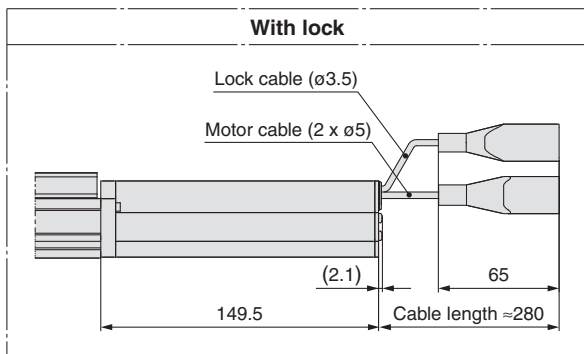
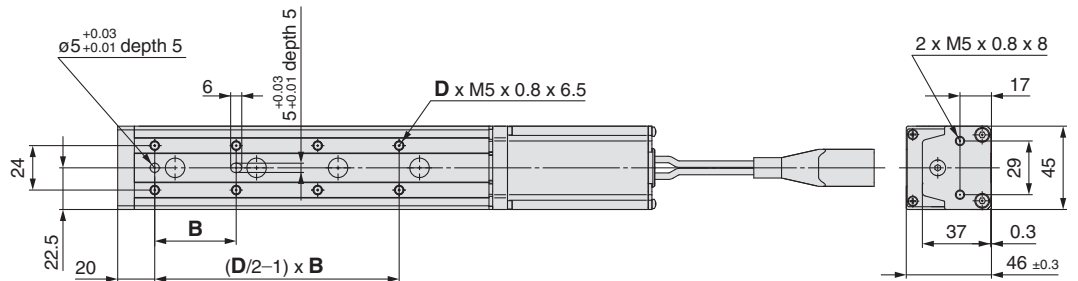
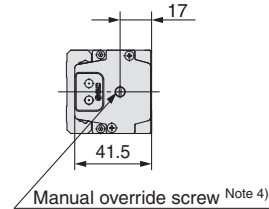
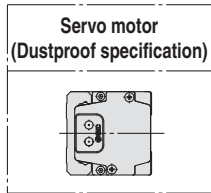
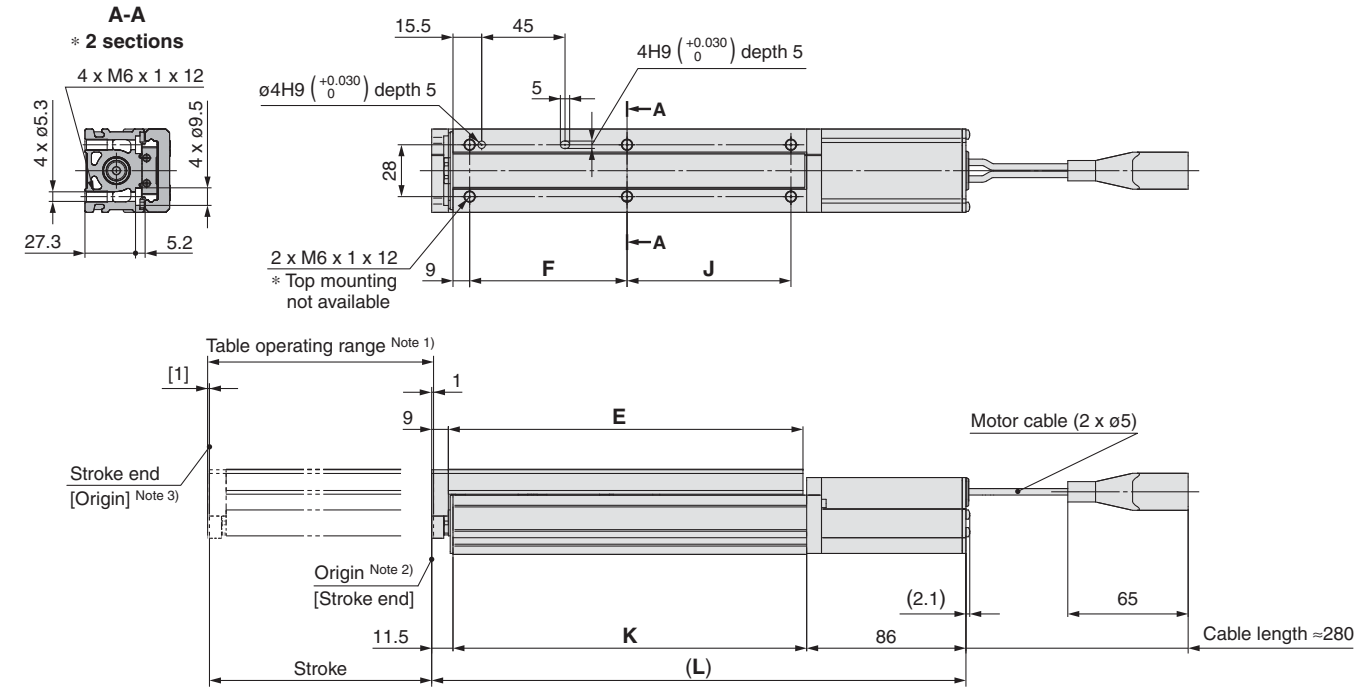

Model	L	B	D	E	F	J	K
LESH16D□□-50□□-□□□□□□	219.5	40	6	116.5	65	39.5	122
LESH16D□□-50B□□-□□□□□□	283						
LESH16D□□-100□□-□□□□□□	288.5	44	8	191.5	85	88.5	191
LESH16D□□-100B□□-□□□□□□	352						

- Note 1) Range within which the table can move when it returns to origin. Make sure a workpiece mounted on the table does not interfere with the work pieces and facilities around the table.
 Note 2) Position after return to origin.
 Note 3) The number in brackets indicates the direction of return to origin has changed.
 Note 4) The distance between the motor end cover and the manual override screw is max. 17mm.
 The motor end cover hole size is ø5.5.

Servo Motor (24 VDC)/Step Motor (Servo/24 VDC)

LECA6 / LECP6

LECP1

Specific Product Precautions

Series LES

Dimensions: In-line Motor Type (D Type)

LESH25D

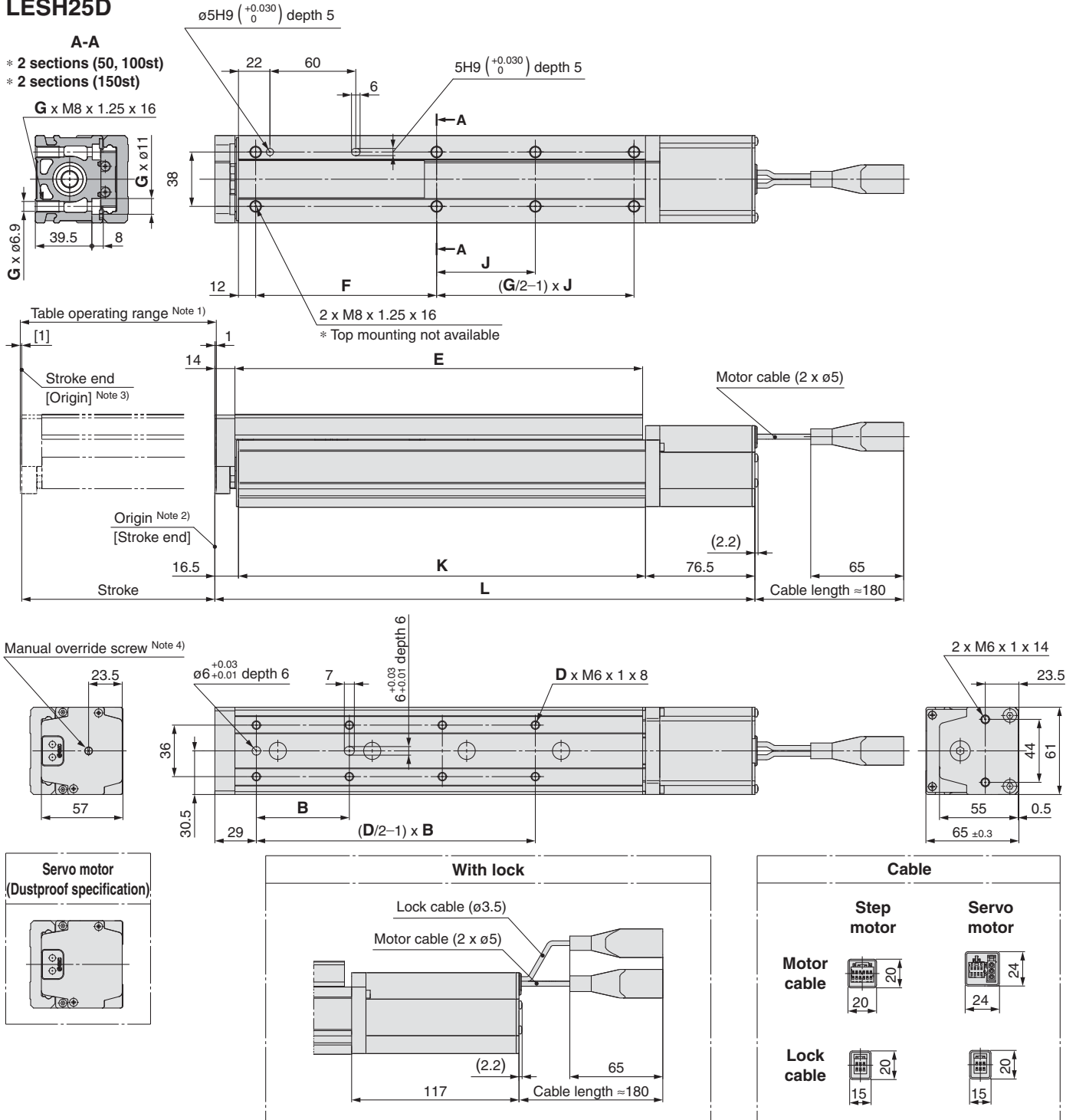

Model	L	B	D	E	F	G	J	K
LESH25D□-50□□-□□□□□□	237.5	75	4	143	84	4	40.5	144.5
LESH25D□-50B□□-□□□□□□	278							
LESH25D□-100□□-□□□□□□	299.5	48	8	207	98.5	6	88	206.5
LESH25D□-100B□□-□□□□□□	340							
LESH25D□-150□□-□□□□□□	377.5	65		285	126.5	6	69	284.5
LESH25D□-150B□□-□□□□□□	418							

Note 1) Range within which the table can move when it returns to origin. Make sure a workpiece mounted on the table does not interfere with the work pieces and facilities around the table.
 Note 2) Position after return to origin.
 Note 3) The number in brackets indicates when the direction of return to origin has changed.
 Note 4) The distance between the motor end cover and the manual override screw is max. 4 mm.
 The motor end cover hole size is ø5.5.

Side Holder (D Type)

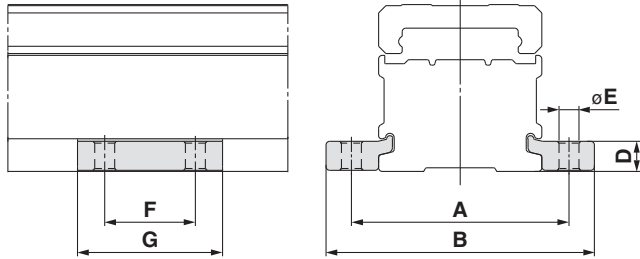

[mm]

Model number <small>(Note)</small>	A	B	D	E	F	G	Applicable model
LE-D-3-1	45	57.6	6.4	4.5	20	33	LESH8D
LE-D-3-2	60	74	8.3	5.5	25	40	LESH16D
LE-D-3-3	81	99	12	6.6	30	49	LESH25D

Note) Model numbers for 1 side holder.

Recommended values for side holder mounting

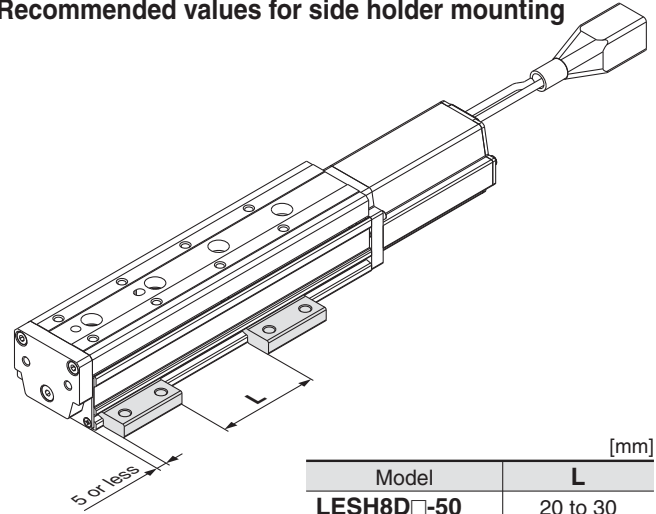

[mm]

Model	L
LESH8D□-50	20 to 30
LESH8D□-75	50 to 60
LESH16D□-50	20 to 30
LESH16D□-100	100 to 125
LESH25D□-50	25 to 35
LESH25D□-100	70 to 100
LESH25D□-150	160 to 180

Model Selection

Servo Motor (24 VDC)/Step Motor (Servo/24 VDC)

LES

LECA6 / LECP6

LECP1

Specific Product Precautions



Series LES Electric Slide Table/ Specific Product Precautions 1

Be sure to read before handling. Refer to back cover for Safety Instructions and the Operation Manual for Electric Actuator Precautions.
Please download it via our website. <http://www.smcworld.com>

Design

⚠ Caution

- Do not apply a load in excess of the operating limit.**
A product should be selected based on the maximum load and allowable moment. If the product is used outside of the operating limit, eccentric load applied to the guide will become excessive and have adverse effects such as creating play at the guide, degraded accuracy and shortened product life.
- Do not use the product in applications where excessive external force or impact force is applied to it.**
This can cause failure.

Handling

⚠ Caution

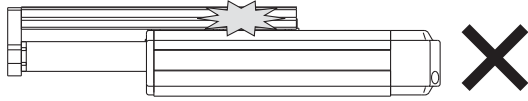
- INP output signal**
 - Positioning operation
When the product comes within the set range by step data [In position], output signal will be turned on.
Initial value: Set to [0.50] or higher.
 - Pushing operation
When the effective force exceeds the [Trigger LV] value, the INP output signal will be turned on. Set the [Pushing force] and [Trigger LV] within the limitation range.
To ensure that the actuator pushes the workpiece with the set [Pushing force], it is recommended that the [Pushing force] and [Trigger LV] are set to the same value.
- When pushing control is used, be sure to set to [Pushing operation]. Never hit at the stroke end other than returning to the original position.**
It may damage or malfunction. The internal stopper can be broken by collision with the stroke end.

- Do not use the following values for the positioning force.**
 - Step motor (Servo 24 VDC): 100%
 - Servo motor (24 VDC): 250%

If the positioning force is set below the above-mentioned values, the cycle time will vary, which may cause an alarm.
- Actual speed of the product can be changed by load.**
When selecting a product, check the catalog for the instructions regarding selection and specifications.
- Do not apply a load, impact or resistance in addition to a transferred load during returning to the original position.**
Otherwise, the original position can be displaced since it is based on detected motor torque.

Handling

⚠ Caution

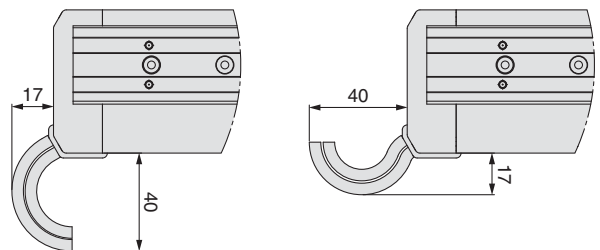
- The table and guide block are made of special stainless steel. There can be rust on the product in an environment exposed to water drops.**
- Do not dent, scratch or cause other damage to the body, table and end plate mounting surfaces.**
It may cause a loss of parallelism in the mounting surfaces, looseness in the guide unit, an increase in sliding resistance or other problems.
- Do not dent, scratch or cause other damage to the surface over which the rail and guide will move.**
Increased sliding resistance and play can result.
- When attaching a workpiece, do not apply strong impact or large moment.**
If an external force over the allowable moment is applied, it may cause looseness in the guide unit, an increase in sliding resistance or other problems.
- Keep the flatness of mounting surface 0.02 mm or less.**
Insufficient flatness of a workpiece or base mounted on the body of the product can cause play at the guide and increased sliding resistance.
- Do not drive the main body with the table fixed.**
- When mounting the product, for R/L type fixed cable, keep more than the bending dimension as shown below. For D type, keep the 40 mm or more for bending the cable.**





Series LES

Electric Slide Table/ Specific Product Precautions 2

Be sure to read before handling. Refer to back cover for Safety Instructions and the Operation Manual for Electric Actuator Precautions.
Please download it via our website. <http://www.smcworld.com>

Handling

⚠ Caution

13. When mounting the product, use screws with adequate length and tighten them to the maximum torque or less.

Tightening with higher torque than the specified range may cause malfunction while the tightening with lower torque can cause the displacement of gripping position or dropping a workpiece.

Body fixed/Side mounting (Body tapped)



Model	Bolt	Max. tightening torque [N·m]	L (Max. screw-in depth mm)
LESH8R/L	M4 x 0.7	1.5	8
LESH8D	M5 x 0.8	3	10
LESH16□	M6 x 1	5.2	12
LESH25□	M8 x 1.25	10	16

Body fixed/Side mounting (Through-hole)

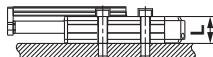

Model	Bolt	Max. tightening torque [N·m]	L [mm]
LESH8R/L	M3 x 0.5	0.63	25.5
LESH8D	M4 x 0.7	1.5	18.2
LESH16R/L	M5 x 0.8	3	35.5
LESH16D			27.3
LESH25R/L	M6 x 1	5.2	50.5
LESH25D			39.5

Workpiece fixed/Front mounting

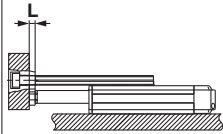

Model	Bolt	Max. tightening torque [N·m]	L [mm]
LESH8R/L	M3 x 0.5	0.63	5.5
LESH8D	M4 x 0.7	1.5	8
LESH16R/L	M5 x 0.8	3	8
LESH16D			9
LESH25R/L	M6 x 1	5.2	10
LESH25D			14

To prevent the workpiece fixing bolts from penetrating the end plate, use bolts that are 0.5 mm or shorter than the maximum screw-in depth. If long bolts are used, they can touch the end plate and cause malfunction, etc.

Workpiece fixed/Top mounting

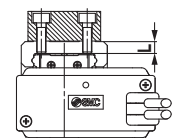

Model	Bolt	Max. tightening torque [N·m]	L (Max. screw-in depth mm)
LESH8□	M3 x 0.5	0.63	5
LESH16□	M5 x 0.8	3	6.5
LESH25□	M6 x 1.0	5.2	8

To prevent the workpiece fixing bolts from touching the guide block, use bolts that are 0.5 mm or shorter than the maximum screw-in depth. If long bolts are used, they can touch the guide block and cause malfunction, etc.

Body fixed/Side mounting (Side holder)

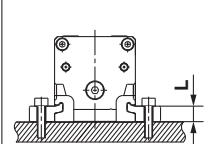

Model	Bolt	Max. tightening torque [N·m]	L [mm]
LESH8D	M4 x 0.7	1.5	6.7
LESH16D	M5 x 0.8	3	8.3
LESH25D	M6 x 1	5.2	12

When using the side holder to install the actuator, be sure to use the dowel positioning pin. It can be displaced when vibration or excessive external force is applied.

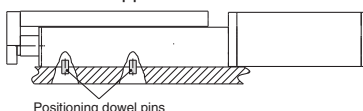

14. In pushing operation, set the product to a position of at least 0.5 mm away from a workpiece.

If the product is set to the same position as a workpiece, the following alarm and unstable operation can occur.

a. "Posn failed" alarm is generated.

The product cannot reach a pushing start position due to the deviation of work pieces in width.

b. "Pushing ALM" alarm is generated.

The product is pushed back from a pushing start position after starting to push.

15. Actuator sizing is necessary with reducing work load if external force is applied on the actuator table.

When mounting cable-duct to actuator, the resistance of actuator table may increase. It causes an overload alarm, so pay attention to the resistance.

16. When using the side holder to install the actuator, use within the dimension range below.

Installation balance will deteriorate and cause loosening.

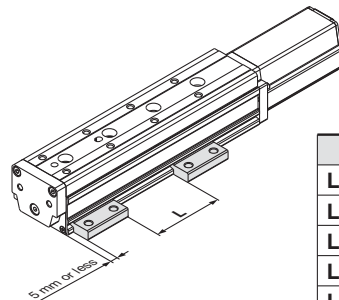

Model	L [mm]
LESH8D□-50	20 to 30
LESH8D□-75	50 to 60
LESH16D□-50	20 to 30
LESH16D□-100	100 to 125
LESH25D□-50	25 to 35
LESH25D□-100	70 to 100
LESH25D□-150	160 to 180

17. Do not grasp or peel off masking tape on the back side of the LESH□D body.

The masking tape may peel off and foreign matter may get inside the actuator.

18. When the table moves, a gap will form between the motor flange and LESH□D (maked with arrow below). Be careful not to put hands or fingers in a gap.





Series LES Electric Slide Table/ Specific Product Precautions 3

Be sure to read before handling. Refer to back cover for Safety Instructions and the Operation Manual for Electric Actuator Precautions.
Please download it via our website. <http://www.smcworld.com>

Handling

Caution

19. When mounting the body with through holes in the mounting orientations below, please make sure to use two side holders as shown in the figures.

Installation balance will deteriorate and cause loosening.

Ceiling mounting

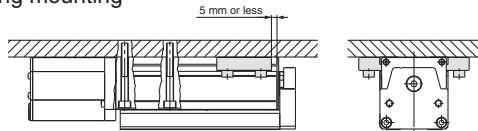

Wall mounting

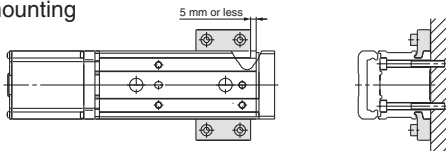

Vertical mounting

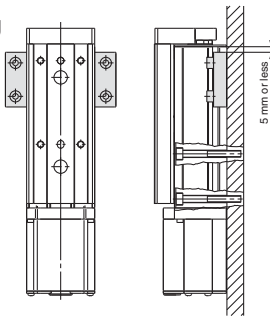

20. Install the body as shown below with the ○.

Since the product support becomes unstable, it may cause operation malfunction, irregular noise and deflection.

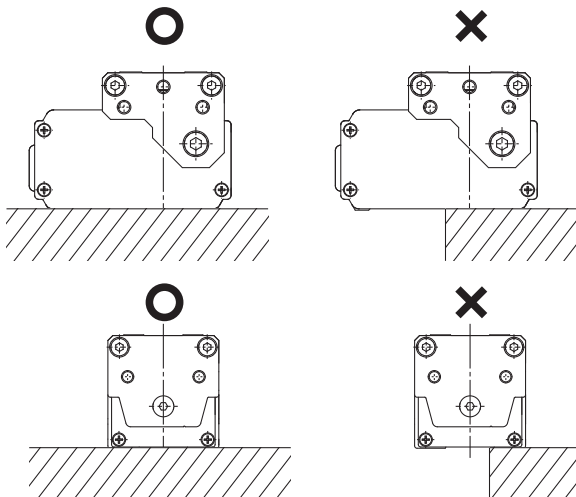

21. Even with the same product number, the table of some products can be moved by hand and the table of some products cannot be moved by hand. However, there is no abnormality with these products. (Without lock)

This difference is caused because there is a little variation with the positive efficiency (when the table is moved by the motor) and there is a large variation with the reverse-efficiency (when the table is moved manually) due to the product characteristics. There is hardly any difference among products when they are operated by the motor.

Maintenance

Warning

Maintenance frequency

Perform maintenance according to the table below.

Frequency	Appearance check	Check belt
Inspection before daily operation	○	—
Inspection every 6 months*	—	○
Inspection every 250 km*	—	○
Inspection are every 5 million cycles*	—	○

* Select whichever comes sooner.

Items for visual appearance check

1. Loose set screws, Abnormal dirt
2. Check of flaw and cable joint
3. Vibration, Noise

Items for belt check (R/L type only)

Stop operation immediately and replace the belt when belt appear to be below.

a. **Tooth shape canvas is worn out.**

Canvas fiber becomes fuzzy. Rubber is removed and the fiber becomes whitish. Lines of fibers become unclear.

b. **Peeling off or wearing of the side of the belt**

Belt corner becomes round and frayed thread sticks out.

c. **Belt partially cut**

Belt is partially cut. Foreign matter caught in teeth other than cut part causes flaw.

d. **Vertical line of belt teeth**

Flaw which is made when the belt runs on the flange.

e. **Rubber back of the belt is softened and sticky.**

f. **Crack on the back of the belt**

It is recommended that the belt be replaced after 2 years or after following actuator movement distance.

The life of the belt may be reduced due to operating conditions and the environment.

Check the belt regularly as shown in "Maintenance frequency" and replace belt if any abnormality is detected.

LESH8□□K: 1500 km

LESH8□□J: Maintenance free

LESH16□□K: 1500 km

LESH16□□J: Maintenance free

LESH25□□K: Maintenance free

LESH25□□J: Maintenance free

Controller

Step Data Input Type Page 29



Step Motor
(Servo/24 VDC)

Series LECP6



Servo Motor
(24 VDC)

Series LECA6

Servo Motor (24 VDC)/Step Motor (Servo/24 VDC)

LES

LECA6 / LECP6

LECP1

Programless Type Page 41



Step Motor
(Servo/24 VDC)

Series LECP1

Controller (Step Data Input Type) Step Motor (Servo/24 VDC)

Series **LECP6**

Servo Motor (24 VDC)

Series **LECA6**



Series **LECP6** Series **LECA6**

How to Order

⚠ Caution

Note 1) CE-compliant products

① EMC compliance was tested by combining the electric actuator LES series and the controller LEC series. The EMC depends on the configuration of the customer's control panel and the relationship with other electrical equipment and wiring. Therefore conformity to the EMC directive cannot be certified for SMC components incorporated into the customer's equipment under actual operating conditions. As a result it is necessary for the customer to verify conformity to the EMC directive for the machinery and equipment as a whole.

② For the LECA6 series (servo motor controller), EMC compliance was tested by installing a noise filter set (LEC-NFA). Refer to page 37 for the noise filter set. Refer to the LECA Operation Manual for installation.

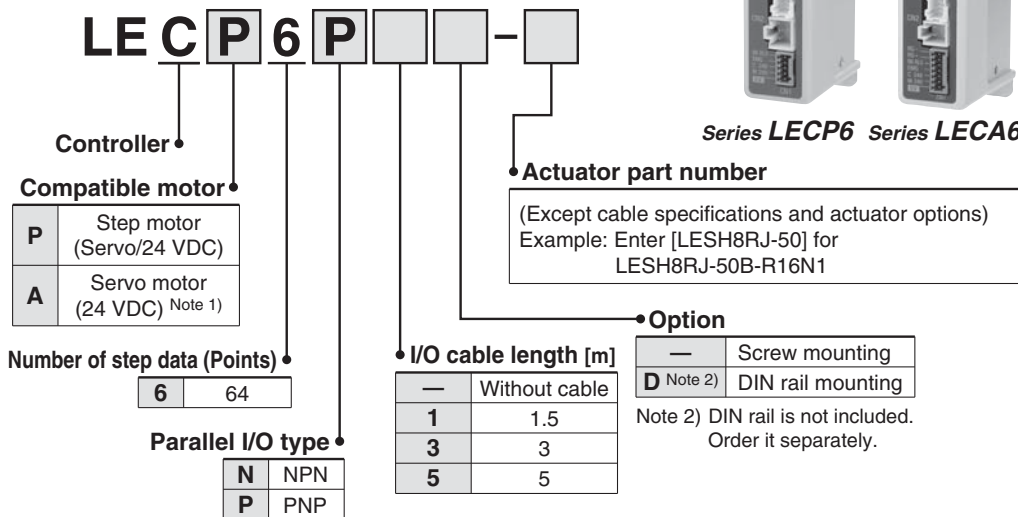

* When controller equipped type (-□6N□/-□6P□) is selected when ordering the LE series, you do not need to order this controller.

The controller is sold as single unit after the compatible actuator is set.

Confirm that the combination of the controller and the actuator is correct.

<Check the following before use.>

- ① Check that the actuator label for model number. Matches the controller label.
- ② Check that the Parallel I/O configuration matches (NPN or PNP).

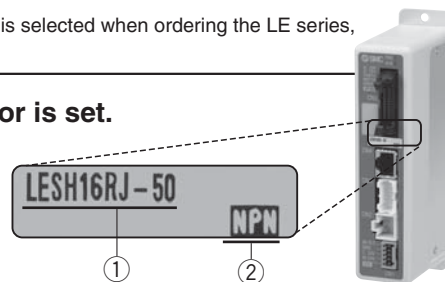

* Refer to the operation manual for using the products. Please download it via our website. <http://www.smcworld.com>

Specifications

Basic Specifications

Item	LECP6	LECA6
Compatible motor	Step motor (Servo/24 VDC)	Servo motor (24 VDC)
Power supply <small>Note 1)</small>	Power voltage: 24 VDC ±10% Current consumption: 3 A (Peak 5 A) <small>Note 2)</small> [Including motor drive power, control power, stop, lock release]	Power voltage: 24 VDC ±10% Current consumption: 3 A (Peak 10 A) <small>Note 2)</small> [Including motor drive power, control power, stop, lock release]
Parallel input	11 inputs (Photo-coupler isolation)	
Parallel output	13 outputs (Photo-coupler isolation)	
Compatible encoder	Incremental A/B phase (800 pulse/rotation)	Incremental A/B/Z phase (800 pulse/rotation)
Serial communication	RS485 (Modbus protocol compliant)	
Memory	EEPROM	
LED indicator	LED (Green/Red) one of each	
Lock control	Forced-lock release terminal <small>Note 3)</small>	
Cable length [m]	I/O cable: 5 or less Actuator cable: 20 or less	
Cooling system	Natural air cooling	
Operating temperature range [°C]	0 to 40 (No freezing)	
Operating humidity range [%RH]	90 or less (No condensation)	
Storage temperature range [°C]	-10 to 60 (No freezing)	
Storage humidity range [%RH]	90 or less (No condensation)	
Insulation resistance [MΩ]	Between the housing (radiation fin) and SG terminal 50 (500 VDC)	
Weight [g]	150 (Screw mounting) 170 (DIN rail mounting)	

Note 1) Do not use the power supply of "inrush current prevention type" for the controller power supply.

Note 2) The power consumption changes depending on the actuator model. Refer to the specifications of actuator for more details.

Note 3) Applicable to non-magnetizing lock.

How to Mount

a) Screw mounting (LEC□6□□-□) (Installation with two M4 screws)

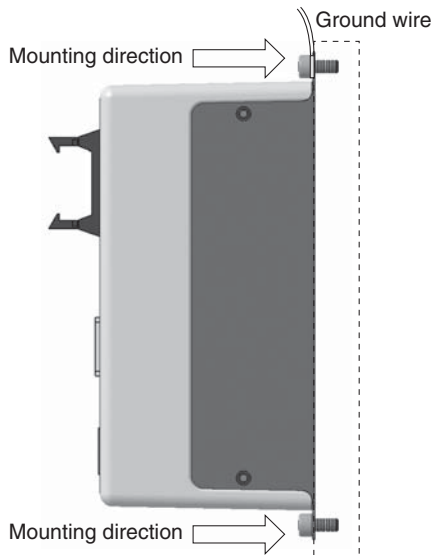

b) DIN rail mounting (LEC□6□□D-□) (Installation with the DIN rail)

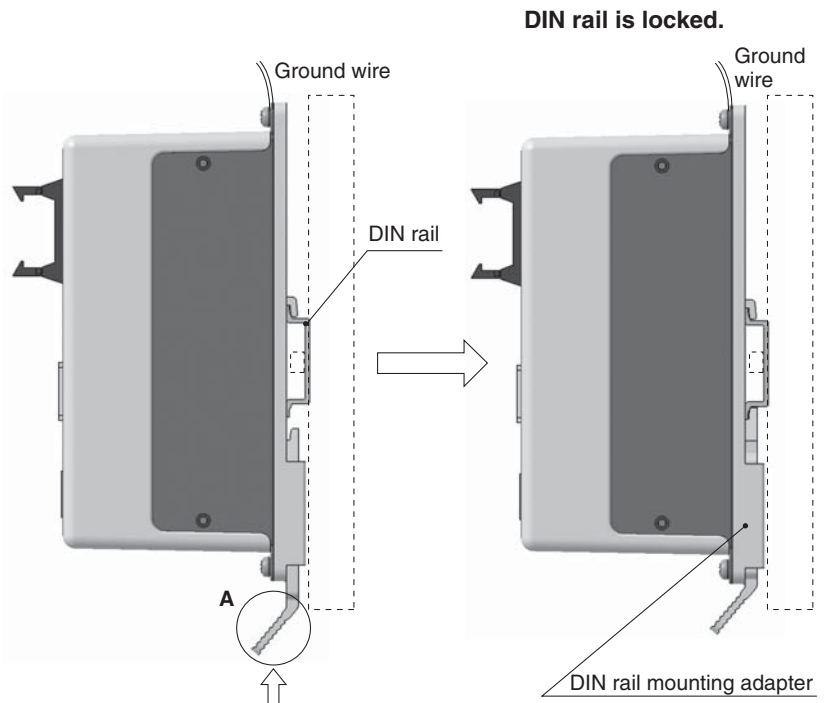

Hook the controller on the DIN rail and press the lever of section A in the arrow direction to lock it.

DIN rail AXT100-DR-□

* For □, enter a number from the "No." line in the table below.
Refer to the dimensions on page 31 for the mounting dimensions.

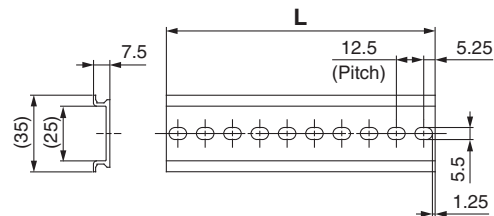

L Dimension [mm]

No.	1	2	3	4	5	6	7	8	9	10	11	12	13	14	15	16	17	18	19	20
L	23	35.5	48	60.5	73	85.5	98	110.5	123	135.5	148	160.5	173	185.5	198	210.5	223	235.5	248	260.5
No.	21	22	23	24	25	26	27	28	29	30	31	32	33	34	35	36	37	38	39	40
L	273	285.5	298	310.5	323	335.5	348	360.5	373	385.5	398	410.5	423	435.5	448	460.5	473	485.5	498	510.5

DIN rail mounting adapter LEC-D0 (with 2 mounting screws)

This should be used when the DIN rail mounting adapter is mounted onto the screw mounting type controller afterwards.

Series LECP6

Series LECA6

Dimensions

a) Screw mounting (LEC□6□□-□)

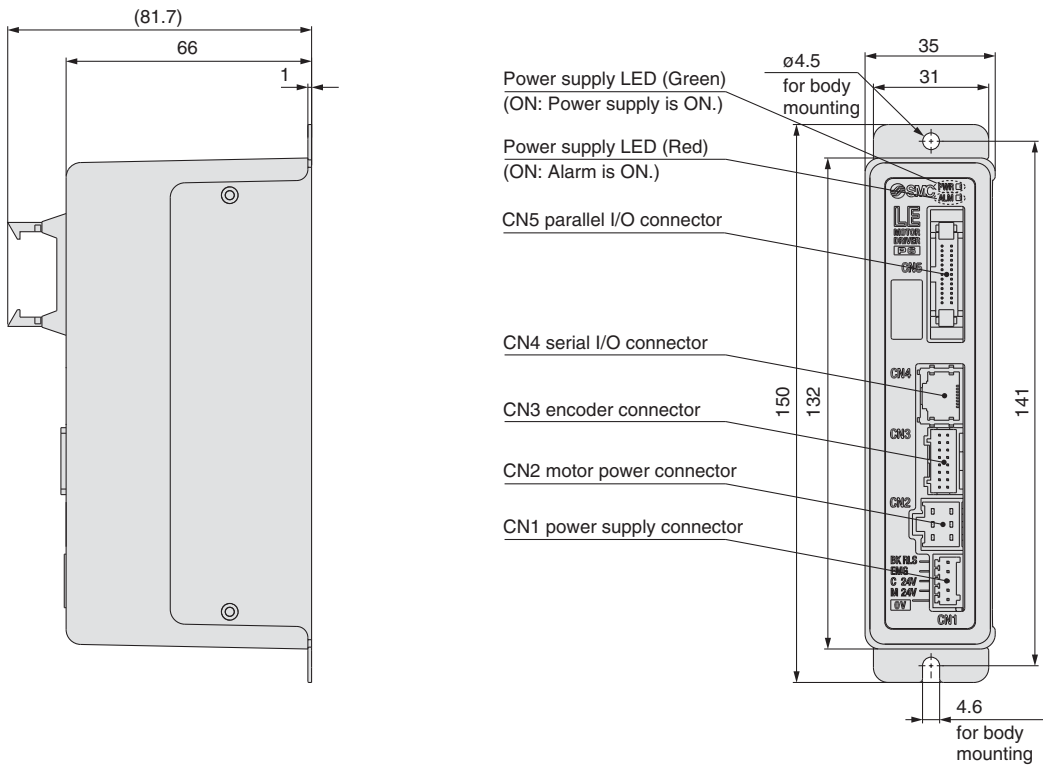

b) DIN rail mounting (LEC□6□□D-□)

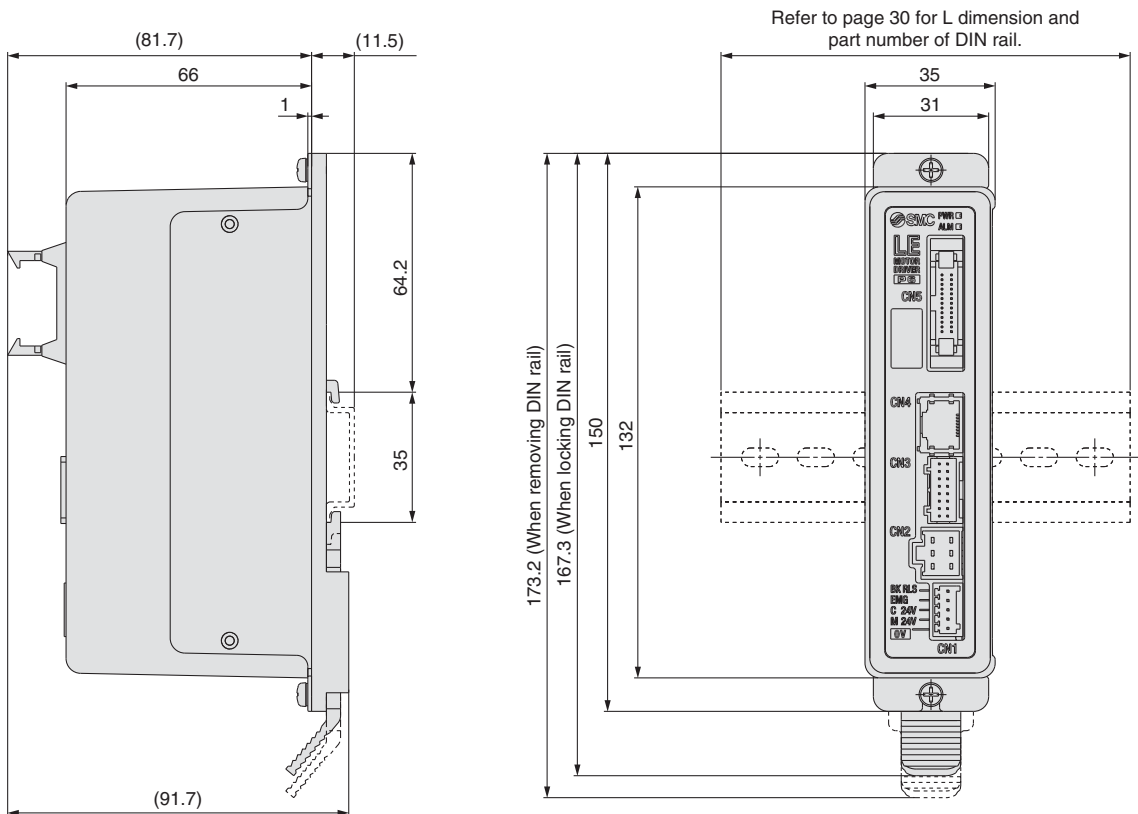

Wiring Example 1

Power Supply Connector: CN1 * Power supply plug is an accessory.

CN1 Power Supply Connector Terminal for LECP6 (PHOENIX CONTACT FK-MC0.5/5-ST-2.5)

Terminal name	Function	Function details
0V	Common supply (-)	M24V terminal/C24V terminal/EMG terminal/BK RLS terminal are common (-).
M24V	Motor power supply (+)	This is the motor power supply (+) that is supplied to the controller.
C24V	Control power supply (+)	This is the control power supply (+) that is supplied to the controller.
EMG	Stop (+)	This is the input (+) that releases the stop.
BK RLS	Lock release (+)	This is the input (+) that releases the lock.

CN1 Power Supply Connector Terminal for LECA6 (PHOENIX CONTACT FK-MC0.5/7-ST-2.5)

Terminal name	Function	Function details
0V	Common supply (-)	M24V terminal/C24V terminal/EMG terminal/BK RLS terminal are common (-).
M24V	Motor power supply (+)	This is the motor power supply (+) that is supplied to the controller.
C24V	Control power supply (+)	This is the control power supply (+) that is supplied to the controller.
EMG	Stop (+)	This is the input (+) that releases the stop.
BK RLS	Lock release (+)	This is the input (+) that releases the lock.
RG+	Regenerative output 1	These are the regenerative output terminals for external connection. (It is not necessary to connect them in the combination with standard specification LE series.)
RG-	Regenerative output 2	

Power supply plug for LECP6

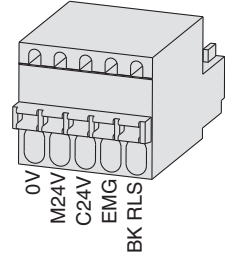

Power supply plug for LECA6

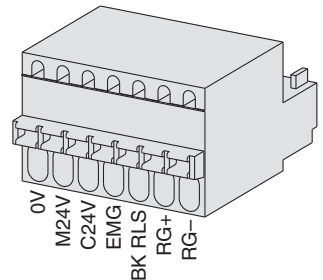

Wiring Example 2

Parallel I/O Connector: CN5 * When you connect a PLC, etc., to the CN5 parallel I/O connector, please use the I/O cable (LEC-CN5-□).
* The wiring should be changed depending on the type of the parallel I/O (NPN or PNP). Please wire referring to the following diagram.

Wiring diagram

LEC□6N□□□□ (NPN)

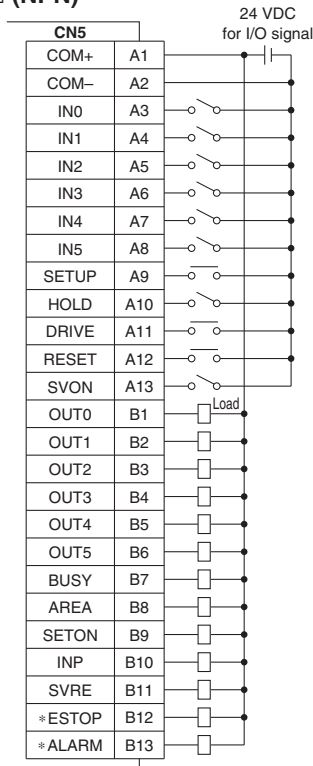

LEC□6P□□□□ (PNP)

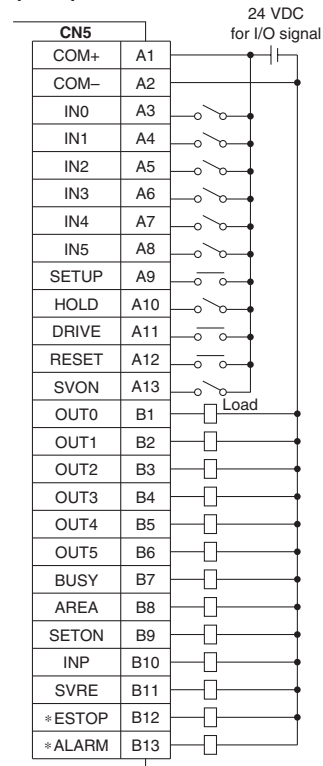

Input Signal

Name	Contents
COM +	Connects the power supply 24 V for input/output signal
COM -	Connects the power supply 0 V for input/output signal
IN0 to IN5	Step data specified Bit No. (Input is instructed in the combination of IN0 to 5.)
SETUP	Instruction to return to the original position
HOLD	Operation is temporarily stopped
DRIVE	Instruction to drive
RESET	Alarm reset and operation interruption
SVON	Servo ON instruction

Output Signal

Name	Contents
OUT0 to OUT5	Outputs the step data No. during operation
BUSY	Outputs when the actuator is moving
AREA	Outputs within the step data area output setting range
SETON	Outputs when returning to the original position
INP	Outputs when target position or target force is reached (Turns on when the positioning or pushing is completed.)
SVRE	Outputs when servo is on
* ESTOP (Note)	Not output when EMG stop is instructed
* ALARM (Note)	Not output when alarm is generated

Note) These signals are output when the power supply of the controller is ON. (N.C.)

Series LECP6

Series LECA6

Step Data Setting

1. Step data setting for positioning

In this setting, the actuator moves toward and stops at the target position. The following diagram shows the setting items and operation. The setting items and set values for this operation are stated below.

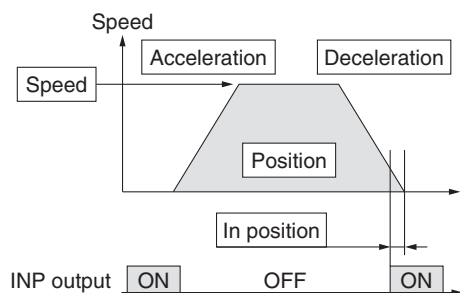

◎: Need to be set.
○: Need to be adjusted as required.
—: Setting is not required.

Step Data (Positioning)

Necessity	Item	Description
◎	Movement MOD	When the absolute position is required, set Absolute. When the relative position is required, set Relative.
◎	Speed	Transfer speed to the target position
◎	Position	Target position
○	Acceleration	Parameter which defines how rapidly the actuator reaches the speed set. The higher the set value, the faster it reaches the speed set.
○	Deceleration	Parameter which defines how rapidly the actuator comes to stop. The higher the set value, the quicker it stops.
◎	Pushing force	Set 0. (If values 1 to 100 are set, the operation will be changed to the pushing operation.)
—	Trigger LV	Setting is not required.
—	Pushing speed	Setting is not required.
○	Positioning force	Max. torque during the positioning operation (No specific change is required.)
○	Area 1, Area 2	Condition that turns on the AREA output signal.
○	In position	Condition that turns on the INP output signal. When the actuator enters the range of [in position], the INP output signal turns on. (It is unnecessary to change this from the initial value.) When it is necessary to output the arrival signal before the operation is completed, make the value larger.

2. Step data setting for pushing

The actuator moves toward the pushing start position, and when it reaches that position, it starts pushing with less than the set force. The following diagram shows the setting items and operation. The setting items and set values for this operation are stated below.

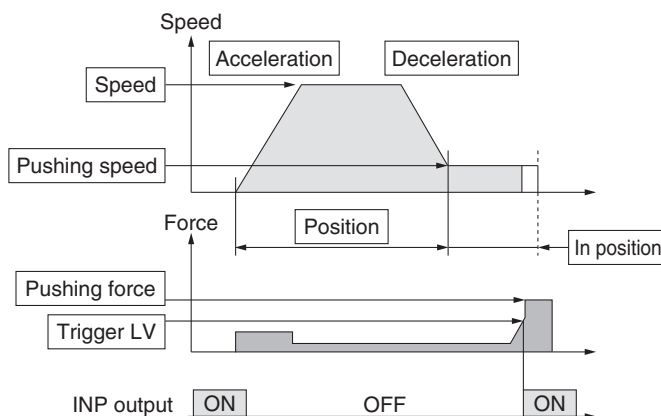

◎: Need to be set.
○: Need to be adjusted as required.

Step Data (Pushing)

Necessity	Item	Description
◎	Movement MOD	When the absolute position is required, set Absolute. When the relative position is required, set Relative.
◎	Speed	Transfer speed to the pushing start position
◎	Position	Pushing start position
○	Acceleration	Parameter which defines how rapidly the actuator reaches the speed set. The higher the set value, the faster it reaches the speed set.
○	Deceleration	Parameter which defines how rapidly the actuator comes to stop. The higher the set value, the quicker it stops.
◎	Pushing force	Pushing force ratio is defined. The setting range differs depending on the electric actuator type. Refer to the operation manual for the electric actuator.
◎	Trigger LV	Condition that turns on the INP output signal. The INP output signal is turned on when the generated force exceeds the value. Threshold level should be less than the pushing force.
○	Pushing speed	Pushing speed When the speed is set fast, the electric actuator and work pieces might be damaged due to the impact when they hit the end, so this set value should be smaller. Refer to the operation manual of the electric actuator.
○	Positioning force	Max. torque during the positioning operation (No specific change is required.)
○	Area 1, Area 2	Condition that turns on the AREA output signal.
◎	In position	Transfer distance during pushing. If the transferred distance exceeds the setting, it stops even if it is not pushing. If the transfer distance is exceeded, the INP output signal will not be turned on.

Signal Timing

Return to Origin

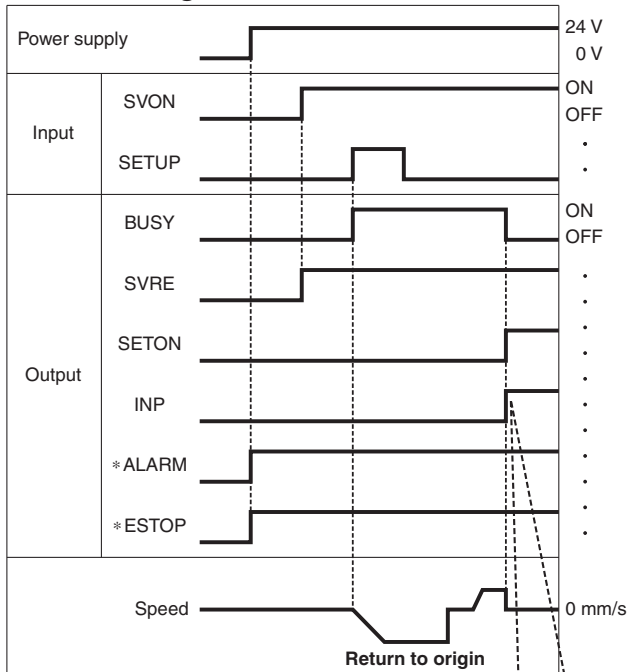

If the actuator is within the "in position" range of the basic parameter, INP will be turned ON, but if not, it will remain OFF.

* *ALARM" and *ESTOP" are expressed as negative-logic circuit.

Positioning Operation

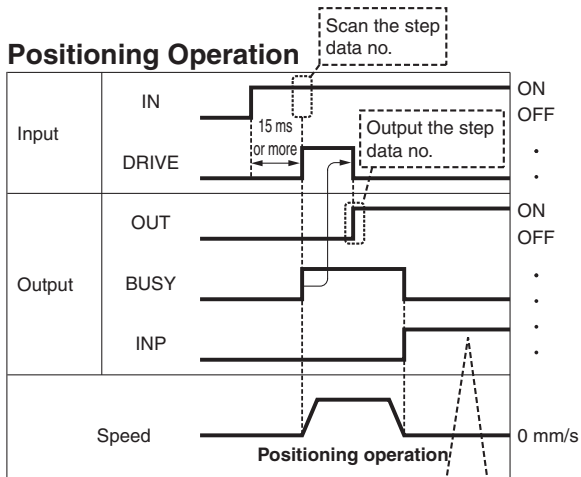

If the actuator is within the "in position" range of the step data, INP will be turned ON, but if not, it will remain OFF.

* "OUT" is output when "DRIVE" is changed from ON to OFF. (When power supply is applied, "DRIVE" or "RESET" is turned ON or *ESTOP" is turned OFF, all of the "OUT" outputs are turned OFF.)

HOLD

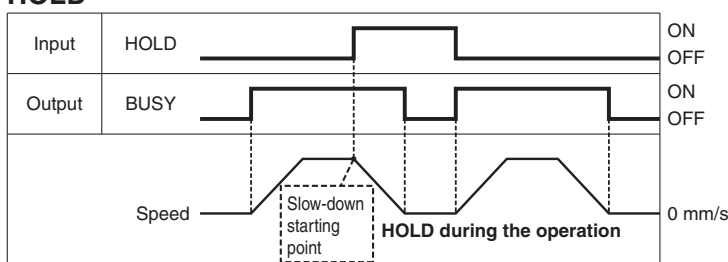

* When the actuator is in the positioning range in the pushing operation, it does not stop even if HOLD signal is input.

Pushing Operation

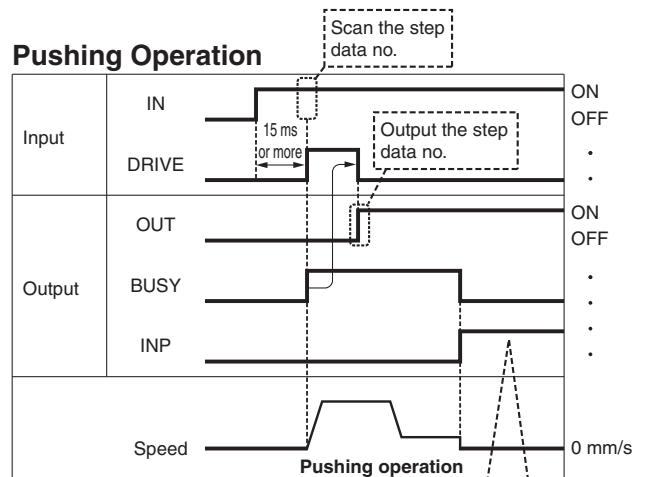

If the current pushing force exceeds the "threshold level" of the step data, INP signal will be turned ON.

Reset

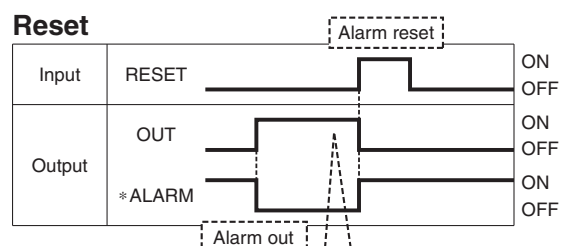

It is possible to identify the alarm group by the combination of OUT signals when the alarm is generated.

* *ALARM" is expressed as negative-logic circuit.

Series LECP6

Series LECA6

Options: Actuator Cable

[Robotic cable for step motor (Servo/24 VDC), standard cable]

LE-CP-1-

Cable length (L)[m]

1	1.5
3	3
5	5
8	8*
A	10*
B	15*
C	20*

* Produced upon receipt of order
(Robotic cable only)

Cable type

-	Robotic cable (Flexible cable)
S	Standard cable

LE-CP-¹/₅ / Cable length: 1.5 m, 3 m, 5 m

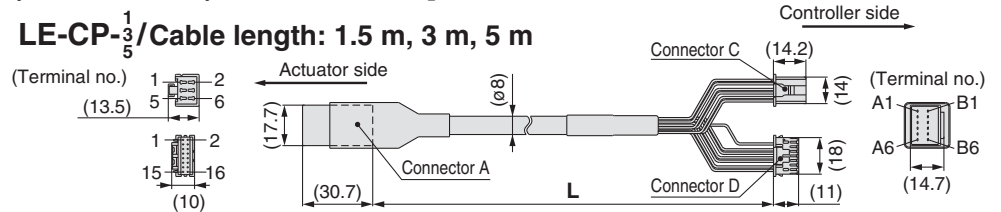

LE-CP-^{8B}/_{AC} / Cable length: 8 m, 10 m, 15 m, 20 m
(* Produced upon receipt of order)

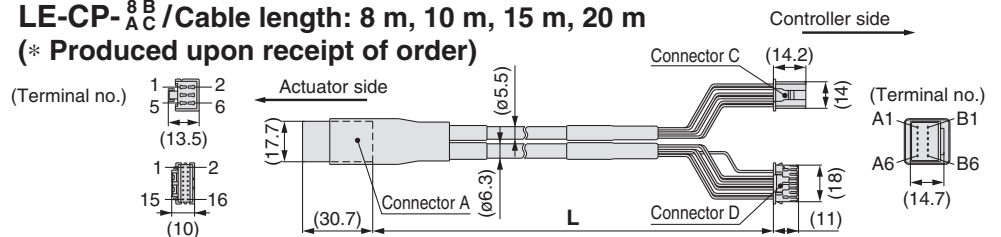

Circuit	Connector A terminal no.	Cable colour	Connector C terminal no.
A	B-1	Brown	2
A	A-1	Red	1
B	B-2	Orange	6
B	A-2	Yellow	5
COM-A/COM	B-3	Green	3
COM-B/-	A-3	Blue	4
Shield			
Circuit	Connector A terminal no.	Cable colour	Connector D terminal no.
Vcc	B-4	Brown	12
GND	A-4	Black	13
A	B-5	Red	7
A	A-5	Black	6
B	B-6	Orange	9
B	A-6	Black	8
			3

[Robotic cable with lock and sensor for step motor (Servo/24 VDC), standard cable]

LE-CP-1-B-

Cable length (L)[m]

1	1.5
3	3
5	5
8	8*
A	10*
B	15*
C	20*

* Produced upon receipt of order
(Robotic cable only)

With lock and sensor

Cable type

-	Robotic cable (Flexible cable)
S	Standard cable

LE-CP-¹/₅ / Cable length: 1.5 m, 3 m, 5 m

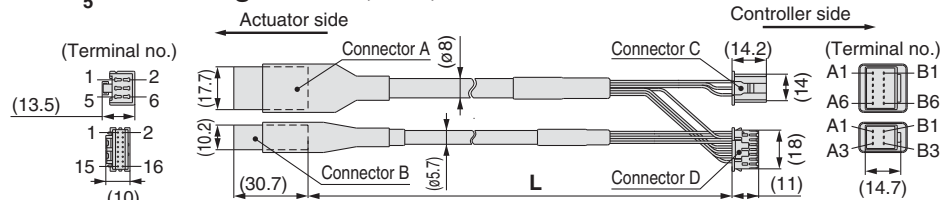

LE-CP-^{8B}/_{AC} / Cable length: 8 m, 10 m, 15 m, 20 m
(* Produced upon receipt of order)

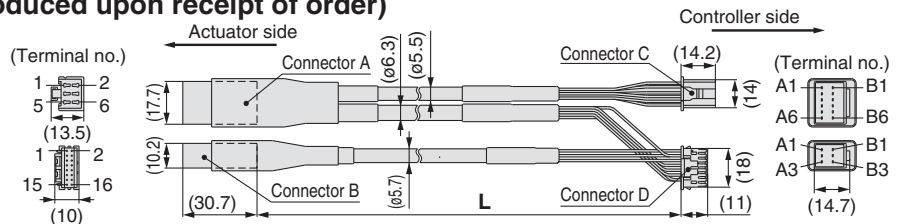

Circuit	Connector A terminal no.	Cable colour	Connector C terminal no.
A	B-1	Brown	2
A	A-1	Red	1
B	B-2	Orange	6
B	A-2	Yellow	5
COM-A/COM	B-3	Green	3
COM-B/-	A-3	Blue	4
Shield			
Circuit	Connector A terminal no.	Cable colour	Connector D terminal no.
Vcc	B-4	Brown	12
GND	A-4	Black	13
A	B-5	Red	7
A	A-5	Black	6
B	B-6	Orange	9
B	A-6	Black	8
			3
Circuit	Connector B terminal no.	Cable colour	Connector C terminal no.
Lock (+)	B-1	Red	4
Lock (-)	A-1	Black	5
Sensor (+) Note	B-3	Brown	1
Sensor (-) Note	A-3	Blue	2

Note) This is not used for the LES series.

[Robotic cable for servo motor (24 VDC)]

LE-CA-1

Cable length (L)[m]

1	1.5
3	3
5	5
8	8*
A	10*
B	15*
C	20*

* Produced upon receipt of order

LE-CA-□

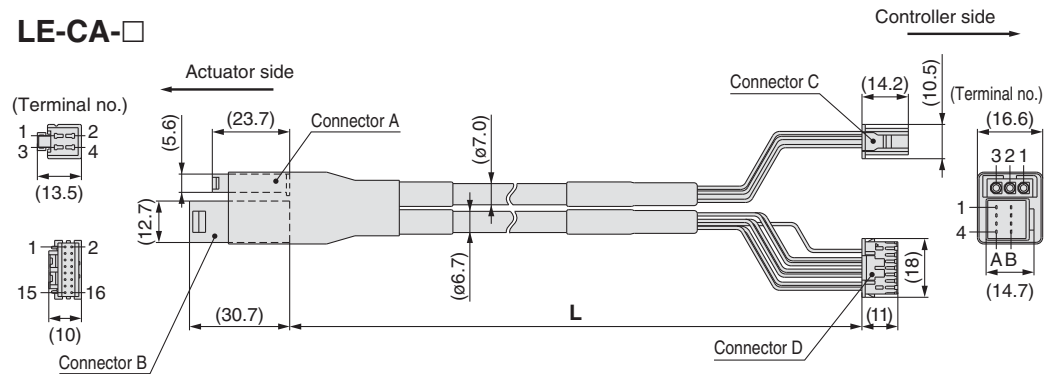

Circuit	Connector A terminal no.	Cable colour	Connector C terminal no.
U	1	Red	1
V	2	White	2
W	3	Black	3

Circuit	Connector B terminal no.	Cable colour	Connector D terminal no.
Vcc	B-1	Brown	12
GND	A-1	Black	13
A	B-2	Red	7
A	A-2	Black	6
B	B-3	Orange	9
B	A-3	Black	8
Z	B-4	Yellow	11
Z	A-4	Black	10
		—	3

Connection of shield material

[Robotic cable with lock and sensor for servo motor (24 VDC)]

LE-CA-1-B

Cable length (L)[m]

1	1.5
3	3
5	5
8	8*
A	10*
B	15*
C	20*

* Produced upon receipt of order

With lock and sensor

LE-CA-□-B

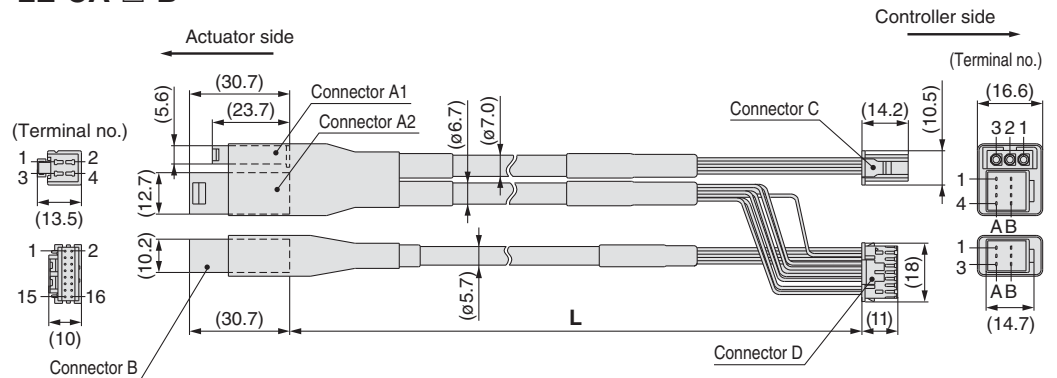

Circuit	Connector A1 terminal no.	Cable colour	Connector C terminal no.
U	1	Red	1
V	2	White	2
W	3	Black	3

Circuit	Connector A2 terminal no.	Cable colour	Connector D terminal no.
Vcc	B-1	Brown	12
GND	A-1	Black	13
A	B-2	Red	7
A	A-2	Black	6
B	B-3	Orange	9
B	A-3	Black	8
Z	B-4	Yellow	11
Z	A-4	Black	10
		—	3

Circuit	Connector B terminal no.	Cable colour	Terminal no.
Lock (+)	B-1	Red	4
Lock (-)	A-1	Black	5
Sensor (+) ^{Note}	B-3	Brown	1
Sensor (-) ^{Note}	A-3	Black	2

Note) This is not used for the LES series.

Servo Motor (24 VDC)/Step Motor (Servo/24 VDC)

LES

LECA6 / LECP6

LECP1

Specific Product Precautions

Series LECP6

Series LECA6

Option: I/O Cable

LEC – CN5 – 1

Cable length (L) [m]	
1	1.5
3	3
5	5

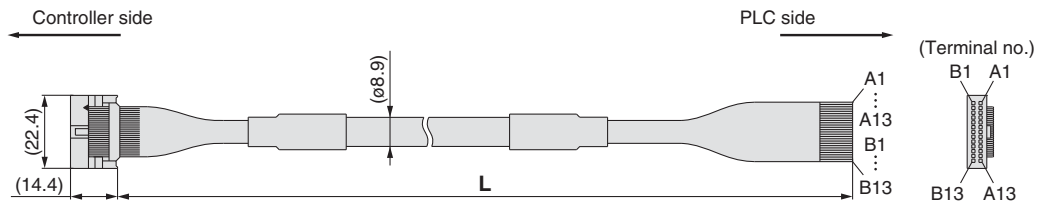

* Conductor size: AWG28

Connector pin No.	Insulation colour	Dot mark	Dot colour
A1	Light brown	■	Black
A2	Light brown	■	Red
A3	Yellow	■	Black
A4	Yellow	■	Red
A5	Light green	■	Black
A6	Light green	■	Red
A7	Grey	■	Black
A8	Grey	■	Red
A9	White	■	Black
A10	White	■	Red
A11	Light brown	■ ■	Black
A12	Light brown	■ ■	Red
A13	Yellow	■ ■	Black

Connector pin No.	Insulation colour	Dot mark	Dot colour
B1	Yellow	■ ■	Red
B2	Light green	■ ■	Black
B3	Light green	■ ■	Red
B4	Grey	■ ■	Black
B5	Grey	■ ■	Red
B6	White	■ ■	Black
B7	White	■ ■	Red
B8	Light brown	■ ■ ■	Black
B9	Light brown	■ ■ ■	Red
B10	Yellow	■ ■ ■	Black
B11	Yellow	■ ■ ■	Red
B12	Light green	■ ■ ■	Black
B13	Light green	■ ■ ■	Red
—	Shield		

Option: Noise Filter Set for Servo Motor (24 VDC)

LEC – NFA

Contents of the set: 2 noise filters (Produced by WURTH ELEKTRONIK: 74271222)

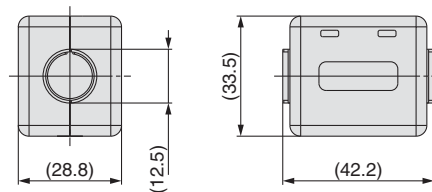

* Refer to the LECA6 series Operation Manual for installation.

Series LEC Controller Setting Kit/LEC-W1

How to Order

LEC-W2

Controller setting kit
(Japanese and English are available.)

Contents

- ① Controller setting software (CD-ROM)
- ② Communication cable
(Cable between the controller and the conversion unit)
- ③ Conversion unit
- ④ USB cable
(Cable between the PC and the conversion unit)

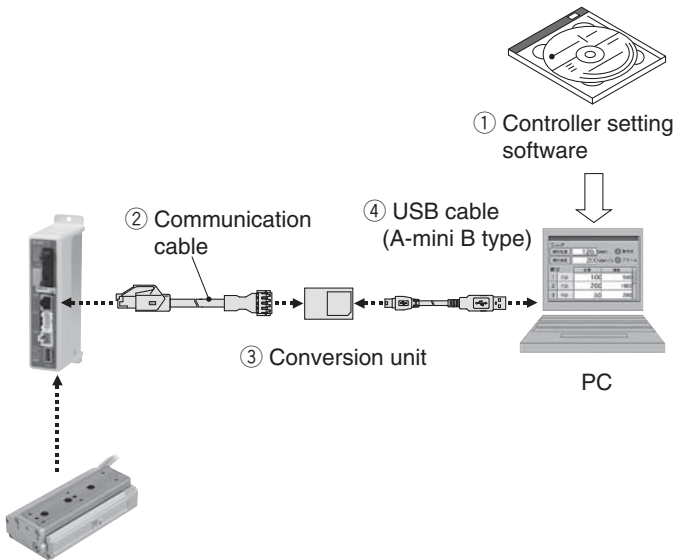

Hardware Requirements

PC/AT compatible machine installed with Windows XP and equipped with USB1.1 or USB2.0 ports.

* Windows® and Windows XP® are registered trademarks of Microsoft Corporation.

Screen Example

Easy mode screen example

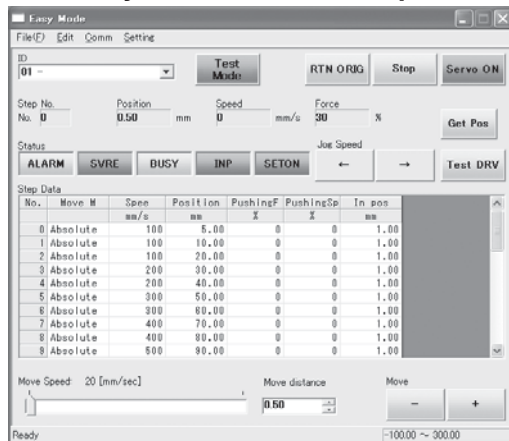

Easy operation and simple setting

- Allowing to set and display actuator step data such as position, speed, force, etc.
- Setting of step data and testing of the drive can be performed on the same page.
- Can be used to jog and move at a constant rate.

Normal mode screen example

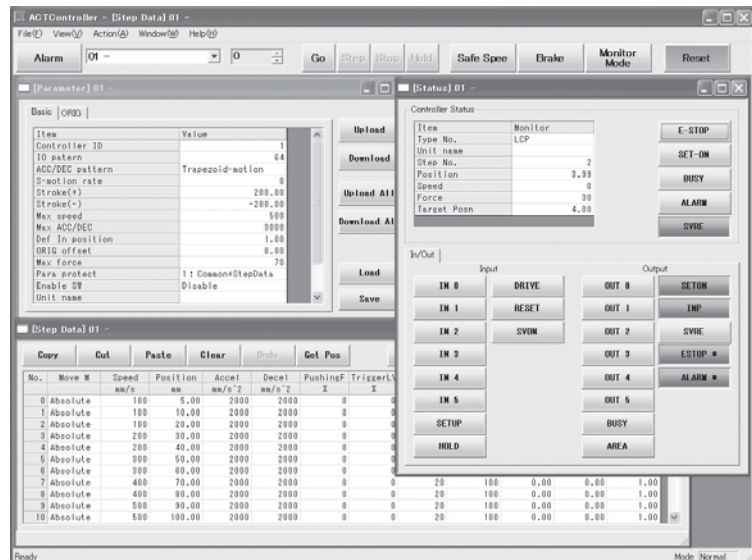

Detail setting

- Step data can be set in detail.
- Signals and terminal status can be monitored.
- Parameters can be set.
- JOG and constant rate movement, return to origin, test operation and testing of compulsory output can be performed.

Series LEC Teaching Box/LEC-T1



How to Order



LEC-T1-3EG

Teaching box

Cable length [m]
3 3

Initial language

J	Japanese
E	English

Enable switch

—	None
S	Equipped with enable switch

* Interlock switch for jog test function

Stop switch

G	Equipped with stop switch
---	---------------------------

Specifications

Standard functions

- Chinese character display
- Stop switch is provided.

Option

- Enable switch is provided.

Item	Description
Switch	Stop switch, Enable switch (Option)
Cable length [m]	3
Enclosure	IP64 (Except connector)
Operating temperature range [°C]	5 to 50
Operating humidity range [%RH]	90 or less (No condensation)
Weight [g]	350 (Except cable)

Note) CE-compliance

The EMC compliance of the teaching box was tested with the LEC-P6 series step motor controller (servo/24 VDC) and an applicable actuator.

Easy Mode

Function	Description
Step data	• Setting of step data
Jog	• Jog operation • Return to origin
Test	• 1 step operation • Return to origin
Monitor	• Display of axis and step data No. • Display of two items selected from Position, Speed, Force.
Alarm	• Display of active alarm • Alarm reset
TB setting	• Reconnection of axis • Setting of easy/normal mode • Setting step data and selection of items from easy mode monitor

Menu Operations Flowchart

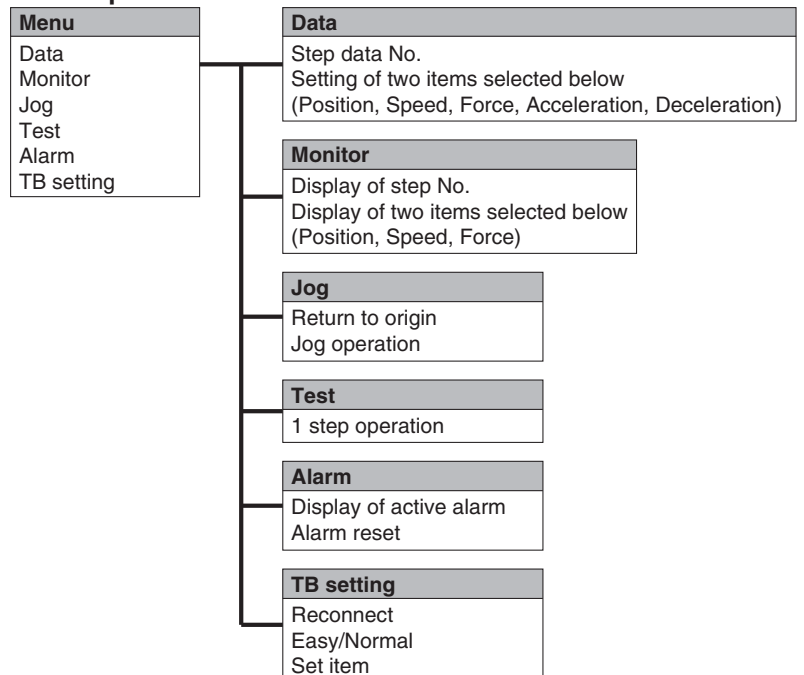

Normal Mode

Function	Description
Step data	• Step data setting
Parameter	• Parameters setting
Test	<ul style="list-style-type: none"> • Jog operation/Constant rate movement • Return to origin • Test drive (Specify a maximum of 5 step data and operate.) • Compulsory output (Compulsory signal output, Compulsory terminal output)
Monitor	<ul style="list-style-type: none"> • Drive monitor • Output signal monitor • Input signal monitor • Output terminal monitor • Input terminal monitor
Alarm	<ul style="list-style-type: none"> • Active alarm display (Alarm reset) • Alarm log record display
File	<ul style="list-style-type: none"> • Data saving Save the step data and parameters of the controller which is being used for communication (it is possible to save four files, with one set of step data and parameters defined as one file). • Load to controller Loads the data which is saved in the teaching box to the controller which is being used for communication. • Delete the saved data.
TB setting	<ul style="list-style-type: none"> • Display setting (Easy/Normal mode) • Language setting (Japanese/English) • Backlight setting • LCD contrast setting • Beep sound setting • Max. connection axis • Distance unit (mm/inch)
Reconnect	• Reconnection of axis

Menu Operations Flowchart

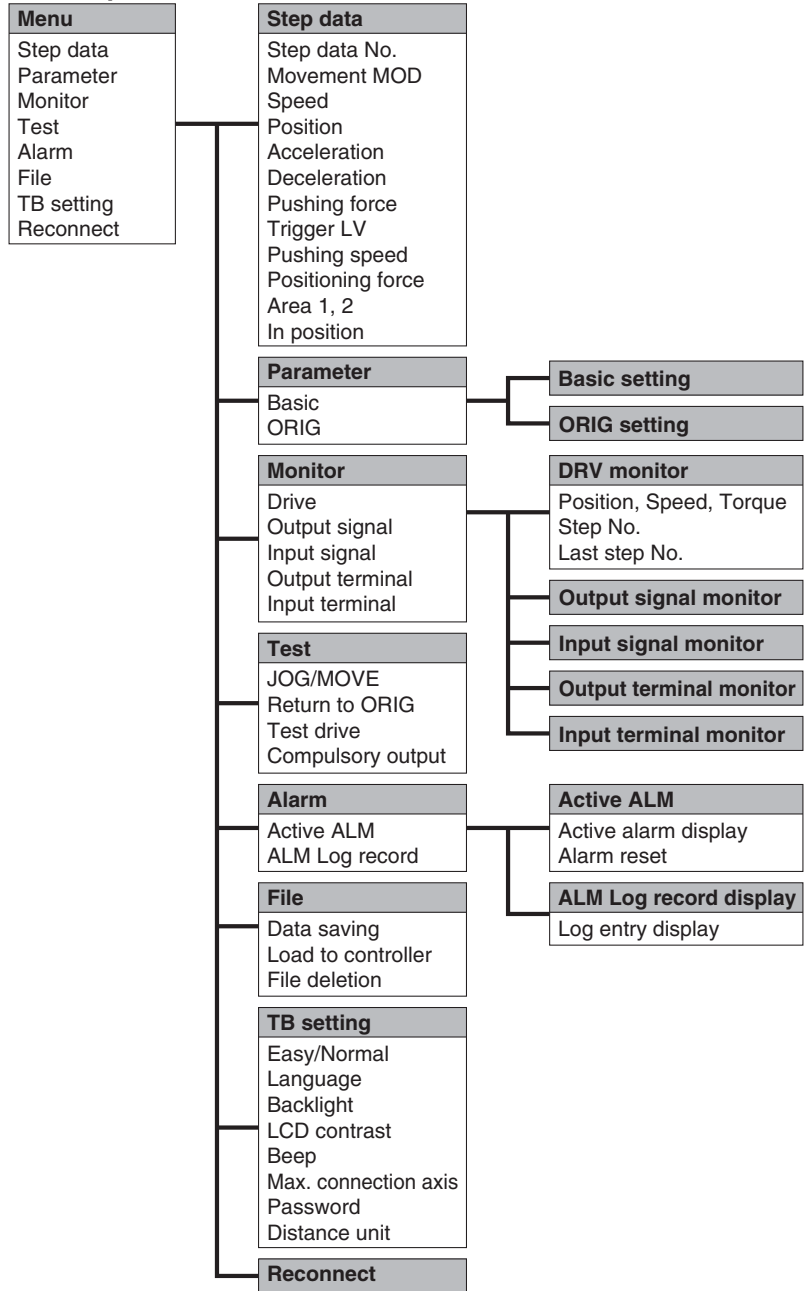

Dimensions

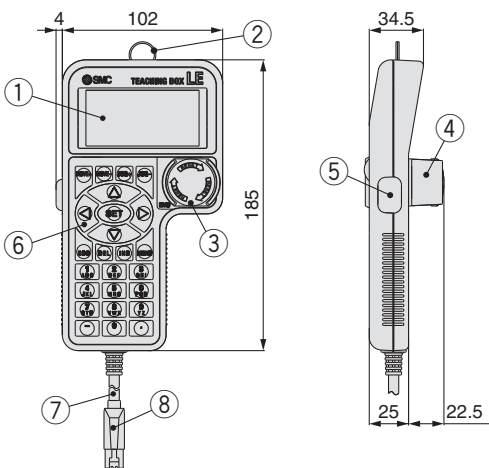

No.	Description	Function
1	LCD	A screen of liquid crystal display (with backlight)
2	Ring	A ring for hanging the teaching box
3	Stop switch	When switch is pushed in, the switch locks and stops. The lock is released when it is turned to the right.
4	Stop switch guard	A guard for the stop switch
5	Enable switch (Option)	Prevents unintentional operation (unexpected operation) of the jog test function. Other functions such as data change are not covered.
6	Key switch	Switch for each input
7	Cable	Length: 3 meters
8	Connector	A connector connected to CN4 of the controller

Programless Controller Series *LECP1*



How to Order

LECP1 P1 - LESH8RJ-50

Controller

Compatible motor

P	Step motor (Servo/24 VDC)
----------	---------------------------

Number of step data (Points)

1	14 (Programless)
----------	------------------

I/O cable length [m]

—	Without cable
1	1.5
3	3
5	5

Parallel I/O type

N	NPN
P	PNP

Actuator part number

(Except cable specifications and actuator options)
Example: Enter [LESH8RJ-50] for
LESH8RJ-50B-R16N1

*** When placing an order for the controller with an actuator, this part number is not necessary.**

The controller is sold as single unit after the compatible actuator is set.

Confirm that the combination of the controller and the actuator is correct.

* Refer to the operation manual for using the products. Please download it via our website. <http://www.smcworld.com>

Specifications

Basic Specifications

Item	LECP1
Compatible motor	Step motor (Servo/24 VDC)
Power supply ^{Note 1)}	Power supply voltage: 24 VDC ±10% Max. current consumption: 3A (Peak 5A) ^{Note 2)} [Including the motor drive power, control power supply, stop, lock release]
Parallel input	6 inputs (Photo-coupler isolation)
Parallel output	6 outputs (Photo-coupler isolation)
Stop points	14 points (Position number 1 to 14(E))
Compatible encoder	Incremental A/B phase (800 pulse/rotation)
Serial communication	RS485 (Modbus protocol compliant)
Memory	EEPROM
LED indicator	LED (Green/Red) one of each
7-segment LED display ^{Note 3)}	1 digit, 7-segment display (red) Figures are expressed in hexadecimal ("10" to "15" in decimal number are expressed as "A" to "F")
Lock control	Forced-lock release terminal ^{Note 4)}
Cable length [m]	I/O cable: 5 or less Actuator cable: 20 or less
Cooling system	Natural air cooling
Operating temperature range [°C]	0 to 40 (No freezing)
Operating humidity range [%RH]	90 or less (No condensation)
Storage temperature range [°C]	-10 to 60 (No freezing)
Storage humidity range [%RH]	90 or less (No condensation)
Insulation resistance [MΩ]	Between the housing (radiation fin) and SG terminal 50 (500 VDC)
Weight [g]	130

Note 1) Do not use the power supply of "inrush current prevention type" for the controller input power supply.

Note 2) The power consumption changes depending on the actuator model. Refer to the each actuator's operation manual etc. for details.

Note 3) "10" to "15" in decimal number are displayed as follows in the 7-segment LED.



Decimal display	10	11	12	13	14	15
Hexadecimal display	A	b	c	d	E	F

Note 4) Applicable to non-magnetizing lock.

Details of The Controller

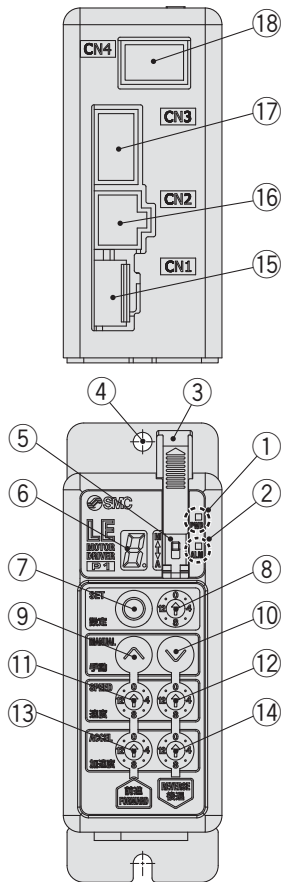

No.	Display	Description	Details
①	PWR	Power supply LED	Power supply ON/servo ON : Green turns on Power supply ON/servo OFF : Green flashes
②	ALM	Alarm LED	With alarm : Red turns on Parameter setting : Red flashes
③	—	Cover	Change and protection of the mode SW (Close the cover after changing SW)
④	—	FG	Frame ground (Tighten the bolt with the nut when mounting the controller. Connect the ground wire.)
⑤	—	Mode switch	Switch the mode between manual and auto.
⑥	—	7-segment LED	Stop position, the value set by ⑧ and alarm information are displayed.
⑦	SET	Set button	Decide the settings or drive operation in Manual mode.
⑧	—	Position selecting switch	Assign the position to drive (1 to 14), and the origin position (15).
⑨	MANUAL	Manual forward button	Perform forward jog and inching.
⑩		Manual reverse button	Perform reverse jog and inching.
⑪	SPEED	Forward speed switch	16 forward speeds are available.
⑫		Reverse speed switch	16 reverse speeds are available.
⑬	ACCEL	Forward acceleration switch	16 forward acceleration steps are available.
⑭		Reverse acceleration switch	16 reverse acceleration steps are available.
⑮	CN1	Power supply connector	Connect the power supply cable.
⑯	CN2	Motor connector	Connect the motor connector.
⑰	CN3	Encoder connector	Connect the encoder connector.
⑱	CN4	I/O connector	Connect I/O cable.

How to Mount

Controller mounting shown below.

1. Mounting screw (LECP1□□-□) (Installation with two M4 screws)

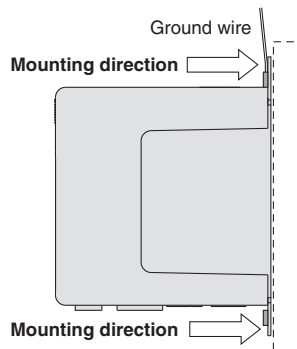

2. Grounding

Tighten the bolt with the nut when mounting the ground wire as shown below.

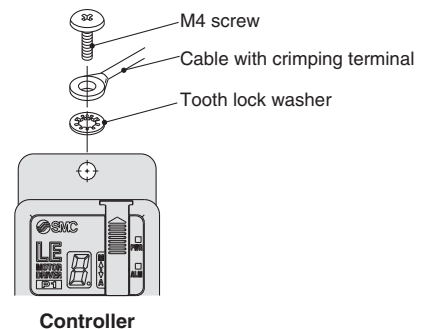

⚠ Caution

- M4 screws, cable with crimping terminal and tooth lock washer are not included. Be sure to carry out grounding earth in order to ensure the noise tolerance.
- Use a watchmaker's screwdriver of the size shown below when changing position switch ⑧ and the set value of the speed/acceleration switch ⑪ to ⑭.

Size

End width **L** : 2.0 to 2.4 [mm]

End thickness **W** : 0.5 to 0.6 [mm]

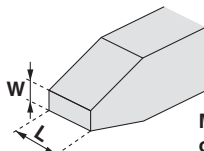

Magnified view of the end of the screwdriver

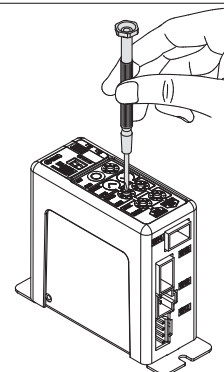

Series LECP1

Dimensions

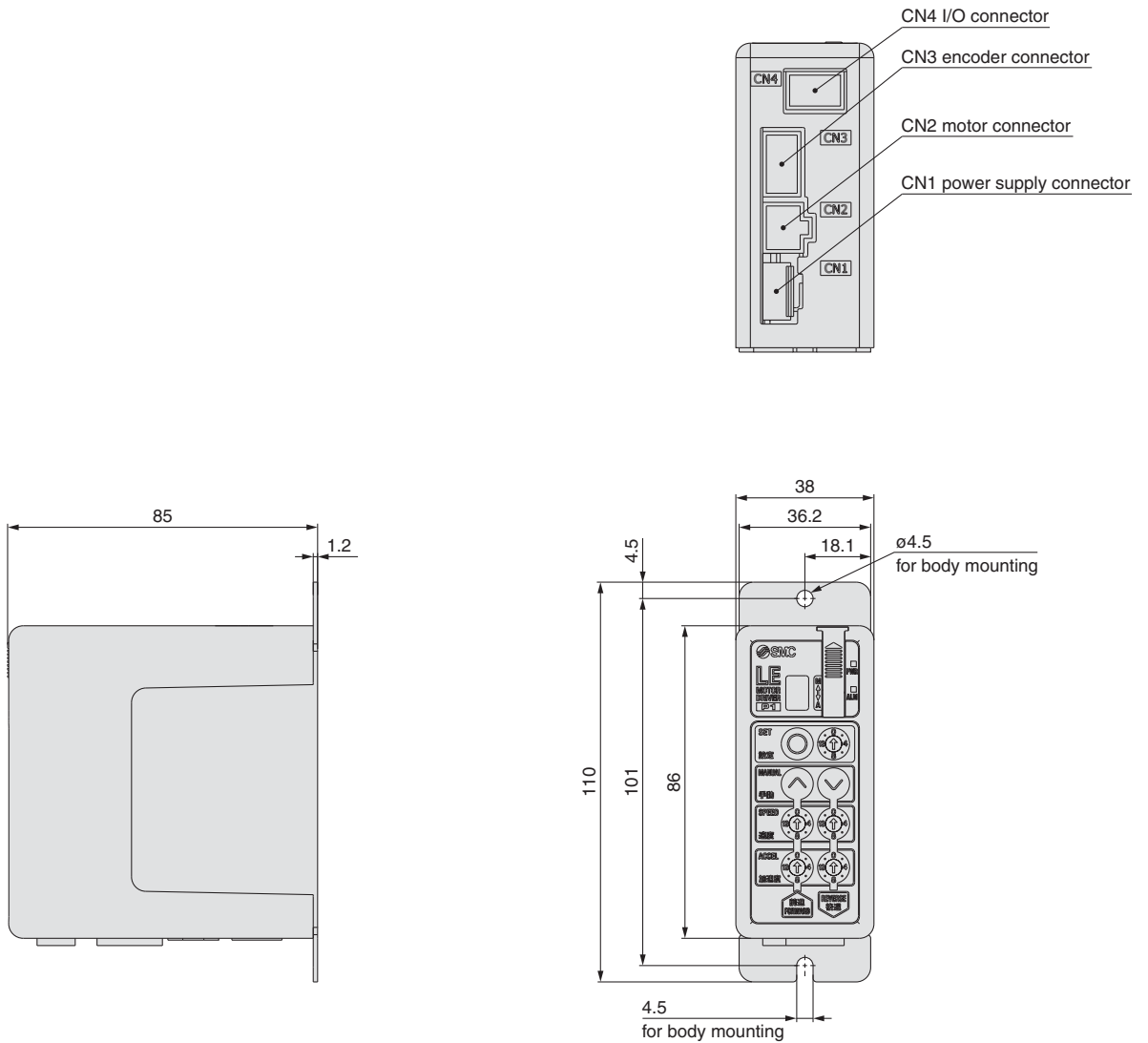

Wiring Example 1

Power Supply Connector: CN1 * When you connect a CN1 power supply connector, please use the power supply cable (LEC-CK1-1).
 * Power supply cable (LEC-CK1-1) is an accessory.

CN1 Power Supply Connector Terminal for LECP1

Terminal name	Cable colour	Function	Function details
0V	Blue	Common supply (-)	M24V terminal/C24V terminal/BK RLS terminal are common (-).
M24V	White	Motor power supply (+)	This is the motor power supply (+) that is supplied to the controller.
C24V	Brown	Control power supply (+)	This is the control power supply (+) that is supplied to the controller.
BK RLS	Black	Lock release (+)	This is the input (+) that releases the lock.

Power supply cable for LECP1 (LEC-CK1-1)

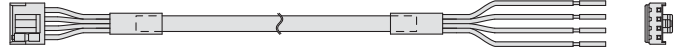

Wiring Example 2

Parallel I/O Connector: CN4 * When you connect a PLC, etc., to the CN4 parallel I/O connector, please use the I/O cable (LEC-CK4-□).
 * The wiring should be changed depending on the type of the parallel I/O (NPN or PNP). Please wire referring to the following diagram.

■NPN

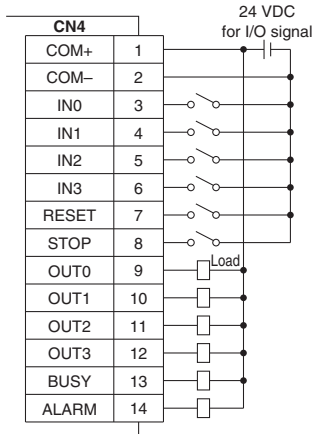

■PNP

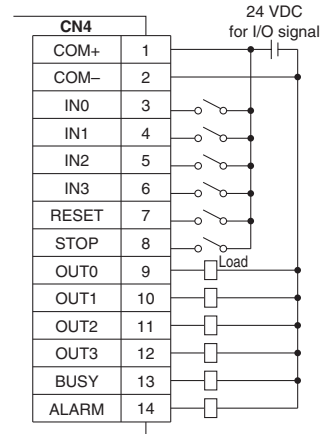

Input Signal

Name	Contents								
COM+	Connects the power supply 24 V for input/output signal								
COM-	Connects the power supply 0 V for input/output signal								
IN0 to IN3	Ç Instruction to drive (input as a combination of IN0 to IN3) Ç Instruction to return to the origin position (IN0 to IN3 all ON simultaneously) Example - (instruction to drive for position no. 5) <table border="1" style="margin-left: 20px;"> <thead> <tr> <th>IN3</th> <th>IN2</th> <th>IN1</th> <th>IN0</th> </tr> </thead> <tbody> <tr> <td>OFF</td> <td>ON</td> <td>OFF</td> <td>ON</td> </tr> </tbody> </table>	IN3	IN2	IN1	IN0	OFF	ON	OFF	ON
IN3	IN2	IN1	IN0						
OFF	ON	OFF	ON						
RESET	Alarm reset and operation interruption During operation : deceleration stop from position at which signal is input (servo ON maintained) While alarm is active : alarm reset								
STOP	Instruction to stop (after maximum deceleration stop, servo OFF)								

Output Signal

Name	Contents								
OUT0 to OUT3	Turns ON when the positioning or pushing is completed. (Output is instructed in the combination of OUT0 to 3.) Example - (operation complete for position no. 3) <table border="1" style="margin-left: 20px;"> <thead> <tr> <th>OUT3</th> <th>OUT2</th> <th>OUT1</th> <th>OUT0</th> </tr> </thead> <tbody> <tr> <td>OFF</td> <td>OFF</td> <td>ON</td> <td>ON</td> </tr> </tbody> </table>	OUT3	OUT2	OUT1	OUT0	OFF	OFF	ON	ON
OUT3	OUT2	OUT1	OUT0						
OFF	OFF	ON	ON						
BUSY	Outputs when the actuator is moving								
*ALARM (Note)	Not output when alarm is active or servo OFF								

Note) These signals are output when the power supply of the controller is ON. (N.C.)

Input Signal [IN0 - IN3] Position Number Chart ○: OFF ●: ON

Position number	IN3	IN2	IN1	IN0
1	○	○	○	●
2	○	○	●	○
3	○	○	●	●
4	○	●	○	○
5	○	●	○	●
6	○	●	●	○
7	○	●	●	●
8	●	○	○	○
9	●	○	○	●
10 (A)	●	○	●	○
11 (B)	●	○	●	●
12 (C)	●	●	○	○
13 (D)	●	●	○	●
14 (E)	●	●	●	○
Return to origin	●	●	●	●

Output Signal [OUT0 - OUT3] Position Number Chart ○: OFF ●: ON

Position number	OUT3	OUT2	OUT1	OUT0
1	○	○	○	●
2	○	○	●	○
3	○	○	●	●
4	○	●	○	○
5	○	●	○	●
6	○	●	●	○
7	○	●	●	●
8	●	○	○	○
9	●	○	○	●
10 (A)	●	○	●	○
11 (B)	●	○	●	●
12 (C)	●	●	○	○
13 (D)	●	●	○	●
14 (E)	●	●	●	○
Return to origin	●	●	●	●

Series LECP1

Signal Timing

(1) Return to Origin

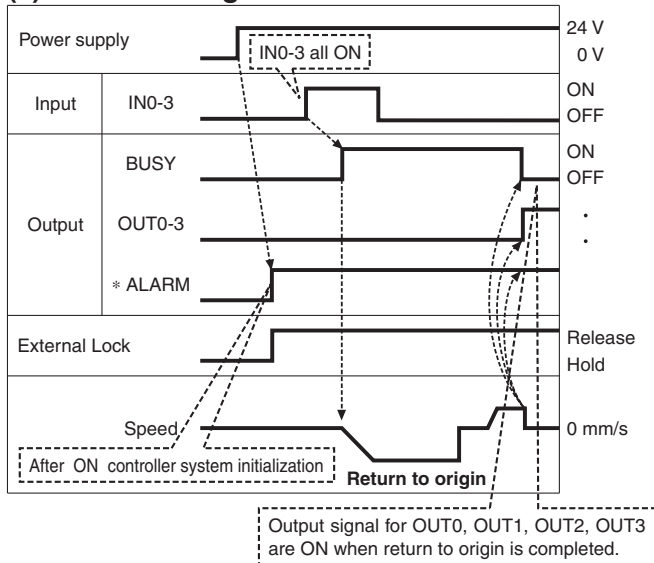

* *ALARM" is expressed as negative-logic circuit.

(2) Positioning Operation

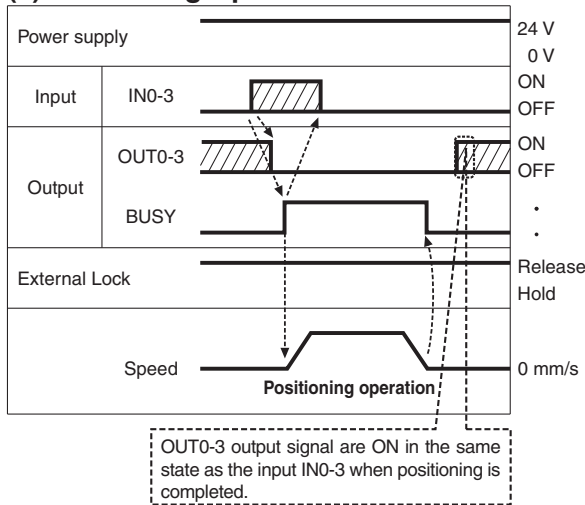

(4) Stop by The STOP Signal

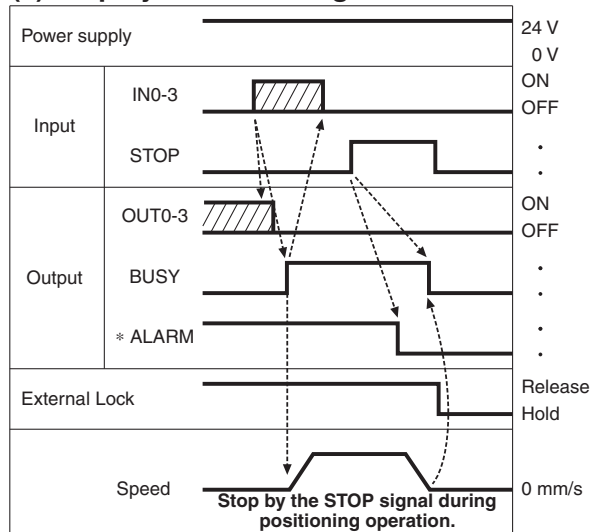

(3) Cut-off Stop (Reset Stop)

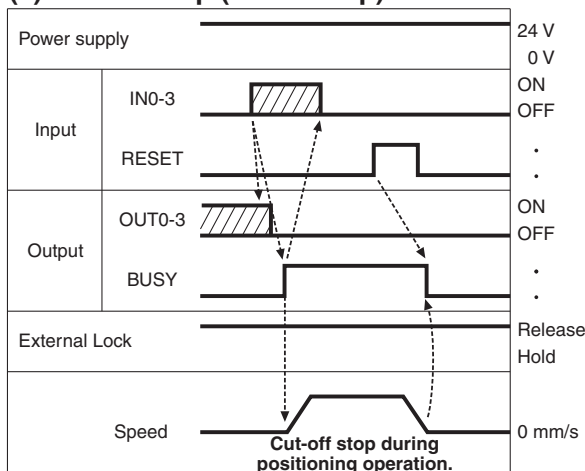

(5) Alarm Reset

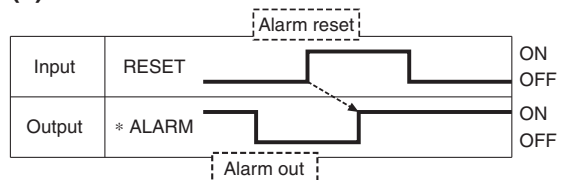

* *ALARM" is expressed as negative-logic circuit.

Options: Actuator Cable

[Robotic cable for step motor (Servo/24 VDC), standard cable]

LE-CP-1-□

Cable length (L)[m]

1	1.5
3	3
5	5
8	8*
A	10*
B	15*
C	20*

* Produced upon receipt of order (Robotic cable only)

Cable type

—	Robotic cable (Flexible cable)
S	Standard cable

LE-CP- $\frac{1}{5}$ / Cable length: 1.5 m, 3 m, 5 m

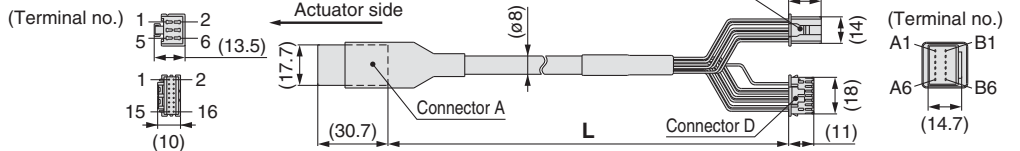

LE-CP- $\frac{8}{AC}$ / Cable length: 8 m, 10 m, 15 m, 20 m
(* Produced upon receipt of order)

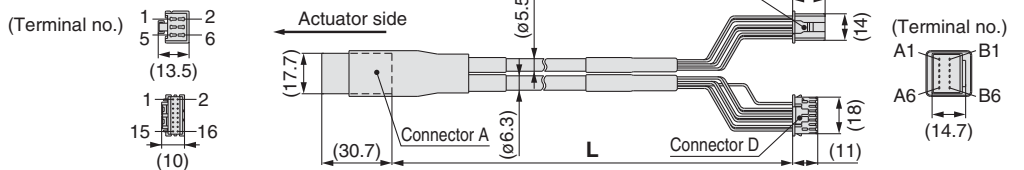

Circuit	Connector A terminal no.	Cable colour	Connector C terminal no.
A	B-1	Brown	2
\bar{A}	A-1	Red	1
B	B-2	Orange	6
\bar{B}	A-2	Yellow	5
COM-A/COM	B-3	Green	3
COM-B/-	A-3	Blue	4
Shield			
Vcc	B-4	Brown	12
GND	A-4	Black	13
\bar{A}	B-5	Red	7
A	A-5	Black	6
\bar{B}	B-6	Orange	9
B	A-6	Black	8
		—	3

[Robotic cable with lock and sensor for step motor (Servo/24 VDC), standard cable]

LE-CP-1-B-□

Cable length (L)[m]

1	1.5
3	3
5	5
8	8*
A	10*
B	15*
C	20*

* Produced upon receipt of order (Robotic cable only)

With lock and sensor

Cable type

—	Robotic cable (Flexible cable)
S	Standard cable

LE-CP- $\frac{1}{5}$ / Cable length: 1.5 m, 3 m, 5 m

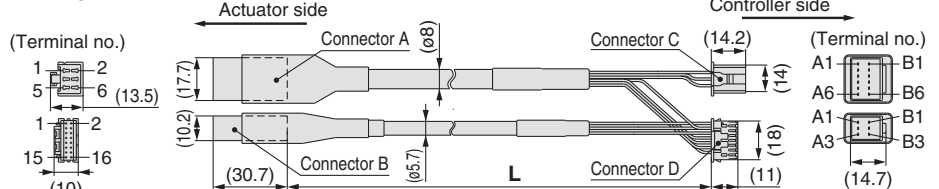

LE-CP- $\frac{8}{AC}$ / Cable length: 8 m, 10 m, 15 m, 20 m
(* Produced upon receipt of order)

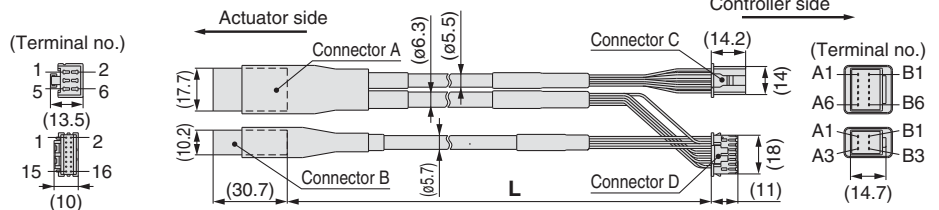

Circuit	Connector A terminal no.	Cable colour	Connector C terminal no.
A	B-1	Brown	2
\bar{A}	A-1	Red	1
B	B-2	Orange	6
\bar{B}	A-2	Yellow	5
COM-A/COM	B-3	Green	3
COM-B/-	A-3	Blue	4
Shield			
Vcc	B-4	Brown	12
GND	A-4	Black	13
\bar{A}	B-5	Red	7
A	A-5	Black	6
\bar{B}	B-6	Orange	9
B	A-6	Black	8
		—	3

Circuit	Connector B terminal no.	Cable colour	Connector D terminal no.
Lock (+)	B-1	Red	4
Lock (-)	A-1	Black	5
Sensor (+) Note)	B-3	Brown	1
Sensor (-) Note)	A-3	Blue	2

Note) This is not used for the LES series.

Series LECP1

Options

[Power supply cable]

LEC-CK1-1



Terminal name	Covered colour	Function
0V	Blue	Common supply (-)
M24V	White	Motor power supply (+)
C24V	Brown	Control power supply (+)
BK RLS	Black	Lock release (+)

* Conductor size: AWG20

[I/O cable]

LEC-CK4-

Cable length (L) [m]

1	1.5
3	3
5	5

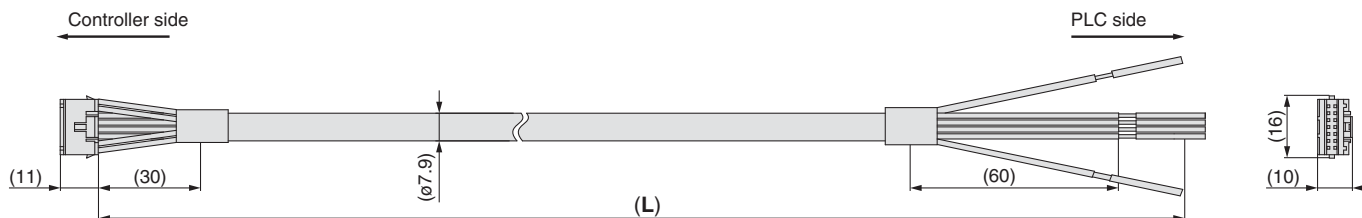



Terminal no.	Insulation colour	Dot mark	Dot colour	Function
1	Light brown	■	Black	COM +
2	Light brown	■	Red	COM -
3	Yellow	■	Black	OUT0
4	Yellow	■	Red	OUT1
5	Light green	■	Black	OUT2
6	Light green	■	Red	OUT3
7	Grey	■	Black	BUSY
8	Grey	■	Red	ALARM
9	White	■	Black	IN0
10	White	■	Red	IN1
11	Light brown	■ ■	Black	IN2
12	Light brown	■ ■	Red	IN3
13	Yellow	■ ■	Black	RESET
14	Yellow	■ ■	Red	STOP

* Conductor size: AWG26

* Parallel I/O signal is valid in auto mode. While the test function operates at manual mode, only the output is valid.

Safety Instructions

These safety instructions are intended to prevent hazardous situations and/or equipment damage. These instructions indicate the level of potential hazard with the labels of “**Caution**,” “**Warning**” or “**Danger**.” They are all important notes for safety and must be followed in addition to International Standards (ISO/IEC)*1), and other safety regulations.

-  **Caution:** **Caution** indicates a hazard with a low level of risk which, if not avoided, could result in minor or moderate injury.
-  **Warning:** **Warning** indicates a hazard with a medium level of risk which, if not avoided, could result in death or serious injury.
-  **Danger:** **Danger** indicates a hazard with a high level of risk which, if not avoided, will result in death or serious injury.

- *1) ISO 4414: Pneumatic fluid power – General rules relating to systems.
ISO 4413: Hydraulic fluid power – General rules relating to systems.
IEC 60204-1: Safety of machinery – Electrical equipment of machines.
(Part 1: General requirements)
ISO 10218-1: Manipulating industrial robots - Safety.
etc.

Warning

- 1. The compatibility of the product is the responsibility of the person who designs the equipment or decides its specifications.**
Since the product specified here is used under various operating conditions, its compatibility with specific equipment must be decided by the person who designs the equipment or decides its specifications based on necessary analysis and test results. The expected performance and safety assurance of the equipment will be the responsibility of the person who has determined its compatibility with the product. This person should also continuously review all specifications of the product referring to its latest catalogue information, with a view to giving due consideration to any possibility of equipment failure when configuring the equipment.
- 2. Only personnel with appropriate training should operate machinery and equipment.**
The product specified here may become unsafe if handled incorrectly. The assembly, operation and maintenance of machines or equipment including our products must be performed by an operator who is appropriately trained and experienced.
- 3. Do not service or attempt to remove product and machinery/equipment until safety is confirmed.**
 1. The inspection and maintenance of machinery/equipment should only be performed after measures to prevent falling or runaway of the driven objects have been confirmed.
 2. When the product is to be removed, confirm that the safety measures as mentioned above are implemented and the power from any appropriate source is cut, and read and understand the specific product precautions of all relevant products carefully.
 3. Before machinery/equipment is restarted, take measures to prevent unexpected operation and malfunction.
- 4. Contact SMC beforehand and take special consideration of safety measures if the product is to be used in any of the following conditions.**
 1. Conditions and environments outside of the given specifications, or use outdoors or in a place exposed to direct sunlight.
 2. Installation on equipment in conjunction with atomic energy, railways, air navigation, space, shipping, vehicles, military, medical treatment, combustion and recreation, or equipment in contact with food and beverages, emergency stop circuits, clutch and brake circuits in press applications, safety equipment or other applications unsuitable for the standard specifications described in the product catalogue.
 3. An application which could have negative effects on people, property, or animals requiring special safety analysis.
 4. Use in an interlock circuit, which requires the provision of double interlock for possible failure by using a mechanical protective function, and periodical checks to confirm proper operation.

Caution

- 1. The product is provided for use in manufacturing industries.**
The product herein described is basically provided for peaceful use in manufacturing industries.
If considering using the product in other industries, consult SMC beforehand and exchange specifications or a contract if necessary.
If anything is unclear, contact your nearest sales branch.

Limited warranty and Disclaimer/ Compliance Requirements

The product used is subject to the following “Limited warranty and Disclaimer” and “Compliance Requirements”.

Read and accept them before using the product.

Limited warranty and Disclaimer

1. The warranty period of the product is 1 year in service or 1.5 years after the product is delivered, whichever is first.*2)
Also, the product may have specified durability, running distance or replacement parts. Please consult your nearest sales branch.
2. For any failure or damage reported within the warranty period which is clearly our responsibility, a replacement product or necessary parts will be provided.
This limited warranty applies only to our product independently, and not to any other damage incurred due to the failure of the product.
3. Prior to using SMC products, please read and understand the warranty terms and disclaimers noted in the specified catalogue for the particular products.

*2) Vacuum pads are excluded from this 1 year warranty.

A vacuum pad is a consumable part, so it is warranted for a year after it is delivered. Also, even within the warranty period, the wear of a product due to the use of the vacuum pad or failure due to the deterioration of rubber material are not covered by the limited warranty.

Compliance Requirements

1. The use of SMC products with production equipment for the manufacture of weapons of mass destruction (WMD) or any other weapon is strictly prohibited.
2. The exports of SMC products or technology from one country to another are governed by the relevant security laws and regulations of the countries involved in the transaction. Prior to the shipment of a SMC product to another country, assure that all local rules governing that export are known and followed.

Safety Instructions

Be sure to read “Handling Precautions for SMC Products” (M-E03-3) before using.

SMC Corporation (Europe)

Austria	☎ +43 (0)2262622800	www.smc.at	office@smc.at
Belgium	☎ +32 (0)33551464	www.smc-pneumatics.be	info@smc-pneumatics.be
Bulgaria	☎ +359 (0)2807670	www.smc.bg	office@smc.bg
Croatia	☎ +385 (0)13707288	www.smc.hr	office@smc.hr
Czech Republic	☎ +420 541424611	www.smc.cz	office@smc.cz
Denmark	☎ +45 70252900	www.smc-dk.com	smc@smc-dk.com
Estonia	☎ +372 6510370	www.smc-pneumatics.ee	smc@smc-pneumatics.ee
Finland	☎ +358 207513513	www.smc.fi	smc-fi@smc.fi
France	☎ +33 (0)164761000	www.smc-france.fr	promotion@smc-france.fr
Germany	☎ +49 (0)61034020	www.smc.de	info@smc.de
Greece	☎ +30 210 2717265	www.smc-hellas.gr	sales@smc-hellas.gr
Hungary	☎ +36 23511390	www.smc.hu	office@smc.hu
Ireland	☎ +353 (0)14039000	www.smc-pneumatics.ie	sales@smc-pneumatics.ie
Italy	☎ +39 0292711	www.smc-italia.it	mailbox@smc-italia.it
Latvia	☎ +371 67817700	www.smc-lv.lv	info@smc-lv.lv

Lithuania	☎ +370 5 2308118	www.smclt.lt	info@smclt.lt
Netherlands	☎ +31 (0)205318888	www.smc-pneumatics.nl	info@smc-pneumatics.nl
Norway	☎ +47 67129020	www.smc-norge.no	post@smc-norge.no
Poland	☎ +48 (0)222119616	www.smc.pl	office@smc.pl
Portugal	☎ +351 226166570	www.smc.eu	postpt@smc.smces.es
Romania	☎ +40 213205111	www.smcromania.ro	smcromania@smcromania.ro
Russia	☎ +7 8127185445	www.smc-pneumatik.ru	info@smc-pneumatik.ru
Slovakia	☎ +421 (0)413213212	www.smc.sk	office@smc.sk
Slovenia	☎ +386 (0)73885412	www.smc.si	office@smc.si
Spain	☎ +34 902184100	www.smc.eu	post@smc.smces.es
Sweden	☎ +46 (0)86031200	www.smc.nu	post@smc.nu
Switzerland	☎ +41 (0)523963131	www.smc.ch	info@smc.ch
Turkey	☎ +90 212 489 0 440	www.smc-pneumatik.com.tr	info@smc-pneumatik.com.tr
UK	☎ +44 (0)845 121 5122	www.smc-pneumatics.co.uk	sales@smc-pneumatics.co.uk