

Overview ..... 0

Cabinets ..... 1

Wall mounted cases ..... 2

Accessories for cabinets and wall mounted cases .... 3

Climate control .... 4

Desk-top cases .... 5

Subracks/ 19" chassis ..... 6

Front panels, plug-in units ..... 7

Systems ..... 8

Power supply units ..... 9

Backplanes ..... 10

Connectors, front panel component system ..... 11

Appendix ..... 12

## Cabinets - 19" lab racks



01305003

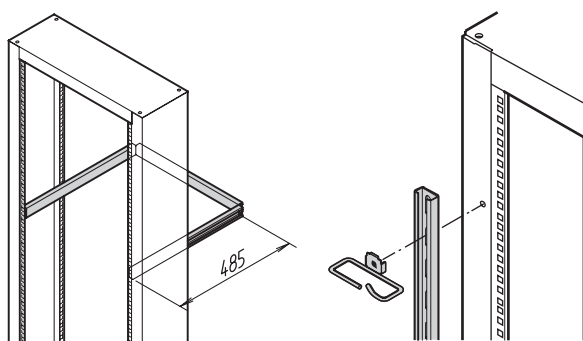

Cable ducting on the front and rear side

Ira45330 vnt007

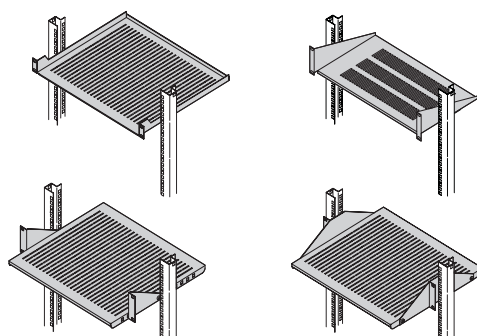

Large selection of equipment shelves

01505050

### Application/function

19" lab racks are freely accessible from all sides. Subracks, 19" cases and 19" shelves can be mounted. Two angled steel uprights are screw-fixed on the base part (mobile base/plinth and base plate respectively). The 19" cut-outs of the steel uprights are recessed so far that a flat surface for front panels is created. The two profiles are connected by a cover plate which gives the rack additional stability.

The base/plinth of the mobile 19" lab rack has two fixed rear castors and two locking castors at the front. The 100 mm roller diameter ensures both good mobility and high stability.

A base plate from sheet steel forms the plinth for the stationary 19" lab rack.

### Standards/certifications

- Internal and external dimensions in accordance with: IEC 60297-3-100



Downloads and further important information can be found on the Internet under [www.schroff.biz](http://www.schroff.biz)



## Cabinets – 19" lab racks

Overview . . . . 1.286

### 19" lab rack

- Mobile or stationary
- Various shelves
- Accessories for cable ducting



01305001

#### Mobile

- 36 U
- Load-carrying capacity up to max. 200 kg

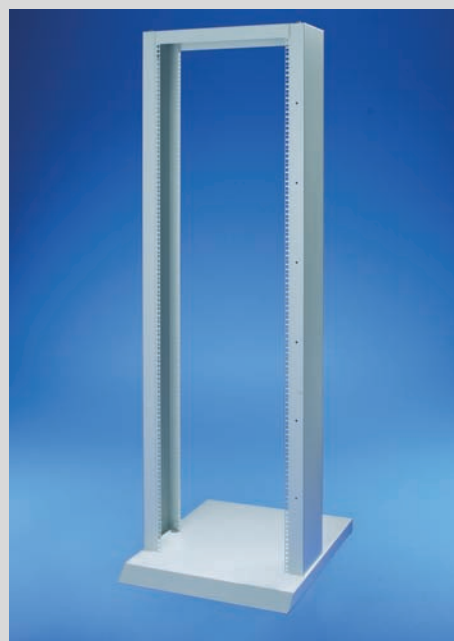

01305002

#### Stationary

- 24 and 39 U
- Load-carrying capacity up to max. 150 kg

### 19" lab racks

19" lab rack, mobile . . . . .	1.288
19" lab rack, stationary . . . . .	1.289
Panel mounts . . . . .	1.290
Cable support rail . . . . .	1.290
C-profiles . . . . .	1.291
Cable eyes for C-profile . . . . .	1.291
19" equipment shelves . . . . .	1.292
Slide rails . . . . .	1.293



30407004

**ServicePLUS from page 1.294**  
 e.g. modifications (special colours)  
 e.g. custom solutions (special sizes)  
[www.schroff.biz/serviceplus/](http://www.schroff.biz/serviceplus/)

ServicePLUS . 1.294



## Cabinets – 19" lab racks

### 19" lab rack, mobile



01305001

- Stationary load-carrying capacity 200 kg, at a defined centre of gravity position in the center of the lab rack
- Recommended max. chassis depth 400 mm

#### Delivery comprises (assembled)

Item	Qty	Description
1	1	19" frame, St, 2 mm, RAL 7035, with EIA cut-outs
2	1	Mobile base/plinth, Al, die-cast, RAL 7035
3	2	Castor, plastic (PA), with rubber insert
4	2	Locking castor, plastic (PA), with rubber insert

#### Order Information

Description	Part no.
19" lab rack, mobile, usable height 36 U	<b>10117-498</b>
19" assembly kit (50 x screws, 50 x washers, 50 x nuts)	<b>21101-809</b>
19" assembly kit (100 x screws, 100 x washers, 100 x nuts)	<b>21101-810</b>



For further information [www.schroff.biz/oneclick](http://www.schroff.biz/oneclick)  
oneClick search code = Part no.

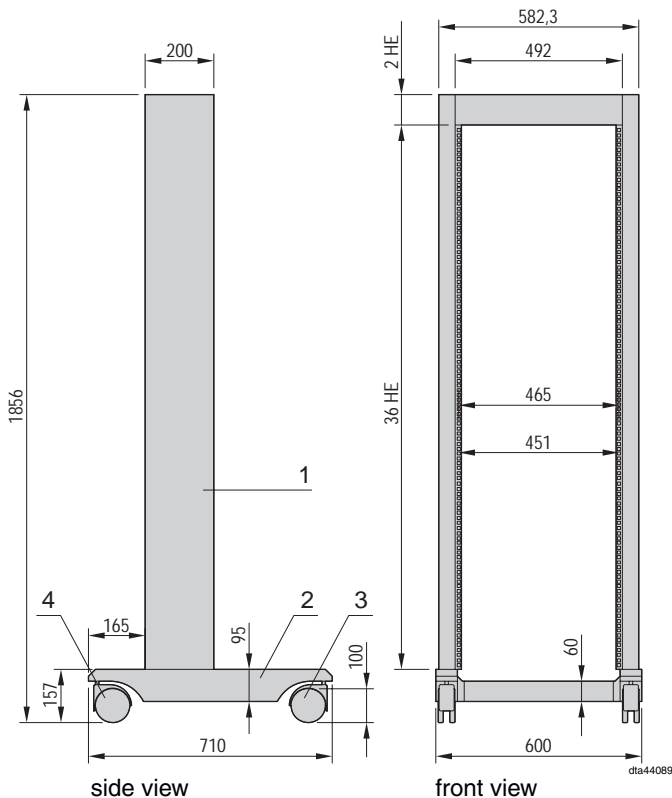

ServicePLUS see page 1.294

# Cabinets – 19" lab racks

## 19" lab rack, stationary



- Modular design with base/plinth and cover plate, please order uprights according to desired height separately
- Stationary load-carrying capacity 150 kg, at a defined centre of gravity in the centre of the lab rack
- Recommended max. chassis depth 400 mm

### Delivery comprises (kit)

Item.	Qty	Description
1	1	Base/plinth, St, 2 mm, RAL 7035
2	1	Top cover plate, St, 1.5 mm, RAL 7035
4	1	Assembly kit

### Order Information

Description	Item	Part no.
Base and top cover plate	1 + 2 + 4	<b>20118-743</b>
<b>Uprights (item 3) with EIA perforation, 24 U, RAL 7035, PU 2 pieces</b>		<b>20118-741</b>
<b>Uprights (item 3) with EIA perforation, 39 U, RAL 7035, PU 2 pieces</b>		<b>20118-742</b>
<b>Adjustable feet load-carrying capacity 100 kg per foot, PU 4 pieces</b>		<b>21190-571</b>
<b>Castors load-carrying capacity 150 kg per kit, castor diameter 52 mm, PU 4 pieces (2 locking, 2 non-locking)</b>		<b>20118-462</b>
<b>19" assembly kit (50 x screws, 50 x washers, 50 x nuts)</b>		<b>21101-809</b>
<b>19" assembly kit (100 x screws, 100 x washers, 100 x nuts)</b>		<b>21101-810</b>

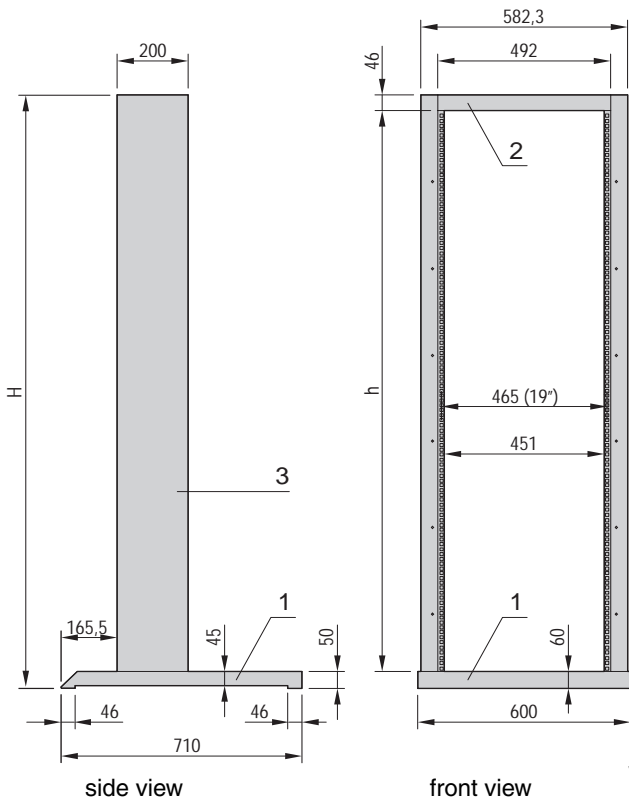

### Technical data

Usable height	h	H
U	mm	mm
24	1067	1164
39	1733	1831

### Note

- Please order uprights separately



For further information [www.schroff.biz/oneclick](http://www.schroff.biz/oneclick)  
oneClick search code = Part no.



ServicePLUS see page 1.294

## Cabinets – 19" lab racks

### C-profile for stationary 19" lab rack

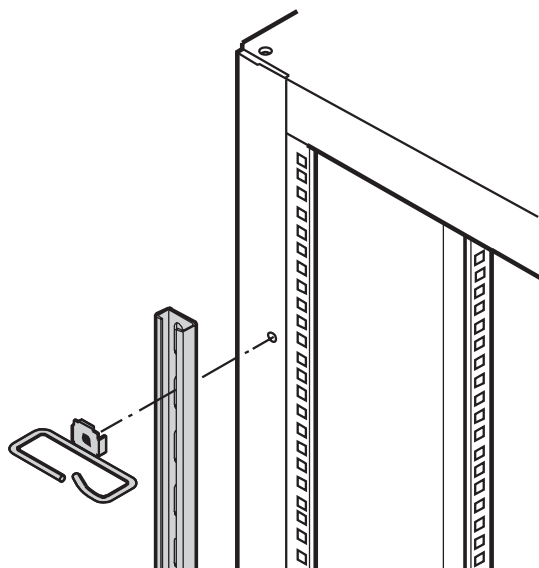

VNT007

- For assembly to the vertical uprights on the right and left hand side of the 19" plane; especially suited for cable eyes

#### Delivery comprises

Item	Qty	Description
1	2	C-profile, St, 1.5 mm, zinc-plated

#### Order Information

Height U	Length mm	Part no.
24	1050	<b>20118-461</b>
39	1650	<b>22114-461</b>
<b>Assembly kit PU 1 kit</b>		<b>21101-175</b>

#### Note

- Please order assembly kit separately
- Not suitable on mobile 19" lab racks



For further information [www.schroff.biz/oneclick](http://www.schroff.biz/oneclick)  
oneClick search code = Part no.

### Cable eye for C-profile

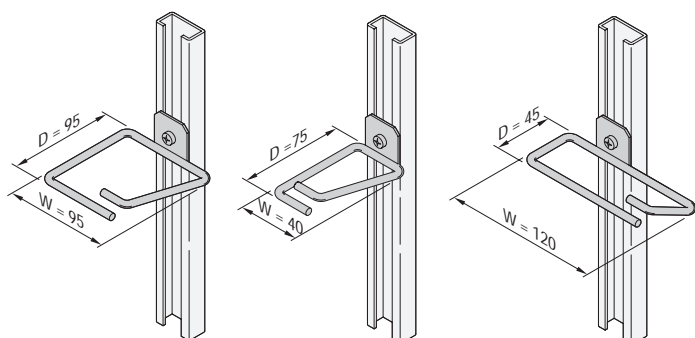

005070500050705100507052

#### Delivery comprises

Item	Qty	Description
1	4	Cable eye, round steel, 6 mm, zinc-plated, with integrated anti-twist device

#### Order Information

Description	W mm	D mm	Part no.
Cable eye for C-profile	120	45	<b>20118-339</b>
Cable eye for C-profile	40	75	<b>20118-554</b>
Cable eye for C-profile	95	95	<b>20118-340</b>
<b>Assembly kit for 4 cable eyes, PU 1 kit</b>			<b>21101-596</b>

#### Note

- Please order assembly kit separately



For further information [www.schroff.biz/oneclick](http://www.schroff.biz/oneclick)  
oneClick search code = Part no.

## Cabinets – 19" lab racks

### 19" equipment shelf, 1 U

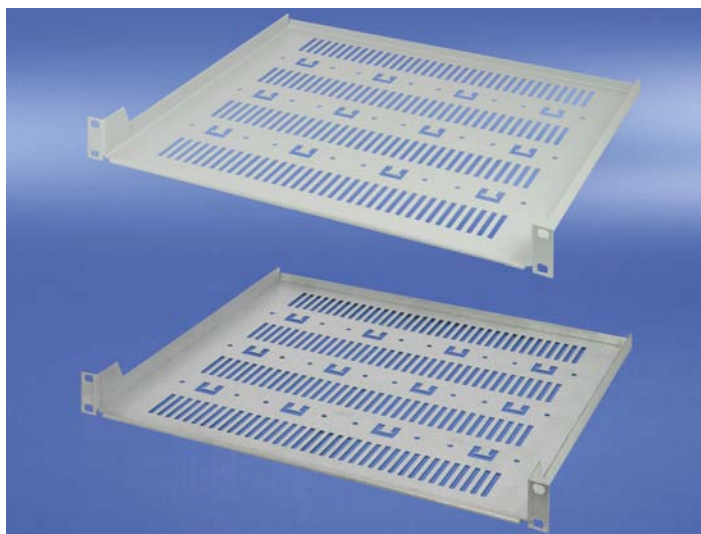

00508012

- Static load-carrying capacity 5 kg
- Mounting height 1 U

**NEW**

#### Delivery comprises

Item	Qty	Description
1	1	Equipment shelf, St, 1.5 mm

#### Order Information

Width B mm	Depth mm	AlZn Part no.	RAL 7035 Part no.
447	390	<b>20118-781</b>	<b>20118-783</b>
19" assembly kit (screw, washer, nut)			<b>21190-095</b>
PU 1 kit, 4 pieces each			

### 19" equipment shelf, 2 U



00508002

- Static load-carrying capacity 10 kg
- Overall mounting height 2 U

**NEW**

#### Delivery comprises

Item	Qty	Description
1	1	Equipment shelf, St, 1.5 mm

#### Order Information

Width B mm	Depth mm	RAL 7035 Part no.
447	238	<b>20118-785</b>
19" assembly kit (screw, washer, nut)		<b>21190-095</b>
PU 1 kit, 4 pieces each		

### 19" equipment shelf, depth-adjustable, 2 U

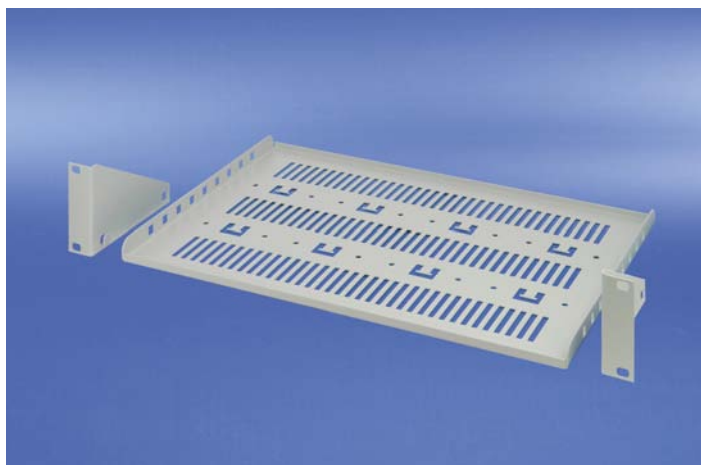

00508009

- Static load-carrying capacity 15 kg
- Overall mounting height 2 U
- Depth-adjustable in 25 mm increments (front protrusion min. 26 mm)

**NEW**

#### Delivery comprises (kit)

Item	Qty	Description
1	1	Equipment shelf, St, 1.5 mm
2	2	Mounting bracket with assembly kit, St, 1.5 mm

#### Order Information

Width B mm	Depth mm	RAL 7035 Part no.
430	250	<b>20118-789</b>
430	300	<b>20118-790</b>
430	400	<b>20118-791</b>
19" assembly kit (screw, washer, nut)		<b>21190-095</b>
PU 1 kit, 4 pieces each		

## Cabinets – 19" lab racks

### 19" equipment shelf with front protrusion, 2 U

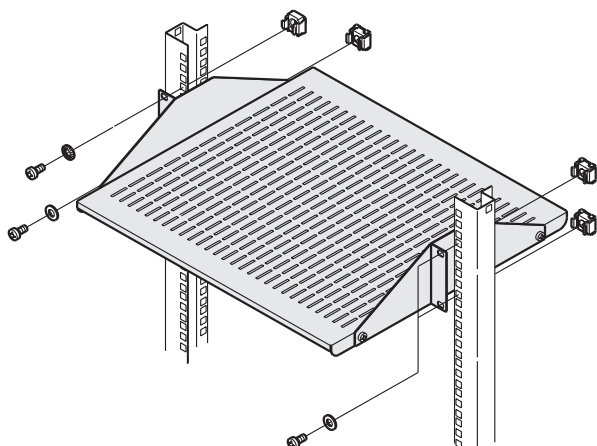

SZA46423

- Load-carrying capacity 25 kg
- Mounting height 2 U
- Front protrusion min. 168 mm

#### Delivery comprises (kit)

Item	Qty	Description
1	1	Equipment shelf, St, 1.5 mm, RAL 7035
2	2	Mounting bracket, strengthened, St, 2/2.5 mm, RAL 7035
3	1	Assembly kit incl. GND/earthing kit

#### Order Information

Width B mm	Depth mm	Part no.
430	400	<b>20119-257</b>



For further information [www.schroff.biz/oneclick](http://www.schroff.biz/oneclick)  
oneClick search code = Part no.

### Slide rail, 40 kg

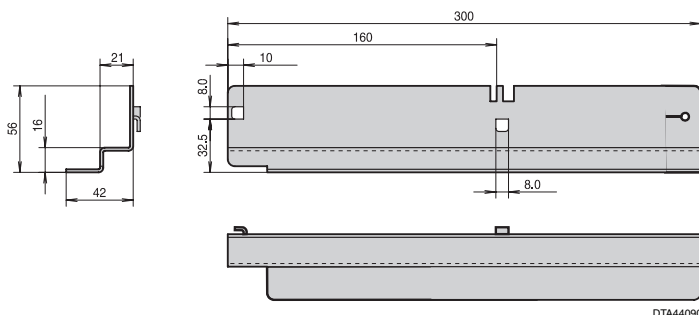

DTA44090

- For assembly on mobile 19" lab racks; with panel mounts also on stationary 19" lab racks
- Static load-carrying capacity 40 kg per pair

#### Delivery comprises

Item	Qty	Description
1	2 / 10	Slide rail, St, 2 mm, zinc-plated

#### Order Information

Description	Qty/PU	Part no.
Slide rail, 40 kg	2	<b>20119-080</b>
Slide rail, 40 kg	10	<b>20119-106</b>

#### Note

- Panel mounts are necessary for assembly on stationary 19" labrack, please order separately, see page 1.290