

**TYPES SN74193, SN74LS193
SN54193, SN54LS193
SYNCHRONOUS 4-BIT UP/DOWN COUNTERS (DUAL CLOCK WITH CLEAR)**

DECEMBER 1972 - REVISED DECEMBER 1983

- Cascading Circuitry Provided Internally
- Synchronous Operation
- Individual Preset to Each Flip-Flop
- Fully Independent Clear Input

SN54193, SN54LS193... J PACKAGE
SN74193... N PACKAGE
SN74LS193...D OR N PACKAGE

(TOP VIEW)

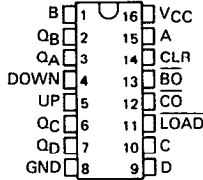

TYPES	TYPICAL MAXIMUM COUNT FREQUENCY	TYPICAL POWER DISSIPATION
'193	32 MHz	325 mW
'LS193	32 MHz	95 mW

description

These monolithic circuits are synchronous reversible (up/down) counters having a complexity of 55 equivalent gates. The '193 and 'LS193 are 4-bit binary counters. Synchronous operation is provided by having all flip-flops clocked simultaneously so that the outputs change coincidentally with each other when so instructed by the steering logic. This mode of operation eliminates the output counting spikes which are normally associated with asynchronous (ripple-clock) counters.

The outputs of the four master-slave flip-flops are triggered by a low-to-high-level transition of either count (clock) input. The direction of counting is determined by which count input is pulsed while the other count input is high.

All four counters are fully programmable; that is, each output may be preset to either level by entering the desired data at the data inputs while the load input is low. The output will change to agree with the data inputs independently of the count pulses. This feature allows the counters to be used as modulo-N dividers by simply modifying the count length with the preset inputs.

A clear input has been provided which forces all outputs to the low level when a high level is applied. The clear function is independent of the count and load inputs. The clear, count, and load inputs are buffered to lower the drive requirements. This reduces the number of clock drivers, etc., required for long words.

These counters were designed to be cascaded without the need for external circuitry. Both borrow and carry outputs are available to cascade both the up- and down-counting functions. The borrow output produces a pulse equal in width to the count-down input when the counter underflows. Similarly, the carry output produces a pulse equal in width to the count-up input when an overflow condition exists. The counters can then be easily cascaded by feeding the borrow and carry outputs to the count-down and count-up inputs respectively of the succeeding counter.

SN54LS192, SN54LS193 ... FK PACKAGE

(TOP VIEW)

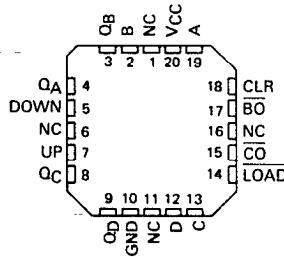

NC - No internal connection

absolute maximum ratings over operating free-air temperature range (unless otherwise noted)

	SN54'	SN54LS'	SN74'	SN74LS'	UNIT
Supply voltage, V_{CC} (see Note 1)	7	7	7	7	V
Input voltage	5.5	7	5.5	7	V
Operating free-air temperature range	- 55 to 125		0 to 70		C
Storage temperature range	- 65 to 150		- 65 to 150		C

NOTE 1: Voltage values are with respect to network ground terminal.

PRODUCTION DATA
This document contains information current as of publication date. Products conform to specifications per the terms of Texas Instruments standard warranty. Production processing does not necessarily include testing of all parameters.



**TYPES SN74193, SN74LS193, SN54193, SN54LS193
 SYNCHRONOUS 4-BIT UP/DOWN COUNTERS (DUAL CLOCK WITH CLEAR)**

logic diagram

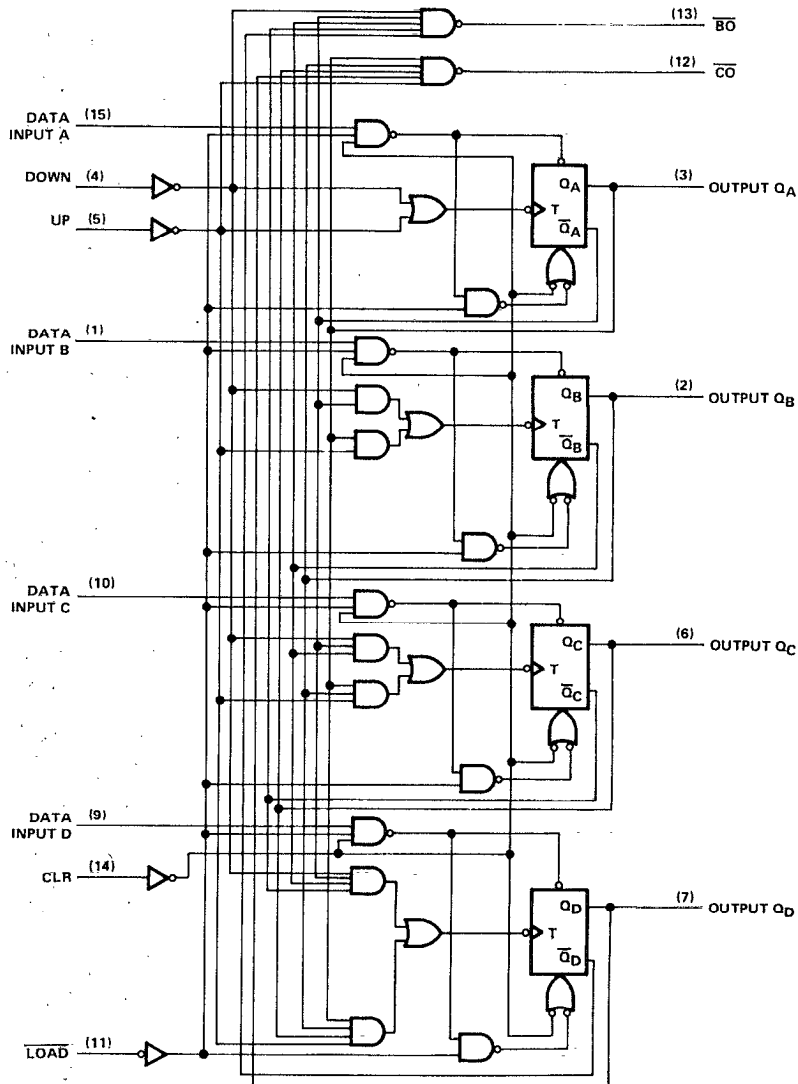

Pin numbers shown on logic notation are for D, J or N packages.

TYPES SN74193, SN74LS193
SN54193, SN54LS193
SYNCHRONOUS 4-BIT COUNTERS (DUAL CLOCK WITH CLEAR)

logic symbols

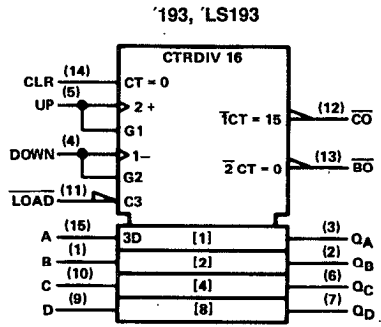

Pin numbers shown on logic notation are for D, J or N packages.

schematics of inputs and outputs

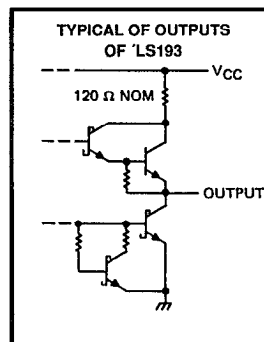
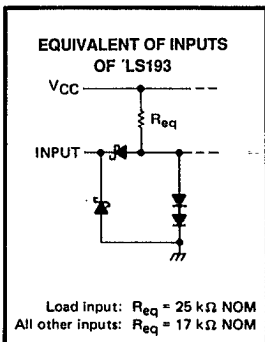
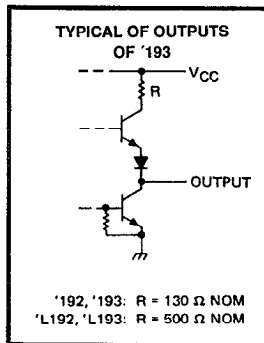
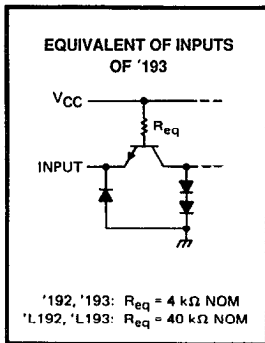

TYPES SN74193, SN74LS193, SN54193, SN54LS193
 SYNCHRONOUS 4-BIT UP/DOWN COUNTERS (DUAL CLOCK WITH CLEAR)

'193, 'LS193 BINARY COUNTERS

typical clear, load, and count sequences

Illustrated below is the following sequence:

1. Clear outputs to zero.
2. Load (preset) to binary thirteen.
3. Count up to fourteen, fifteen, carry, zero, one, and two.
4. Count down to one, zero, borrow, fifteen, fourteen, and thirteen.

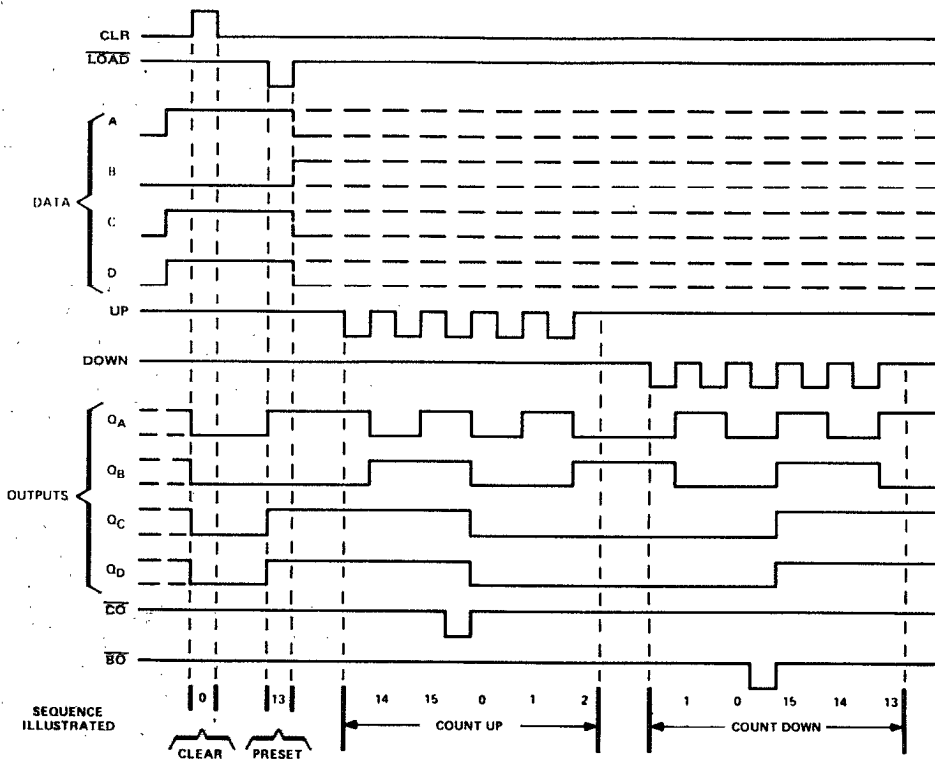

NOTES: A. Clear overrides load, data, and count inputs.
 B. When counting up, count-down input must be high; when counting down, count-up input must be high.

TYPES SN74193, SN54193
SYNCHRONOUS 4-BIT UP/DOWN COUNTERS (DUAL CLOCK WITH CLEAR)

recommended operating conditions

		SN54193			SN74193			UNIT
		MIN	NOM	MAX	MIN	NOM	MAX	
V _{CC}	Supply voltage	4.5	5	5.5	4.75	5	5.25	V
I _{OH}	High-level output current	-0.4			-0.4			mA
I _{OL}	Low-level output current	16			16			mA
f _{clock}	Clock frequency	0	25		0	25		MHz
t _w	Width of any input pulse	20			20			ns
t _{su}	Data setup time, (see Figure 1)	20			20			ns
t _h	Hold time	Data, high or low	0		0		ns	
		LOAD	3		3			
T _A	Operating free-air temperature	-55	125		0	70		°C

electrical characteristics over recommended operating free-air temperature range (unless otherwise noted)

PARAMETER	TEST CONDITIONS†	SN54193			SN74193			UNIT
		MIN	TYP‡	MAX	MIN	TYP‡	MAX	
V _{IH}	High-level input voltage	2			2			V
V _{IL}	Low-level input voltage	0.8			0.8			V
V _{IK}	Input clamp voltage	V _{CC} = MIN, I _I = -12 mA			-1.5			V
V _{OH}	High-level output voltage	V _{CC} = MIN, V _{IH} = 2 V, V _{IL} = 0.8 V, I _{OH} = -0.4 mA			2.4 3.4			V
V _{OL}	Low-level output voltage	V _{CC} = MIN, V _{IH} = 2 V, V _{IL} = 0.8 V, I _{OL} = 16 mA			0.2 0.4			V
I _I	Input current at maximum input voltage	V _{CC} = MAX, V _I = 5.5 V			1			mA
I _{IH}	High-level input current	V _{CC} = MAX, V _I = 2.4 V			40			µA
I _{IL}	Low-level input current	V _{CC} = MAX, V _I = 0.4 V			-1.6			mA
I _{OS}	Short-circuit output current‡	V _{CC} = MAX			-20 -65			mA
I _{CC}	Supply current	V _{CC} = MAX, See Note 2			65 89			mA

† For conditions shown as MIN or MAX, use the appropriate value specified under recommended operating conditions for the applicable type.

‡ All typical values are at V_{CC} = 5 V, T_A = 25°C.

§ Not more than one output should be shorted at a time.

NOTE 2: I_{CC} is measured with all outputs open, clear and load inputs grounded, and all other inputs at 4.5 V.

switching characteristics, V_{CC} = 5 V, T_A = 25°C

PARAMETER¶	FROM INPUT	TO OUTPUT	TEST CONDITIONS	MIN	TYP	MAX	UNIT
f _{max}			C _L = 15 pF, R _L = 400 Ω, See Figures 1 and 2	25	32		MHz
t _{PLH}	UP	\overline{CO}		17	26		ns
t _{PHL}				16	24		ns
t _{PLH}	DOWN	\overline{BO}		16	24		ns
t _{PHL}				16	24		ns
t _{PLH}	UP OR DOWN	Q		25	38		ns
t _{PHL}				31	47		ns
t _{PLH}	LOAD	Q		27	40		ns
t _{PHL}				29	40		ns
t _{PHL}	CLR	Q		22	35		ns

¶ f_{max} - maximum clock frequency

t_{PLH} - propagation delay time, low to high-level output

t_{PHL} - propagation delay time, high to low level output

TYPES SN74LS193, SN54LS193
SYNCHRONOUS 4-BIT UP/DOWN COUNTERS (DUAL CLOCK WITH CLEAR)

recommended operating conditions

		SN54LS193			SN74LS193			UNIT
		MIN	NOM	MAX	MIN	NOM	MAX	
V _{CC}	Supply voltage	4.5	5	5.5	4.75	5	5.25	V
I _{OH}	High-level output current				-400			μA
I _{OL}	Low-level output current				4			8 mA
f _{clock}	Clock frequency	0		25	0		25	MHz
t _w	Width of any input pulse	20			20			ns
t _{su}	Clear inactive-state setup time	15			15			ns
	Load inactive-state setup time	15			15			ns
	Data setup time (see Figure 1)	20			20			ns
t _h	Data hold time	5			5			ns
T _A	Operating free-air temperature range	-55		125	0		70	°C

electrical characteristics over recommended operating free-air temperature range (unless otherwise noted)

PARAMETER	TEST CONDITIONS†	SN54LS193			SN74LS193			UNIT
		MIN	TYP‡	MAX	MIN	TYP‡	MAX	
V _{IH}	High-level input voltage	2			2			V
V _{IL}	Low-level input voltage	0.7			0.8			V
V _{IK}	Input clamp voltage	-1.5			-1.5			V
V _{OH}	High-level output voltage	2.5 3.4			2.7 3.4			V
V _{OL}	Low-level output voltage	0.25 0.4			0.15 0.4			V
I _I	Input current at maximum input voltage	0.1			0.1			mA
I _{IH}	High-level input current	20			20			μA
I _{IL}	Low-level input current	-0.4			-0.4			mA
I _{OS}	Short-circuit output current§	-20 -100			-20 -100			mA
I _{CC}	Supply current	19 34			19 34			mA

† For conditions shown as MIN or MAX, use the appropriate value specified under recommended operating conditions for the applicable type.

‡ All typical values are at V_{CC} = 5 V, T_A = 25°C.

§ Not more than one output should be shorted at a time, and duration of the short-circuit should not exceed one second.

NOTE 2: I_{CC} is measured with all outputs open, clear and load inputs grounded, and all other inputs at 4.5 V.

switching characteristics, V_{CC} = 5 V, T_A = 25°C

PARAMETER	FROM INPUT	TO OUTPUT	TEST CONDITIONS	MIN	TYP	MAX	UNIT
f _{max}			C _L = 15 pF, R _L = 2 kΩ, See Figures 1 and 2	25	32		MHz
t _{PLH}	UP	00		17	26		ns
t _{PHL}				18	24		
t _{PLH}	DOWN	00		16	24		ns
t _{PHL}				15	24		
t _{PLH}	UP OR DOWN	Q		27	38		ns
t _{PHL}				30	47		
t _{PLH}	LOAD	Q		24	40		ns
t _{PHL}				25	40		
t _{PHL}	CLR	Q		23	35		ns

**TYPES SN74193, SN74LS193
SN54193, SN54LS193
SYNCHRONOUS 4-BIT UP/DOWN COUNTERS (DUAL CLOCK WITH CLEAR)**

PARAMETER MEASUREMENT INFORMATION

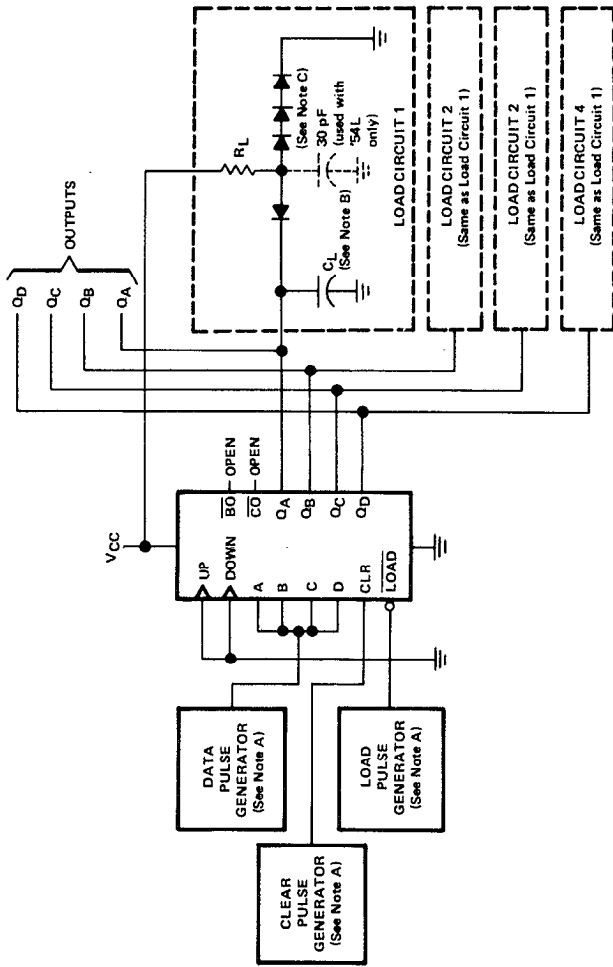

TEST CIRCUIT

- NOTES: A. The pulse generators have the following characteristics: $Z_{out} \approx 50 \Omega$ and for the data pulse generator PRR ≤ 500 kHz, duty cycle = 50%; for the load pulse generator PRR is two times data PRR, duty cycle = 50%.
 B. C_L includes probe and jig capacitance.
 C. Diodes are 1N3064 or equivalent.
 D. t_r and $t_f \leq 7$ ns.
 E. V_{ref} is 1.5 volts for '193, 1.3 V for 'LS193.

FIGURE 1A - CLEAR, SETUP AND LOAD TIMES

TYPES SN74193, SN74LS193
 SN54193, SN54LS193
 SYNCHRONOUS 4-BIT UP/DOWN COUNTERS (DUAL CLOCK WITH CLEAR)

PARAMETER MEASUREMENT INFORMATION

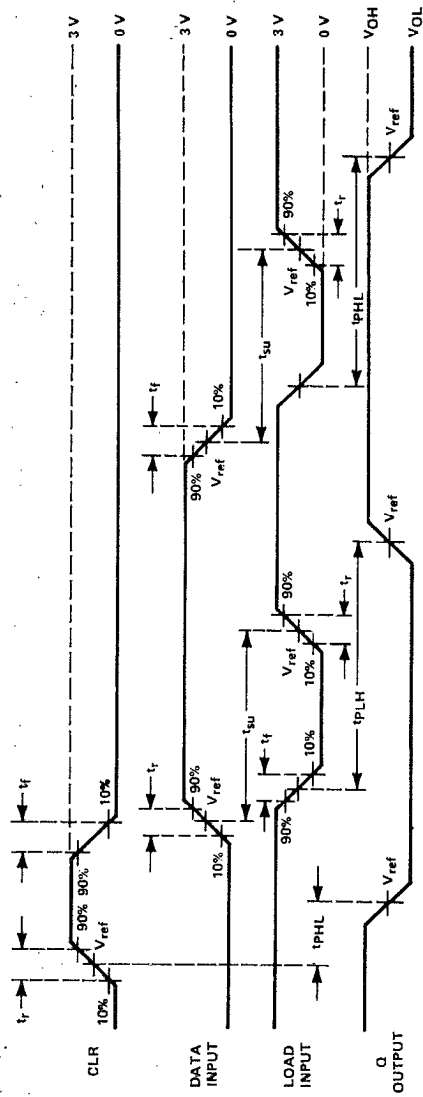

VOLTAGE WAVEFORMS

- NOTES: A. The pulse generators have the following characteristics: $Z_{out} \approx 50 \Omega$ and for the data pulse generator PRR ≤ 500 kHz, duty cycle = 50%; for the load pulse generator PRR is two times data PRR, duty cycle = 50%.
 B. C_L includes probe and jig capacitance.
 C. Diodes are 1N3064 or equivalent.
 D. t_r and $t_f \leq 7$ ns.
 E. V_{ref} is 1.5 volts for '183, 1.3 V for 'LS183.

FIGURE 1B - CLEAR, SETUP, AND LOAD TIMES

TYPES SN74193, SN74LS193
SN54193, SN54LS193
SYNCHRONOUS 4-BIT UP/DOWN COUNTERS (DUAL CLOCK WITH CLEAR)

PARAMETER MEASUREMENT INFORMATION

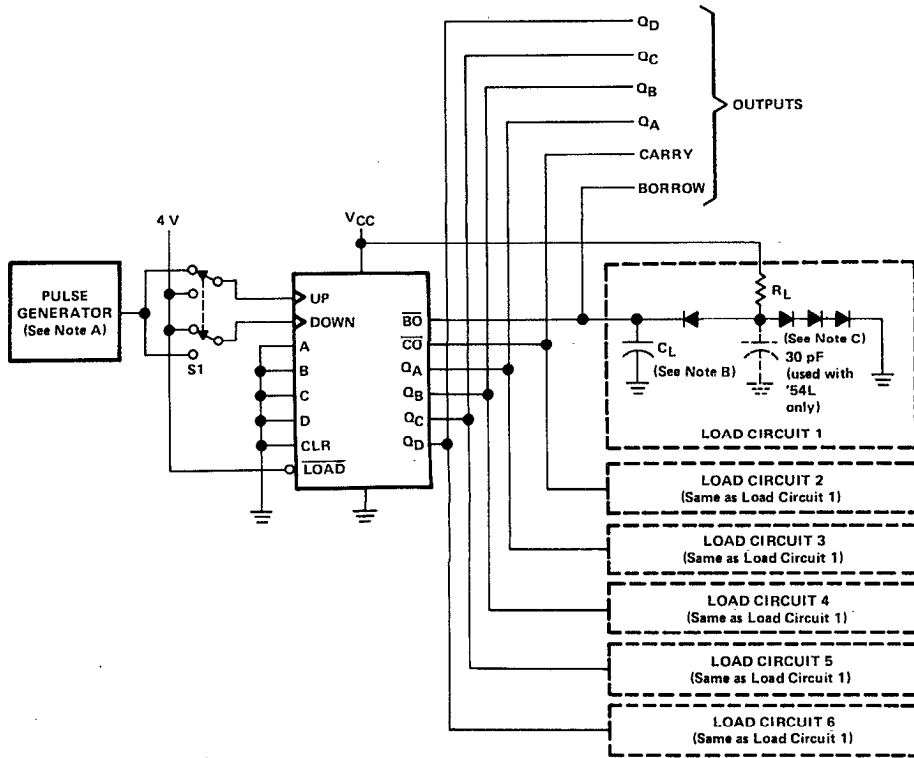

TEST CIRCUIT

- NOTES:
- A. The pulse generator has the following characteristics: $PRR \leq 1 \text{ MHz}$, $Z_{out} \approx 50 \Omega$, duty cycle = 50%.
 - B. C_L includes probe and jig capacitance.
 - C. Diodes are 1N3064 or equivalent.
 - D. Count-up and count-down pulse shown are for the '193, and 'LS193 binary counters.
 - E. Waveforms for outputs Q_A , Q_B , and Q_C are omitted to simplify the drawing.
 - F. t_r and $t_f \leq 7 \text{ ns}$.
 - G. V_{ref} is 1.5 volts for '193, 1.3 V for 'LS193.

FIGURE 2A – PROPAGATION DELAY TIMES

TYPES SN74193, SN74LS193
 SN54193, SN54LS193
 SYNCHRONOUS 4-BIT UP/DOWN COUNTERS (DUAL CLOCK WITH CLEAR)

PARAMETER MEASUREMENT INFORMATION

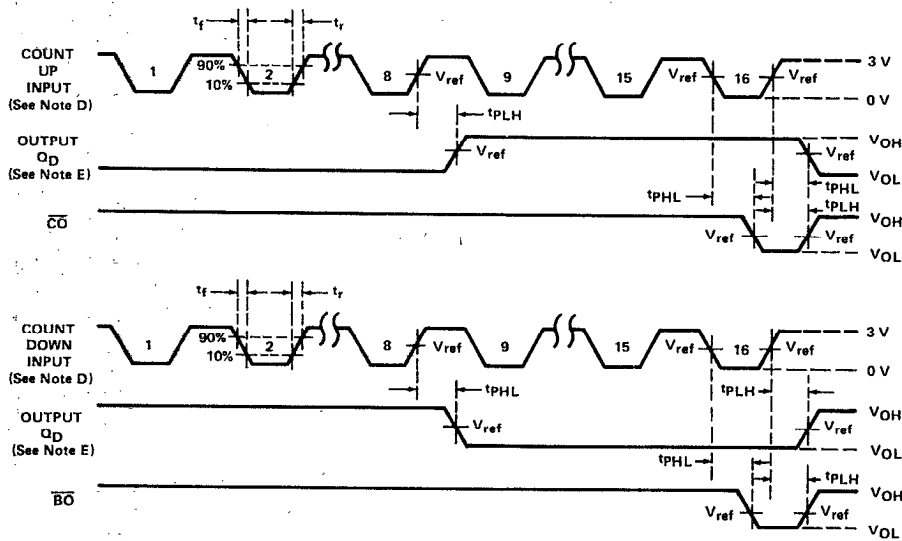

VOLTAGE WAVEFORMS

- NOTES:
- A. The pulse generator has the following characteristics: PRR < 1 MHz, $Z_{out} \approx 50 \Omega$, duty cycle = 50%.
 - B. C_L includes probe and jig capacitance.
 - C. Diodes are 1N3064 or equivalent.
 - D. Count-up and count-down pulse shown are for the '193, and 'LS193 binary counters.
 - E. Waveforms for outputs Q_A , Q_B , and Q_C are omitted to simplify the drawing.
 - F. t_r and $t_f \leq 7$ ns.
 - G. V_{ref} is 1.5 volts for '193, 1.3 V for 'LS193.

FIGURE 2B - PROPAGATION DELAY TIMES