

REV. 更改	DESCRIPTION 說明	ENG. 修改人	APPROVE 審核
------------	-------------------	-------------	---------------

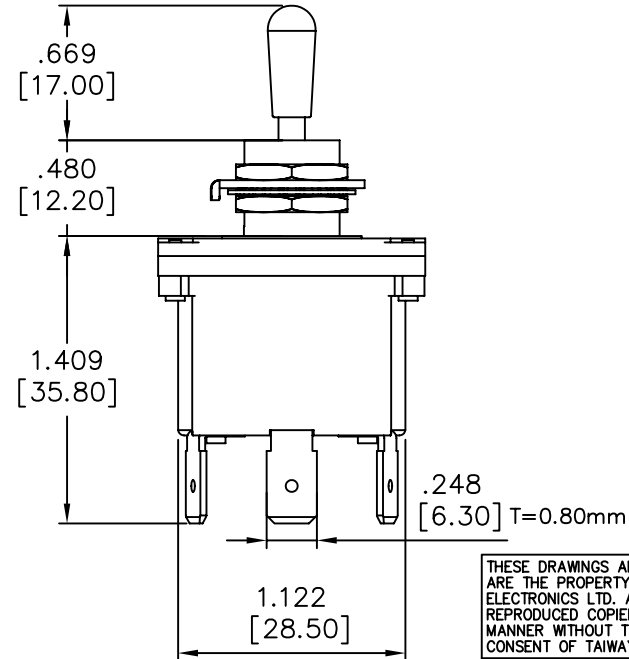
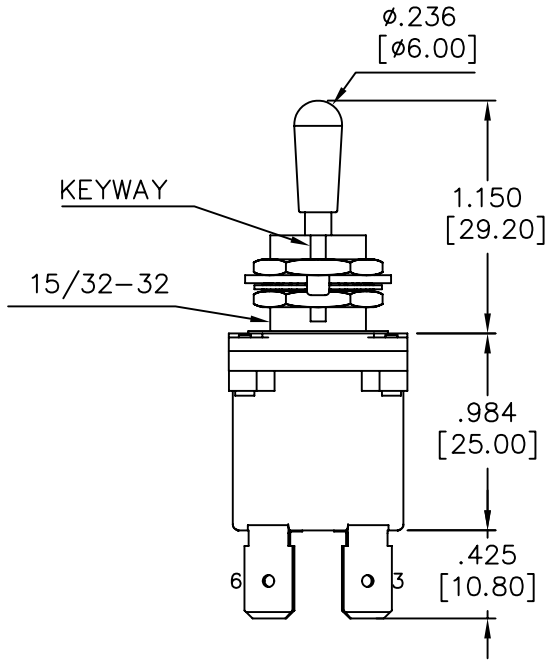
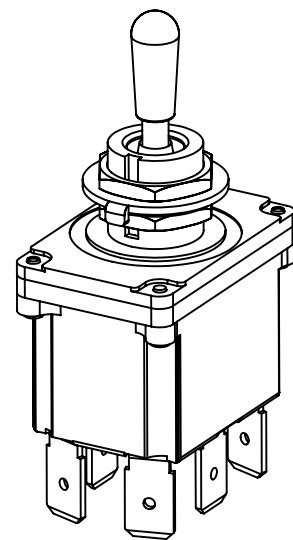
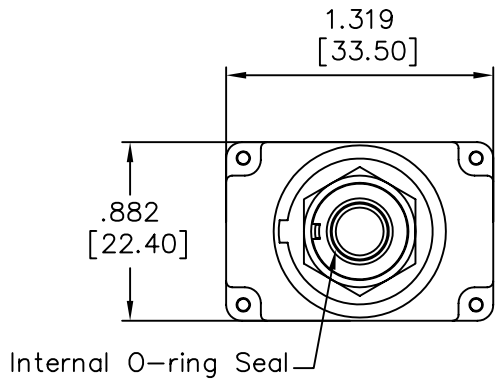
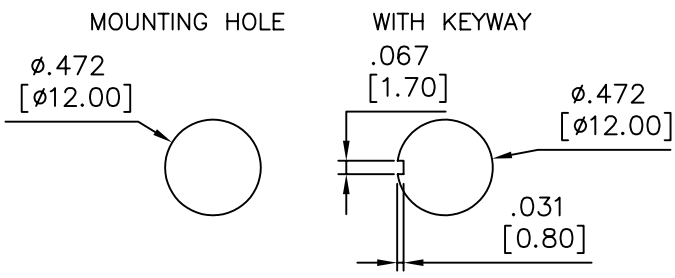

MODEL NO.	SWITCH POSITION		
DP-1	ON	NONE	ON
DP-2	ON	NONE	(ON)
DP-A	(ON)	NONE	ON
DP-3	ON	OFF	ON
DP-4	(ON)	OFF	(ON)
DP-5	ON	OFF	(ON)
Term. Comm.	2-3	OPEN	2-1
	5-6		5-4

**SPECIFICATIONS:**

- MOVABLE CONTACT: Copper alloy, silver plated
- TERMINALS: Brass bronzing
- RATING: 10A @ 250VAC or 12A @ 125VAC  
1/2 HP 125VAC/ 1HP 250VAC/5A 125VAC
- CONTACT RESISTANCE: 20m-ohms max. initial
- INSULATION RESISTANCE: 100M-ohms min. @ 500VDC
- DIELECTRIC STRENGTH: 1,500V RMS @ sea level
- ELECTRICAL LIFE: 30,000 make and break cycles at full load
- OPERATING TEMPERATURE: -30°C to +85°C
- IP67 Protection Class
- HAND SOLDERING TEMPERATURE: 350°C for 3sec. Max.  
(No pressure to be applied on terminals)

THESE DRAWINGS AND SPECIFICATIONS ARE THE PROPERTY OF TAIWAY ELECTRONICS LTD. AND SHALL NOT BE REPRODUCED COPIED OR USED IN ANY MANNER WITHOUT THE PRIOR WRITTEN CONSENT OF TAIWAY ELECTRONICS LTD.

UNLESS OTHERWISE SPECIFIED DIMENSIONS ARE IN MILLIMETERS ANGULAR TOLERANCE: ±1.0°

DIMENSIONS	TOLERANCE
0.00 TO 30.00mm	±0.20mm
30.01 TO 80.00mm	±0.25mm
80.01 TO 150.00mm	±0.30mm
150.01	±0.40mm

泰瑋電子有限公司  
TAIWAY ELECTRONICS COMPONENTS CO.,LTD.

USED 用途	L7A	APPD. 審核	Amy 2010/02/08
FINISH 處理		CHKD. 校對	Amy 2010/02/08
SCALE 比例	/	UNIT 單位	in(mm)
DR. 製圖		Amy 2010/02/08	
TITLE 名稱		SEALED TOGGLE SWITCH	
DWG NO. 圖號		L7A-DP4-A10B0M3X	
FILE NAME 檔案名稱		SHEET 張	1/1
REV. 更改		1	