

TO : \_\_\_\_\_

DATE : 2003. . . .

# SPECIFICATION

PRODUCT : STARCAP  
\_\_\_\_\_

MODEL : DC SERIES  
\_\_\_\_\_

WRITTEN	CHECKED	APPROVED

KORCHIP Corporation

219-8, GASANDONG, GUMCHUN-GU, SEOUL, KOREA

TEL : 82 - 2 - 838 - 5588

FAX : 82 - 2 - 859 - 5858

# S P E C I F I C A S I O N

## STARCAP(ELECTRIC DOUBLE LAYER CAPACITOR)

### 1. SCOPE

THESE ARE THE SPECIFICATIONS OF STARCAP(ELECTRIC DOUBLE LAYER CAPACITOR) WHICH YOU ARE USING.

PLEASE STUDY THESE APPLICATIONS AND APPROVED THEM.

### 2. PART NUMBER SYSTEM

SC DC 5R5 474 V

STARCAP

SERIES NAME

RATED VOLTAGE : 5.5Vdc

CAPACITANCE : 474 - 0.47F, 105 - 1.0F

LEAD TYPE : V - VERTICAL BULK

H - HORIZONTAL BULK

C - CASE INSERT TYPE

### 3. CHARACTERISTICS

OPERATING TEMPERATURE	-25 ~ +70
RATED VOLTAGE	5.5 VDC
CAPACITANCE TOLERANCE	-20 ~ 80 %
EQUIVALENT SERIES RESISTANCE	0.22F : LESS THAN 75 0.33F : LESS THAN 50 0.47F : LESS THAN 60 1.0 F : LESS THAN 30
LEAKAGE CURRENT	0.22F : LESS THAN 330 $\mu$ A 0.33F : LESS THAN 500 $\mu$ A 0.47F : LESS THAN 710 $\mu$ A 1.0 F : LESS THAN 1500 $\mu$ A

### 4. MARKING

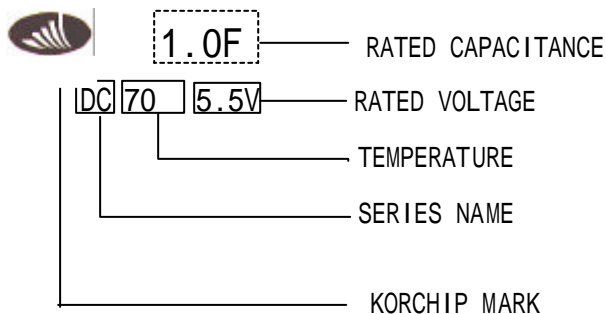

## 5. CONSTRUCTION AND DIMENSION

ITEMS	CAPACITANCE (F)	CAP TOL (%)	ESR ( )	LEAKAGE CURRENT (mA)
SCDC5R5224	0.22	-20 ~ +80%	75 MAX	0.33 MAX
SCDC5R5334	0.33	-20 ~ +80%	50 MAX	0.50 MAX
SCDC5R5474	0.47	-20 ~ +80%	60 MAX	0.71 MAX
SCDC5R5105	1.0	-20 ~ +80%	30 MAX	1.50 MAX

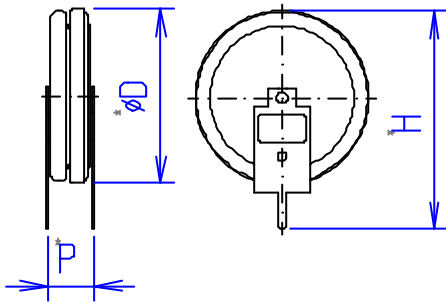

NO	ITEM	RATED VOLT	CAP	SIZE (mm)		
				D	H	P
1	SCDC5R5224V	5.5VDC	0.22F	11.5	16.0	5.0
2	SCDC5R5334V	5.5VDC	0.33F	11.5	16.0	5.0
3	SCDC5R5474V	5.5VDC	0.47F	19.0	23.5	5.0
4	SCDC5R5105V	5.5VDC	1.0F	19.0	23.5	5.0

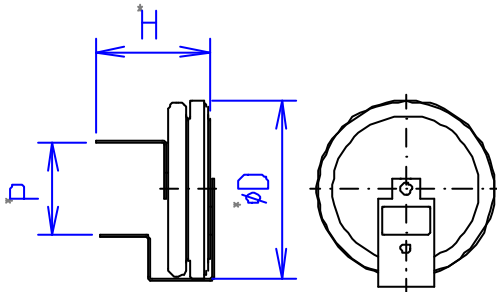

NO	ITEM	RATED VOLT	CAP	SIZE (mm)		
				D	H	P
1	SCDC5R5224H	5.5VDC	0.22F	11.5	10.5	10.0
2	SCDC5R5334H	5.5VDC	0.33F	11.5	10.5	10.0
3	SCDC5R5474H	5.5VDC	0.47F	19.0	10.5	20.0
4	SCDC5R5105H	5.5VDC	1.0F	19.0	10.5	20.0

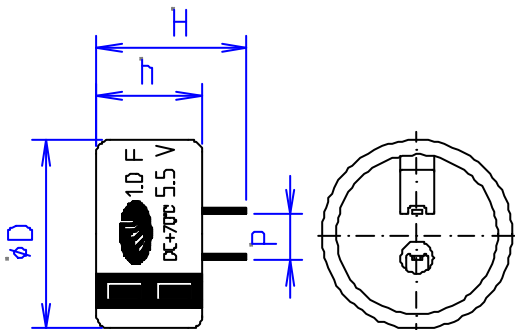

NO	ITEM	RATED VOLT	CAP	SIZE (mm)		
				D	H	P
1	SCDC5R5224C	5.5VDC	0.22F	13.5	13.5	5.0
2	SCDC5R5334C	5.5VDC	0.33F	13.5	13.5	5.0
3	SCDC5R5474C	5.5VDC	0.47F	21.5	13.5	5.0
4	SCDC5R5105C	5.5VDC	1.0F	21.5	13.5	5.0

6. SPECIFICATIONS AND TEST METHOD

ITEM		SPECIFICATION		TEST CONDITION													
OPERATING TEMP. RANGE		-25 ~ +70															
RATED VOLTAGE		5.5VDC															
CAPACITANCE		0.22F ~ 1.0F		TO SEE MEASURE METHOD													
CAPACITANCE TOLERANCE		+80% , -20%		TO SEE MEASURE METHOD													
EQUIV. SERIES. RES.(ESR)		TO SEE CONSTRUCTION&DIM.		FRE. :1kHz, 1mA ,													
LEAKAGE CURRENT(30 MIN)		TO SEE CONSTRUCTION&DIM.		VOLT:5V, TO SEE MEASURE METHOD RES. :0.022F ~ 0.047F 1000 0.1F ~ 0.47F 100 1.0F 10													
SURGE VOLTAGE	CAPACITANCE	MORE THAN90% SPEC. VALUE		TEMP:70 ± 2 , VOLT:6.3V CH. :30SEC, DISCH:5MIN30SEC CYCLE:1000CYCLE RESISTANCE: 0.022F:560 , 0.047F:300 0.1F:150 , 0.22F:56 0.33F:40 , 0.47F:30 , 1.0F:15 DISCHARGE RESISTANCE:0													
	ESR	LESS THAN 1.2TIMES SPECIFICATION VALUE															
	LC(30 MIN)																
	APPEARANCE	NO MARKED DEFECT															
TEMPERATURE CHARACTERISTICS	CAPACITANCE	STAGE	50% OF INI. VAL	<table border="1"> <thead> <tr> <th>STAGE</th> <th>TEMPERATURE</th> </tr> </thead> <tbody> <tr> <td>1</td> <td>20 ± 2</td> </tr> <tr> <td>2</td> <td>-25 ± 2</td> </tr> <tr> <td>3</td> <td>20 ± 2</td> </tr> <tr> <td>4</td> <td>70 ± 2</td> </tr> <tr> <td>5</td> <td>20 ± 2</td> </tr> </tbody> </table>		STAGE	TEMPERATURE	1	20 ± 2	2	-25 ± 2	3	20 ± 2	4	70 ± 2	5	20 ± 2
	STAGE	TEMPERATURE															
	1	20 ± 2															
	2	-25 ± 2															
	3	20 ± 2															
	4	70 ± 2															
	5	20 ± 2															
	ESR	2	3TIMES OF INI. V														
CAPACITANCE	STAGE	150% OF INI. VAL															
ESR		SPEC. VALUE															
LC(30 MIN)	4	1.5CV(mA)															
CAPACITANCE	STAGE	WITHIN ± 30% INI V															
ESR		SPEC. VALUE															
LC(30MIN)		SPEC. VALUE															
LEAD STRENGTH		LEAD TERMINAL SHALL NOT BE SEPARATED		LOAD 1kg , 10 ± 1SEC													
LEAD BEND STRENGTH				LOAD:1kg ANGLE 90 ° , 1 CYCLE													
VIBRATION RESISTANCE	CAPACITANCE	SPEC. VALUE		AMPLITUDE: 1.5mm													
	ESR	SPEC. VALUE		FREQUENCY: 10 ~ 55Hz													
	LC(30MIN)	SPEC. VALUE		DIRECTION:X,Y,Z 3 DIRECTIONS													
	APPEARANCE	NO MARKED DEFECT		TEST TIME:6HOURS													
SOLDER ABILITY		TERMINAL SHALL BE SOLDERED OVER THAN 3/4		SOLDER TEMP:230 ± 5 IMMERSION TIME:5 ± 0.5SEC DIP LENGTH:TO 1.6mm FROM THE BOTTOM OF BODY													
SOLDERING EFFECT	CAPACITANCE	SPEC. VALUE		SOLDER TEMP:260 ± 5													
	ESR	SPEC. VALUE		IMMERSION TIME:10 ± 1SEC													
	LC(30MIN)	SPEC. VALUE		DIP LENGTH:TO 1.6mm FROM THE BOTTOM OF BODY													
	APPEARANCE	NO MARKED DEFECT															

ITEM		SPECIFICATION	TEST CONDITION	
TEMP. CYCLE	CAPACITANCE	SPEC. VALUE	TEMP: -25 20 70 20 CYCLE: 5CYCLE	
	ESR	SPEC. VALUE		
	LC(30MIN)	SPEC. VALUE		
	APPEARANCE	NO MARKED DEFECT		
HUMIDITY	CAPACITANCE	90% OF SPEC. VAL	TEMP: 40 ± 2 HUMIDITY: 90 ~ 95%RH TEST TIME: 240 ± 8HOURS	
	ESR	1.2TIMES OF SPE. V		
	LC(30MIN)	1.2TIMES OF SPE. V		
	APPEARANCE	NO MARKED DEFECT		
HIGH TEMP. LOADING	CAPACITANCE	70% OF SPEC. VAL	TEMP: 70 ± 2 VOLT: WORKING VOLTAGE RESISTANCE: 0 TEST TIME: 1,000 (+48, -0)HOURS	
	ESR	3TIMES OF SPE. V		
	LC(30MIN)	3TIMES OF SPE. V		
	APPEARANCE	NO MARKED DEFECT		
SELF DISCHARGE CHARACTERISTICS		MORE THAN 4.2V	CHARGING CONDITION	VOLTAGE: 5.0V RESISTANCE: 0 CHARGE TIME: 24HOURS
			NEGLIGENCE CONDITION	24HOURS NEGLIGENCE IN OPEN STATE TEMP: LESS THAN 25 HUMIDITY: LESS THAN 70%RH

## 7. PACKING WAY

PRODUCT		QUANTITY(PCS)			SIZE(WxHxT)		WEIGHT
		VINYL BAG ( ) /TRAY ( )	INNER BOX	OUTER BOX	INNER BOX (mm)	OUTER BOX (mm)	
5.5V 0.22F	BULK	500	2,000	4,000	240*220*95	460*260*130	7KG
5.5V 0.33F	BULK	500	2,000	4,000	240*220*95	460*260*130	7KG
5.5V 0.47F	BULK[V]	100	500	2,000	310*310*110	640*330*250	12KG
	BULK[C]						22KG
5.5V 1.0F	BULK[V]	100	500	2,000	310*310*110	640*330*250	12KG
	BULK[C]						22KG

8. MEASURING METHOD OF CHARACTERISTICS

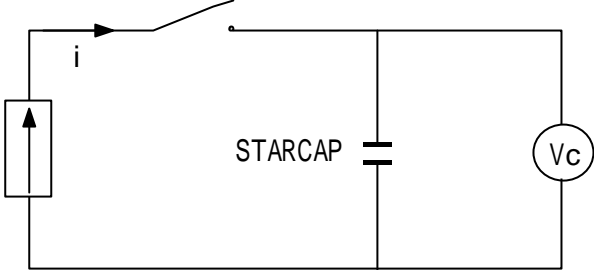
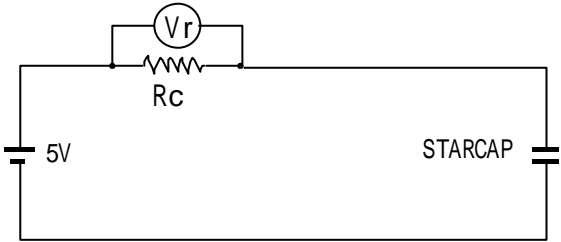
<p>CAPACITANCE</p>	<p>1) CHARGE THE STARCAP WITH <math>10 \pm 0.1\text{mA}</math>.</p> <p>2) READ THE TIME TAKEN FOR THE VOLTAGE TO RISE FROM <math>2 \pm 0.05\text{V}</math> TO <math>4 \pm 0.05\text{V}</math>. THE TIME MEASURED IS INDICATED BY "T".</p> <p>3) CALCULATE CAPACITANCE USING THE FOLLOWING FORMULA.</p> $C = (i/T) / V_c$ <p style="text-align: right;">i : A T : SECOND V<sub>c</sub> ; VOLTAGE (2V = 4V-2V)</p> 
<p>EQUIVALENT SERIES RESISTANCE</p>	<p>MEASURE ESR BY THE LCR METER.</p> <p>FREQUENCY : 1kHz</p> <p>BIAS VOLTAGE : 0V</p>
<p>LEAKAGE CURRENT</p>	<p>1) APPLY <math>5 \pm 0.1\text{V}</math> TO THE STARCAP.</p> <p>2) MEASURE <math>V_r</math> AFTER <math>30 \pm 0.5</math> MIN.</p> <p>3) CALCULATE CURRENT USING THE FOLLOWING FORMULA.</p> $LC \text{ (AT 30 MINUTES)} = V_r / R_c \text{ (A)} \quad R_c = 10 \pm 0.1 \text{ ( )}$ 
<p>THE STARCAP SHOULD BE SHORTED BEFORE EACH MEASUREMENT AS FOLLOWS ;</p> <p>CAPACITANCE : 60 MIN., ESR: 15 MIN., L C : 15 MIN.</p>	

## 9. CAUTION FOR USE

PLEASE BE CAREFUL FOLLOWING POINTS WHEN YOU USE STARCAP.

### 1) DON'T APPLY MORE THAN RATED VOLTAGE.

IF YOU APPLY MORE THAN RATED VOLTAGE, STARCAP'S ELECTROLYTE IS ELECTROLYZED. AND ITS ESR GETS HIGHER. AT THE WORST, IT IS BROKEN.

### 2) DON'T USE FOR RIPPLE ABSORPTION.

### 3) POLARITY

THE STARCAP IS NON-POLAR FUNDAMENTALLY. HOWEVER STARCAP IS MADE POLARITY, WHEN IT IS PACKED.

PLEASE MOUNT IT IN ACCORDANCE WITH ITS POLARITY FOR THE MAINTAINING BEST CONDITION.

### 4) OPERATING TEMPERATURE AND LIFE

GENERALLY SPEAKING, STARCAP HAS A LOWER LEAKAGE CURRENT, LONGER BACK-UP TIME AND LONGER LIFE IN THE LOW TEMP.

BUT, IT HAS A HIGHER LEAKAGE CURRENT, SHORTER BACK-UP TIME AND SHORTER LIFE IN THE HIGH TEMP.

PLEASE DESIGN TO KEEP STARCAP AWAY A CALORIFIC PARTS.

### 5) CLEANING

STARCAP IS A PROOF AGAINST CLEANING. CLEANING GUARANTEE IS AS FOLLOWS ;

SOLVENT : FREON TES45

ULTRASONIC WAVE : LESS THAN 38kHz, LESS THAN 20 Watt/Liter.

IMMERSING TIME : LESS THAN 10 MIN.

ULTRASONIC WAVE MUST NOT BE CENTERED.

### 6) SOLDERING

WHEN YOU SOLDER BY SOLDER IRON, PLEASE DO QUICKLY IT WITHIN 3SEC.

PLEASE DON'T TOUCH THE RESIN CASE OF STARCAP BY SOLDER IRON.

BECAUSE THE RESIN MAY BE MELTED BY ITS HEAT.

### 7) FOLLOWING FIGURE SHOWS THE GENERAL BACK-UP CIRCUIT.

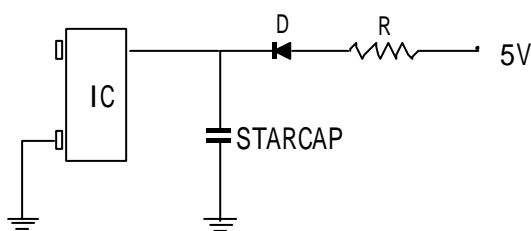

D: DIODE FOR PROTECTION OF COUNTER  
R: RESISTOR FOR PROTECTION OF  
ELECTRIC POWER SOURCE

8) SHORT CIRCUIT STARCAP

YOU CAN SHORT-CIRCUIT BETWEEN TERMINALS WITHOUT RESISTER.

HOWEVER WHEN YOU SHORT CIRCUIT FREQUENTLY, PLEASE LET US KNOW.

WE THINK THAT FREQUENTLY CONDITION IS AS FOLLOWS ;

CHARGE : 30 SEC., DISCHARGE : 30 SEC., CYCLE : 1000 CYCLE, TEMP. : 70

9) STORAGE

PLEASE STORE STARCAP IN FOLLOWING CONDITION ;

TEMP. : 15 ~ 35 , HUMIDITY : 45 ~ 75%RH, NON-DUST

10) PLEASE DON'T DISASSEMBLE STARCAP. BECAUSE ITS ELECTROLYTE IS SULFURIC ACID.  
IT'S DANGEROUS TO MANKIND.

11) WHEN YOU USE BOND CURE SKIN, PLEASE CONTACT US FOR ITS CONDITION.

12) SERIES CONNECTION OF STARCAP CAUSES A DIFFERENCE OF APPLIED VOLTAGE  
FOR EACH STARCAP, BECAUSE OF DISPERSION OF CAPACITANCE AND ESR.  
AS A RESULT, IT'S POSSIBLE TO APPLY OVER-RATED VOLTAGE.  
PLEASE INFORM US IF YOU ARE USING STARCAP IN SERIES CONNECTION.  
AND PLEASE DESIGN SO AS NOT TO APPLY OVER-RATED VOLTAGE TO EACH STARCAP,  
AND USE STARCAPS IN SAME LOT.