

## Type 2 surge protection plug - F-MS 12 ST - 2817990

Please be informed that the data shown in this PDF Document is generated from our Online Catalog. Please find the complete data in the user's documentation. Our General Terms of Use for Downloads are valid (<http://phoenixcontact.com/download>)



Surge protection plug type 2, with N-PE total current spark gap for base element.



### Key commercial data

Packing unit	10 pc
GTIN	 4 017918 163648
Weight per Piece (excluding packing)	35.56 g
Custom tariff number	85363010
Country of origin	Germany

### Technical data

#### Dimensions

Height	52.4 mm
Width	17.5 mm
Depth	55.3 mm
Horizontal pitch	1 Div.

#### Ambient conditions

Degree of protection	IP20
Ambient temperature (operation)	-40 °C ... 80 °C
Ambient temperature (storage/transport)	-40 °C ... 80 °C
Altitude	≤ 2000 m (amsl (above mean sea level))
Permissible humidity (operation)	5 % ... 95 %
Shock (operation)	25g
Vibration (operation)	5g

#### General

Standards/specifications	IEC 61643-11 2011
--------------------------	-------------------

# Type 2 surge protection plug - F-MS 12 ST - 2817990

## Technical data

### General

	EN 61643-11 2012
IEC test classification	II
	T2
EN type	T2
SPD design	Voltage-switching type
Mode of protection	N-PE
Mounting type	On base element
Color	black
Housing material	PA 6.6
Pollution degree	2
Inflammability class according to UL 94	V-0
Type	DIN rail module, two-section, divisible
Number of positions	1
Arrester can be tested with CHECKMASTER from software version:	From SW rev. 1.10
Surge protection fault message	Optical

### Protective circuit

Nominal voltage $U_N$	240/415 V AC (TN - only N-PE)
	240/415 V AC (TT - only N-PE)
Nominal frequency $f_N$	50 Hz (60 Hz)
Maximum continuous operating voltage $U_C$	260 V AC
Residual current $I_{PE}$	$\leq 5 \mu A$
Standby power consumption $P_C$	$\leq 1.5 \text{ mVA}$
Nominal discharge current $I_n$ (8/20) $\mu s$	20 kA
Maximum discharge current $I_{max}$ (8/20) $\mu s$	40 kA
Follow current interrupt rating $I_{fi}$	100 A (260 V)
Voltage protection level $U_p$	$\leq 1.5 \text{ kV}$
Residual voltage $U_{res}$	$\leq 0.4 \text{ kV}$ (at $I_n$ )
	$\leq 0.25 \text{ kV}$ (at 10 kA)
	$\leq 0.15 \text{ kV}$ (at 5 kA)
	$\leq 0.1 \text{ kV}$ (at 3 kA)
Front of wave sparkover voltage at 6 kV (1.2/50) $\mu s$	$\leq 1.5 \text{ kV}$
TOV behavior at $U_T$	1200 V AC (200 ms / withstand mode)
Response time $t_A$	$\leq 100 \text{ ns}$

### Connection data

Connection method	VALVETRAB plug-in system
-------------------	--------------------------

### UL specifications

UL class	Type 4 SPD for Type 2 applications
Maximum continuous operating voltage MCOV (N-G)	260 V AC
Mode of protection	N-G

# Type 2 surge protection plug - F-MS 12 ST - 2817990

## Technical data

### UL specifications

Power distribution system	1
Voltage protection rating VPR (N-G)	1 kV
Nominal discharge current I <sub>n</sub> (N-G)	20 kA

## Classifications

### eCl@ss

eCl@ss 4.0	27140201
eCl@ss 4.1	27130801
eCl@ss 5.0	27130801
eCl@ss 5.1	27130801
eCl@ss 6.0	27130805
eCl@ss 7.0	27130805
eCl@ss 8.0	27130805

### ETIM

ETIM 2.0	EC000941
ETIM 3.0	EC000941
ETIM 4.0	EC000941
ETIM 5.0	EC000941

### UNSPSC

UNSPSC 6.01	30212010
UNSPSC 7.0901	39121610
UNSPSC 11	39121610
UNSPSC 12.01	39121610
UNSPSC 13.2	39121620

## Approvals

### Approvals

---

#### Approvals

ÖVE / IECCEB Scheme / UL Recognized / KEMA-KEUR / cUL Recognized / GL / CCA / ÖVE / CSA / EAC / cULus Recognized

---

#### Ex Approvals

---

#### Approvals submitted

---

# Type 2 surge protection plug - F-MS 12 ST - 2817990

## Approvals

### Approval details

ÖVE

IECEE CB Scheme

UL Recognized

KEMA-KEUR

cUL Recognized

GL

CCA

ÖVE

CSA

EAC

cULus Recognized

## Accessories

Accessories

Device marking

## Type 2 surge protection plug - F-MS 12 ST - 2817990

### Accessories

Zack marker strip - ZBN 18:UNBEDRUCKT - 2809128



Zack marker strip, Strip, white, unlabeled, can be labeled with: Plotter, Mounting type: Snap into tall marker groove, for terminal block width: 18 mm, Lettering field: 18 x 5 mm

---

### Labeled device marker

Marker for terminal blocks - ZBN 18,LGS:ERDE - 2749589



Marker for terminal blocks, Strip, white, labeled, Horizontal: Grounding symbol, Mounting type: Snap into tall marker groove, for terminal block width: 18 mm, Lettering field: 18 x 5 mm

Marker for terminal blocks - ZBN 18,LGS:L1-N,ERDE - 2749576



Marker for terminal blocks, Strip, white, labeled, Horizontal: L1, L2, L3, N, GND, Mounting type: Snap into tall marker groove, for terminal block width: 18 mm, Lettering field: 18 x 5 mm

---

### Marker pen

Marker pen - B-STIFT - 1051993



Marker pen, for manual labeling of unprinted Zack strips, smear-proof and waterproof, line thickness 0.5 mm

---

### Additional products

Type 2 surge protection device - F-MS 12/FM - 2817974



Surge arrester type 2, consisting of base element with remote indicator contact and protective plug with N-PE total current spark gap for mounting on NS 35/7.5, housing width: 17.5 mm (1 Div.)

## Type 2 surge protection plug - F-MS 12 ST - 2817990

### Accessories

Type 2 surge protection device - F-MS 12 - 2817987



Surge arrester type 2, consisting of base element and protective plug with N-PE total current spark gap for mounting on NS 35/7.5, housing width: 17.5 mm (1 Div.)

Type 2 surge protection base element - VAL-MS BE/FM - 2817738



Base element for type 2 arresters of the VALVETRAB MS series of products, with remote indication contact. Design: 1-channel

Type 2 surge protection base element - VAL-MS BE - 2817741



Base element for type 2 arresters of the VALVETRAB MS series of products. Design: 1-channel

### Drawings

Dimensioned drawing

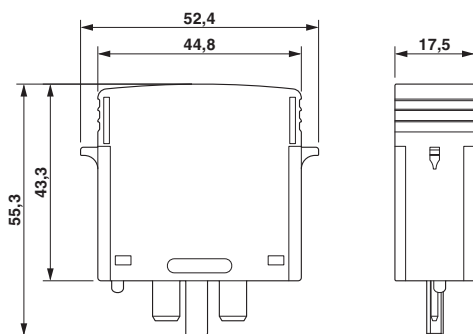

Circuit diagram

