

## Technical Data Sheet

### 1.6×0.8mm Package Infrared LED

#### IR83-01C/TR8

#### Features

- Peak wavelength  $\lambda_p=940\text{nm}$
- Low forward voltage
- Pb free
- The product itself will remain within RoHS compliant version.

#### Descriptions

- IR83-01C/TR8 is an infrared emitting diode in miniature SMD package which is molded in a water clear plastic with top view lens.
- The device is spectrally matched with silicon photodiode and phototransistor.

#### Applications

- Infrared applied system

#### Device Selection Guide

LED Part No.	Chip	Lens Color
	Material	
IR83-01C/TR8	GaAlAs	Water clear

**Package Dimensions**

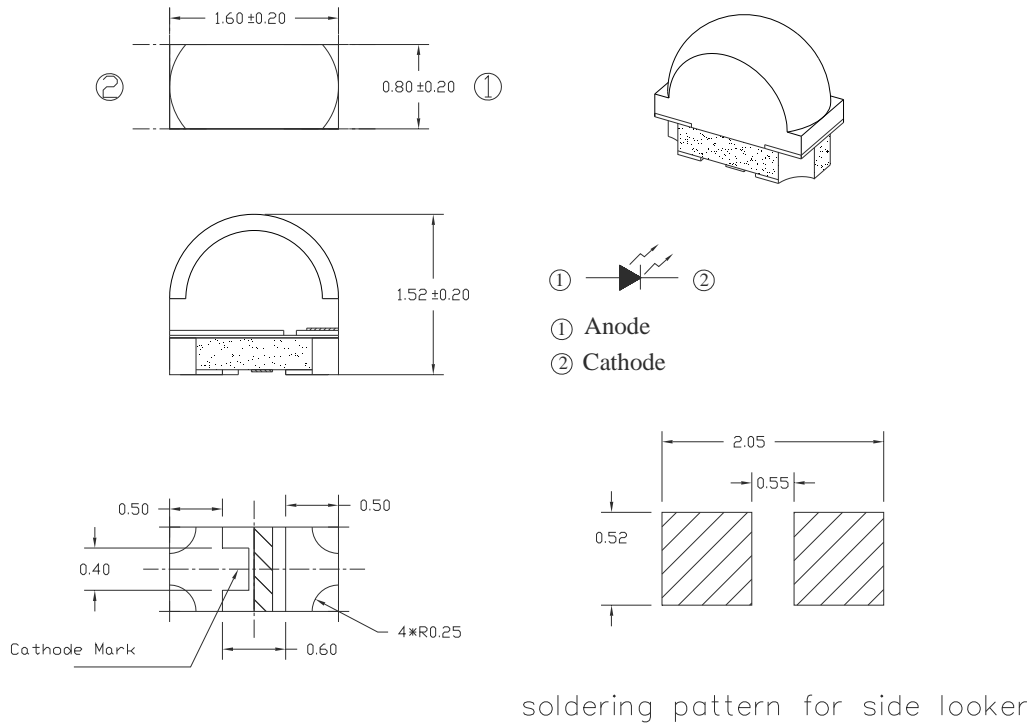

- Notes:** 1.All dimensions are in millimeters  
 2.Tolerances unless dimensions  $\pm 0.1$ mm

**Absolute Maximum Ratings (Ta=25°C)**

Parameter	Symbol	Rating	Units
Continuous Forward Current	I <sub>F</sub>	65	mA
Peak Forward Current *1	I <sub>FP</sub>	1.0	A
Reverse Voltage	V <sub>R</sub>	5	V
Operating Temperature	T <sub>opr</sub>	-40 ~ +85	°C
Storage Temperature	T <sub>stg</sub>	-40 ~ +100	°C
Soldering Temperature *2	T <sub>sol</sub>	260	°C
Power Dissipation at(or below) 25°C Free Air Temperature	P <sub>d</sub>	100	mW

- Notes:** \*1:I<sub>FP</sub> Conditions--Pulse Width  $\leq 100 \mu$  s and Duty  $\leq 1\%$ .  
 \*2:Soldering time  $\leq 5$  seconds.

**Electro-Optical Characteristics (Ta=25°C)**

Parameter	Symbol	Condition	Min.	Typ.	Max.	Units
Radiant Intensity	I <sub>e</sub>	I <sub>F</sub> =20mA	0.2	1.6	--	mW /sr
Peak Wavelength	λ <sub>p</sub>	I <sub>F</sub> =20mA	--	940	--	nm
Spectral Bandwidth	Δ λ	I <sub>F</sub> =20mA	--	45	--	nm
Forward Voltage	V <sub>F</sub>	I <sub>F</sub> =20mA	--	1.2	1.5	V
Reverse Current	I <sub>R</sub>	V <sub>R</sub> =5V	--	--	10	μ A
View Angle	2 θ 1/2	I <sub>F</sub> =20mA (X)	--	115	--	deg
		I <sub>F</sub> =20mA (Y)	--	55	--	

**Typical Electro-Optical Characteristics Curves**

Fig.1 Forward Current vs. Ambient Temperature

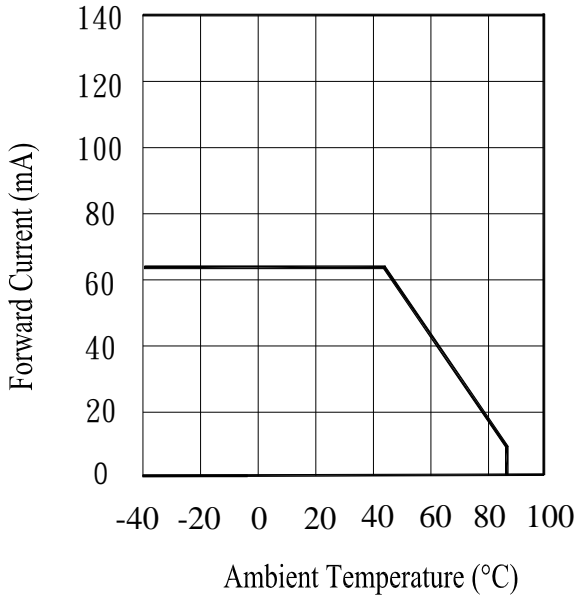

Fig.2 Spectral Distribution

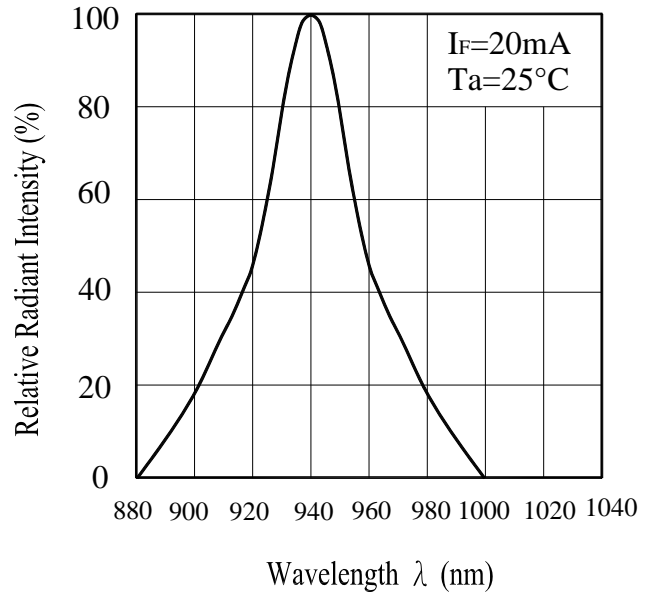

Fig.3 Radiant Intensity vs Forward Current

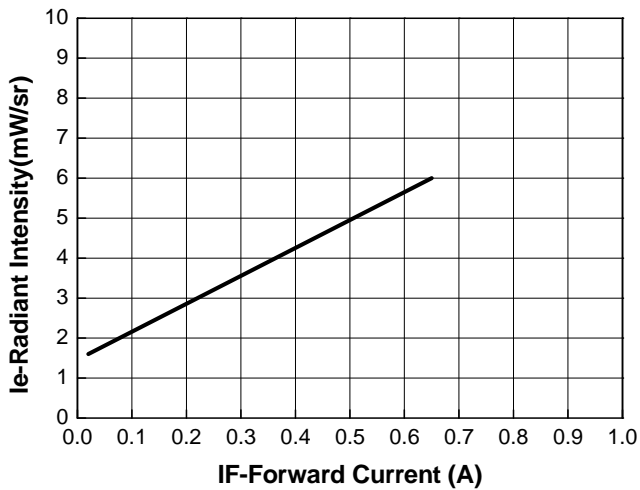
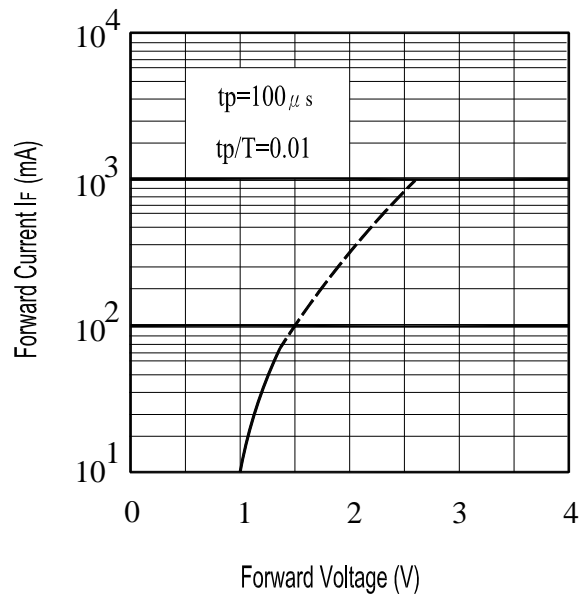

Fig.4 Forward Current vs. Forward Voltage



**Typical Electro-Optical Characteristics Curves**

Fig.5 Relative Radiant Intensity vs.

Angular Displacement

(X axle)

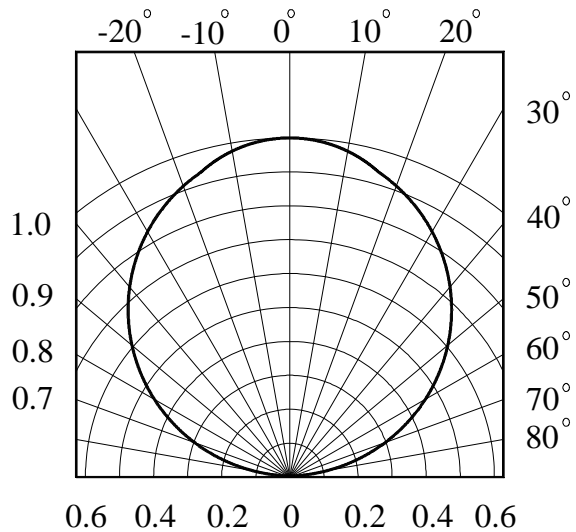

(Y axle)

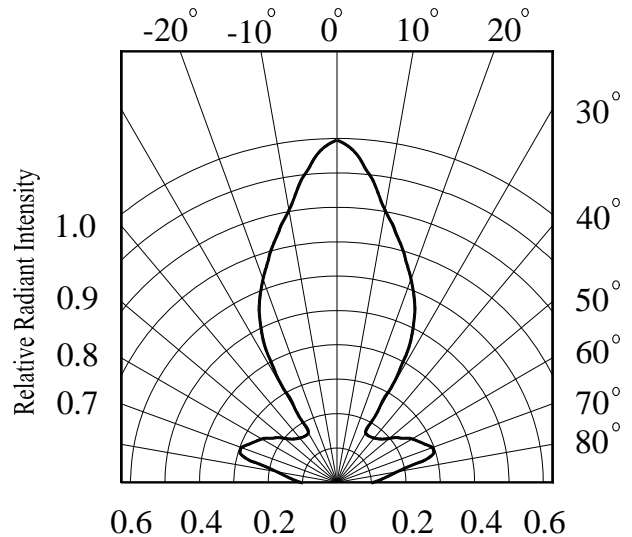

**Precautions For Use**

1. Over-current-proof

Customer must apply resistors for protection , otherwise slight voltage shift will cause big current change ( Burn out will happen ).

2. Storage

2.1 Do not open moisture proof bag before devices are ready to use.

2.2 Shelf life in sealed bag from the bag seal date:

18 months at 10°C~30°C and < 90% RH.

2.3 After opening the package, the devices must be stored at 10°C~30°C and ≤ 60%RH, and used within 1 year(floor life).

2.4 If the moisture absorbent material(desiccant material) has faded or unopened bag has exceeded the shelf life or devices(out of bag) have exceeded the floor life, baking treatment is required.

2.5 If baking is required, refer to IPC/JEDEC J-STD-033 for bake procedure or recommend the following conditions :

192 hours at 40°C +5/-0°C and < 5 % RH (reeled/tubed/loose units) or

96 hours at 60°C ± 5°C and < 5 % RH (reeled/tubed/loose units) or

24 hours at 125°C ± 5°C, not suitable for reel or tubes

3. Soldering Condition

3.1 Pb-free solder temperature profile

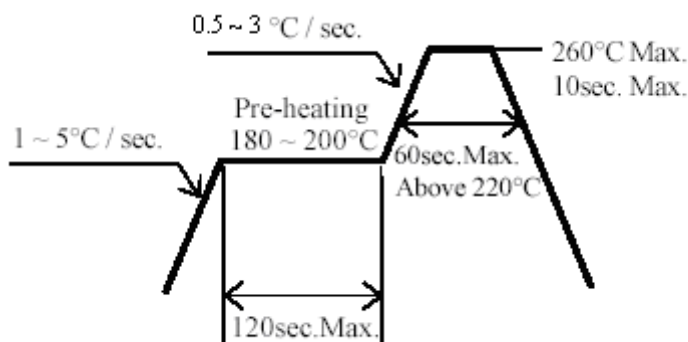

3.2 Reflow soldering should not be done more than two times.

3.3 When soldering, do not put stress on the LEDs during heating.

3.4 After soldering, do not warp the circuit board.

#### 4.Soldering Iron

Each terminal is to go to the tip of soldering iron temperature less than 350°C for 3 seconds within once in less than the soldering iron capacity 25W. Leave two seconds and more intervals, and do soldering of each terminal. Be careful because the damage of the product is often started at the time of the hand solder.

#### 5.Repairing

Repair should not be done after the LEDs have been soldered. When repairing is unavoidable, a double-head soldering iron should be used (as below figure). It should be confirmed beforehand whether the characteristics of the LEDs will or will not be damaged by repairing.

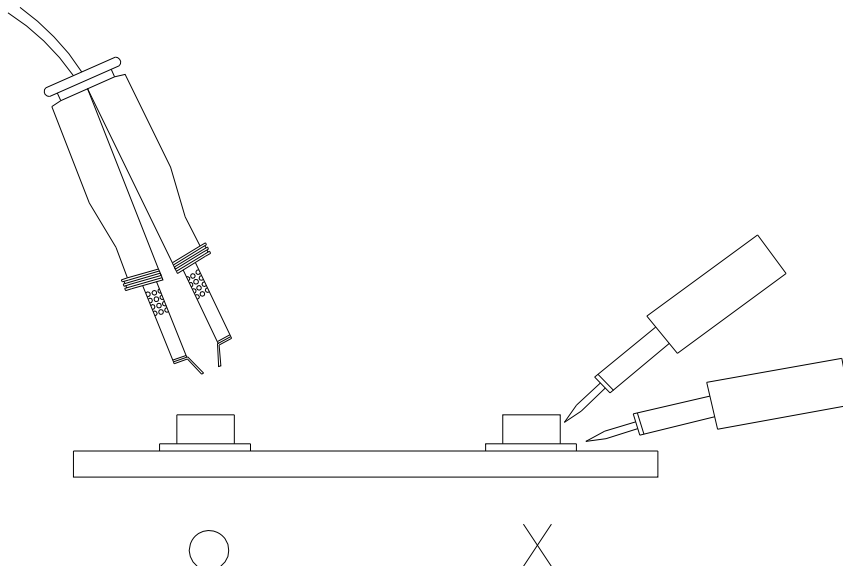

**Package Dimensions**

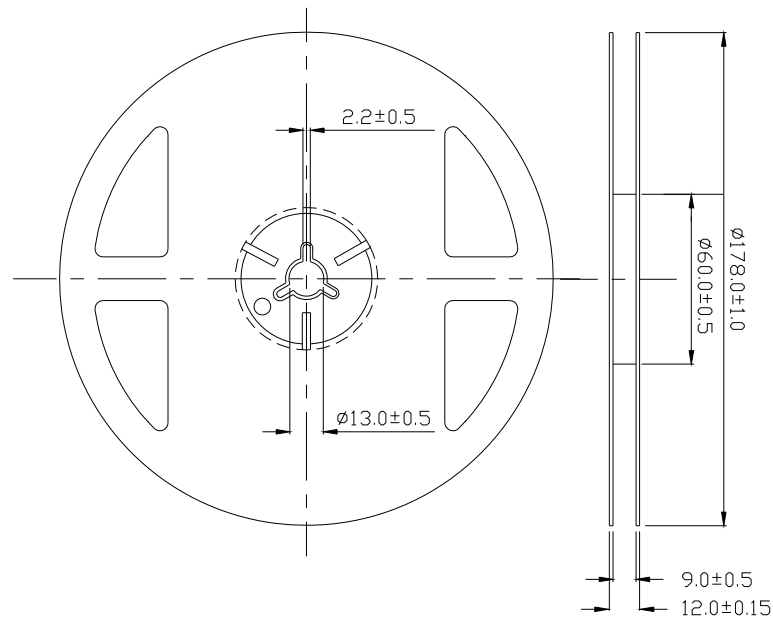

**Note:** The tolerances unless mentioned is  $\pm 0.1$ mm ,Unit = mm

**2. Carrier Tape Dimensions:(Quantity: 2000pcs/reel)**

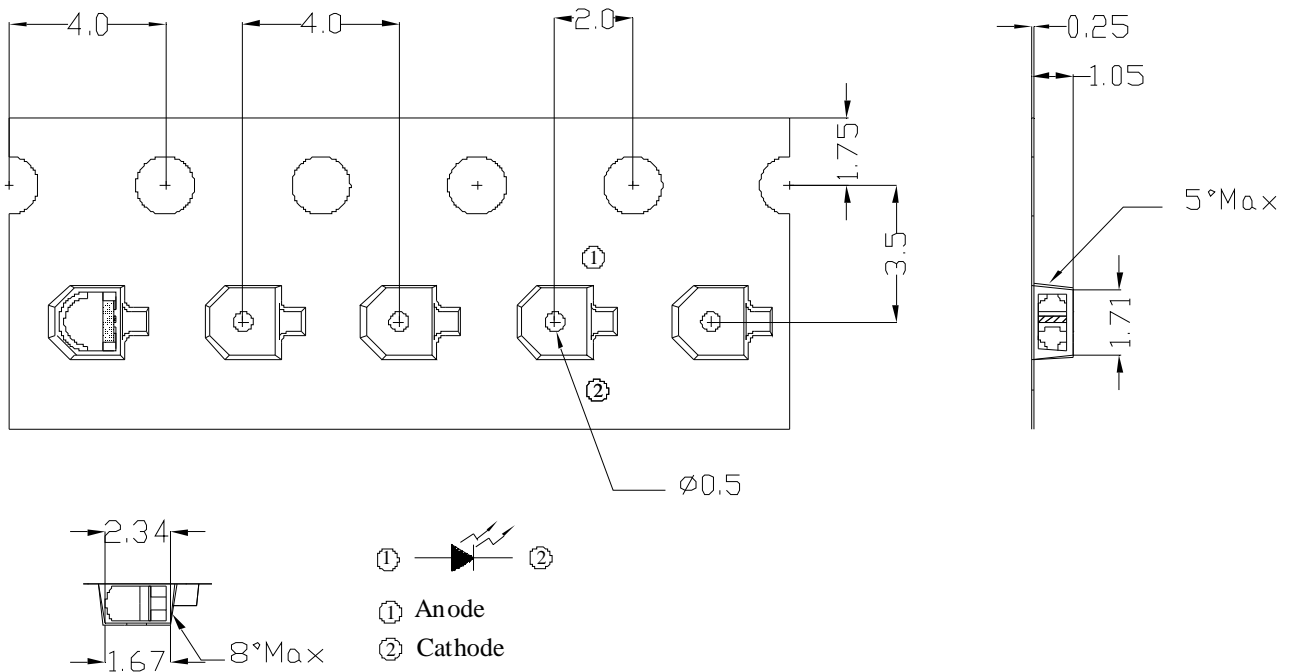

**Note:** The tolerances unless mentioned is  $\pm 0.1$ mm ,Unit = mm



**Packing Procedure**

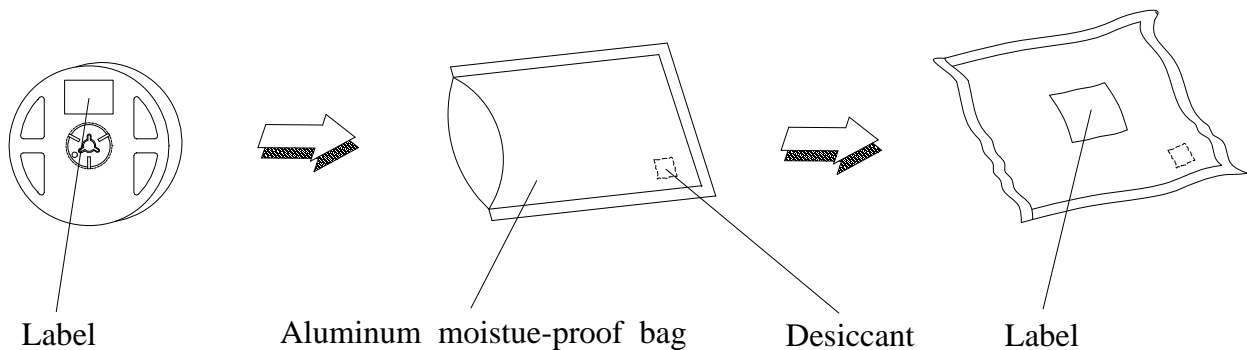

**Label Form Specification**



CPN: Customer's Production Number  
P/N : Production Number  
QTY: Packing Quantity  
CAT: Ranks  
HUE: Peak Wavelength  
REF: Reference  
LOT No: Lot Number  
MADE IN TAIWAN: Production Place

**Notes**

1. Above specification may be changed without notice. EVERLIGHT will reserve authority on material change for above specification.
2. When using this product, please observe the absolute maximum ratings and the instructions for using outlined in these specification sheets. EVERLIGHT assumes no responsibility for any damage resulting from use of the product which does not comply with the absolute maximum ratings and the instructions included in these specification sheets.
3. These specification sheets include materials protected under copyright of EVERLIGHT corporation. Please don't reproduce or cause anyone to reproduce them without EVERLIGHT's consent.

**EVERLIGHT ELECTRONICS CO., LTD.**  
Office: No 25, Lane 76, Sec 3, Chung Yang Rd,  
Tucheng, Taipei 236, Taiwan, R.O.C

Tel: 886-2-2267-2000, 2267-9936  
Fax: 886-2267-6244, 2267-6189, 2267-6306  
<http://www.everlight.com>