

**JUMO GmbH & Co. KG**  
 Delivery address: Mackenrodtstraße 14,  
 36039 Fulda, Germany  
 Postal address: 36035 Fulda, Germany  
 Phone: +49 661 6003-0  
 Fax: +49 661 6003-607  
 e-mail: mail@jumo.net  
 Internet: www.jumo.net

**JUMO Instrument Co. Ltd.**  
 JUMO House  
 Temple Bank, Riverway  
 Harlow, Essex CM 20 2TT, UK  
 Phone: +44 1279 635533  
 Fax: +44 1279 635262  
 e-mail: sales@jumo.co.uk  
 Internet: www.jumo.co.uk

**JUMO Process Control, Inc.**  
 8 Technology Boulevard  
 Canastota, NY 13032, USA  
 Phone: 315-697-JUMO  
 1-800-554-JUMO  
 Fax: 315-697-5867  
 e-mail: info@jumo.us  
 Internet: www.jumo.us



# JUMO Single Sensors

pH glass electrodes

Redox metal electrodes

Reference electrodes

Diaphragm tubes

Compensation thermometers

Glass conductivity cells

## pH glass electrodes

### Brief description

pH glass electrodes are used in conjunction with reference electrodes for measuring the pH value. The sensor portion of the pH glass electrode consists of a special pH-sensitive membrane glass. Electrodes with special membrane glasses are available for measurements in various media:

- U glass for general aqueous media
- C glass for media containing fluoride (up to 1000 mg HF/l)
- HT glass for application in temperature ranges above 80°C and in high-alkaline media

### Dimensions

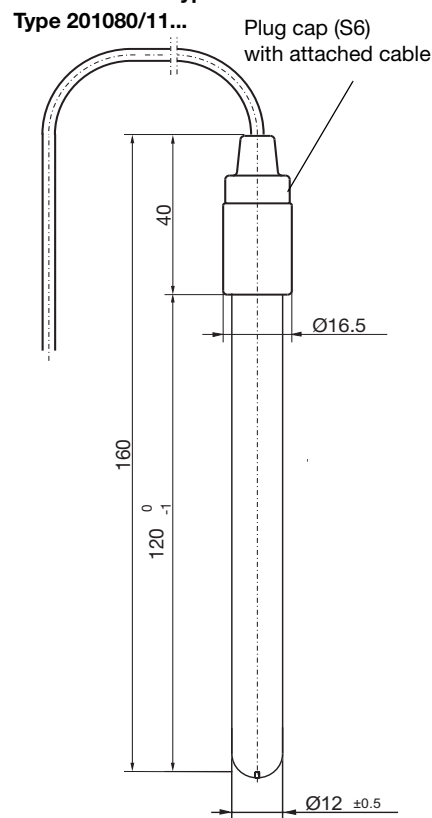
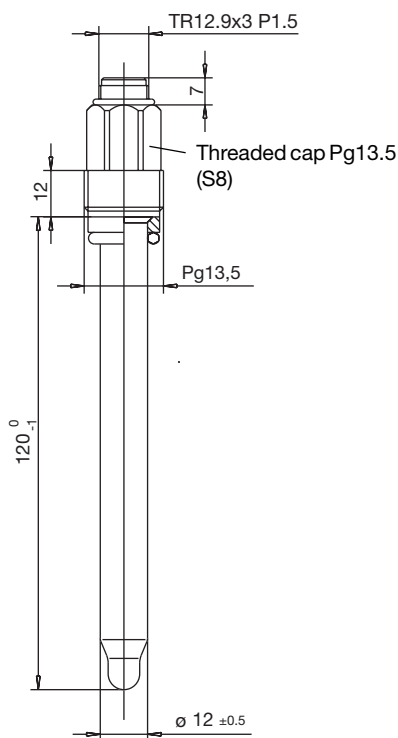
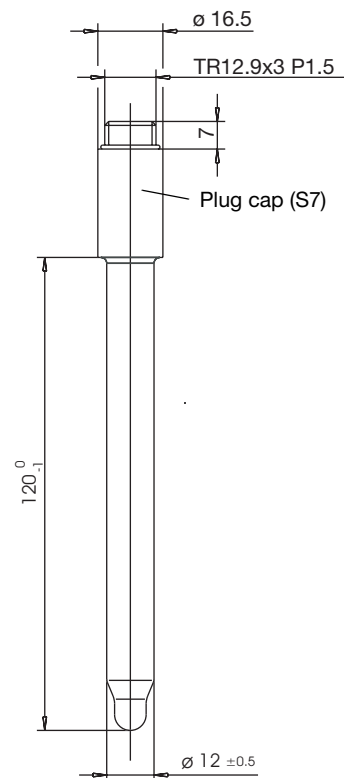

## Order details

	<b>(1) Basic type</b>	
	201080	JUMO single sensors
	<b>(2) Basic type extension</b>	
	10	pH glass electrodes
x	<b>(3) Shaft material</b>	
	89	glass
	<b>(4) Active component</b>	
x	10	U glass / pH 0 – 12 (briefly 14) / -5 to +80°C
o	11	C glass / pH 0 – 12 / -5 to +80°C / fluoride-resistant up to 1000 mg HF/l
o	12	HT glass / pH 0 – 14 / -5 to +130°C / high-temperature application
	<b>(5) Connection</b>	
o	21	plug cap (S7)
x	22	threaded cap Pg13.5 (S8)
o	40	plug cap (S6) with attached cable
	<b>(6) Length of attached cable</b>	
x	0000	none
o	xxxx	length in mm (only full meters / up to 10 m / standard length: 1000 mm = 1 m)
	<b>(7) Instrument connector</b>	
o	00	none
o	76	BNC connector
o	78	DIN connector
	<b>(8) Fitting length</b>	
x	120	fitting length 120 mm (standard)
o	225	fitting length 225 mm
		other fitting lengths on request

X = combination is standard

o = combination is optional

	(1)	(2)	(3)	(4)	(5)	(6)	(7)	(8)							
<b>Order code</b>	201080	/	10	-	89	-		-		-		-			
<b>Order example</b>	201080	/	10	-	89	-	10	-	22	-	0000	-	00	-	120

**Note:**

The type code is a type designation, not a modular system.

If at all possible, please choose the items listed under "Stock versions" or "Production versions" when placing your order.

Any free combination of individual code features must be technically checked by us and released.

Please ask us in case of doubt.

## Stock versions (delivery: 3 working days after receipt of order)

### Glass electrodes

Sales No.	Type	Brief description
20/00083302	201080/10-89-10-22-0000-00-120 (2G-2-U)	pH electrode, U glass, threaded cap Pg13.5 (S8), 120 mm

## Production versions (delivery: 10 working days after receipt of order)

### Glass electrodes

Sales No.	Type	Brief description
20/00083300	201080/10-89-11-21-0000-00-120 (2G-1-C)	pH electrode, C glass, plug cap (S7), 120 mm
20/00083301	201080/10-89-12-21-0000-00-120 (2G-1-HT)	pH electrode, HT glass, plug cap (S7), 120 mm
20/00083303	201080/10-89-11-22-0000-00-120 (2G-2-C)	pH electrode, C glass, threaded cap Pg13.5 (S8), 120 mm
20/00083304	201080/10-89-12-22-0000-00-120 (2G-2-HT)	pH electrode, HT glass, threaded cap Pg13.5 (S8), 120 mm

# Reference electrodes

## Brief description

Reference electrodes have the task of providing a constant potential for potentiometric measurements. The potential of an indicator electrode (e.g. a pH glass electrode) serves as the counterpoint. Reference electrodes feature a cartridge-style silver/silver chloride conductive system. A gelled 3-molar potassium chloride solution is used as the standard reference electrolyte. The operating temperature range is between 0 and +90°C. As an option, the reference electrode can also be supplied with a liquid KCl electrolyte. In this case, the operating temperature range is between 0 and 135°C, taking into account the maximum working temperature of the glass electrode.

## Dimensions

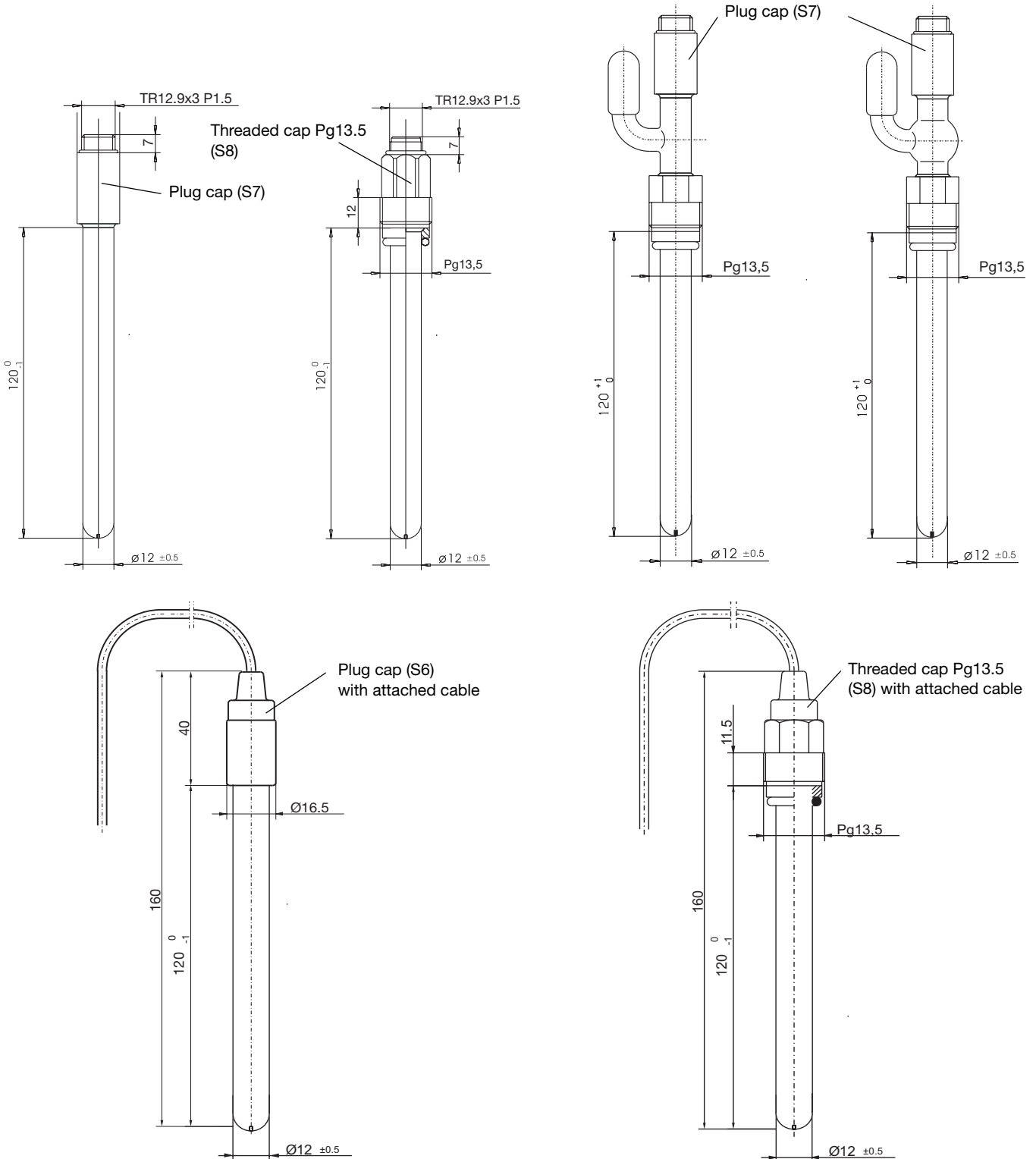

## Order details

	<b>(1) Basic type</b>	
	201080	JUMO single sensors
	<b>(2) Basic type extension</b>	
	11	reference electrodes
x	<b>(3) Shaft material</b>	
	89	glass
x	<b>(4) Electrolyte</b>	
	04	gel filling
o	05	KCl filling
	<b>(5) Diaphragm</b>	
o	04	PTFE diaphragm
x	07	1 x zirconium dioxide diaphragm (special ceramic)
o	08	2 x zirconium dioxide diaphragm (special ceramic)
o	09	3 x zirconium dioxide diaphragm (special ceramic)
	<b>(6) Connection</b>	
o	19	tube nipple, spherically enlarged shaft, threaded cap Pg 13.5 (S8/N6) cemented on
o	20	tube nipple, threaded cap Pg13.5 (S8/N6) cemented on
o	21	plug cap (S7)
x	22	threaded cap Pg13.5 (S8)
o	40	plug cap (S6) with attached cable
o	60	threaded cap Pg13.5 (S8) with attached cable
	<b>(7) Length of attached cable</b>	
x	0000	none
o	xxxx	length in mm (only full meters / up to 10 m / standard length: 1000 mm = 1 m)
	<b>(8) Fitting length</b>	
x	120	fitting length 120 mm (standard)
o	225	fitting length 225 mm
		other fitting lengths on request

X = combination is standard  
o = combination is optional

	(1)	(2)	(3)	(4)	(5)	(6)	(7)	(8)							
<b>Order code</b>	201080	/	11	-	89	-		-		-		-			
<b>Order example</b>	201080	/	11	-	89	-	04	-	07	-	22	-	0000	-	120

**Note:**

The type code is a type designation, not a modular system.

If at all possible, please choose the items listed under "Stock versions" or "Production versions" when placing your order.

Any free combination of individual code features must be technically checked by us and released.

Please ask us in case of doubt.

**Note:** Former type designations in brackets

### Stock versions (delivery: 3 working days after receipt of order)

#### Reference electrodes

Sales No.	Type	Brief description
20/00083865	201080/11-89-04-07-22-0000-120 (2B-2-G)	Reference electrode, 1 zirconium diaphragm, gel filling, threaded cap Pg13.5 (S8), 120 mm

### Production versions (delivery: 10 working days after receipt of order)

#### Reference electrodes

Sales No.	Type	Brief description
20/00083861	201080/11-89-04-07-21-0000-120 (2B-1-G)	Reference electrode, 1 zirconium diaphragm, gel filling, plug cap (S7), 120 mm
20/00083862	201080/11-89-05-07-21-0000-120 (2B-1-KCl)	Reference electrode, 1 zirconium diaphragm, KCl filling, plug cap (S7), 120 mm

## Redox metal electrodes

### Brief description

Metal electrodes consist of a glass or plastic shaft that has a metal pin or metal tip fused or glued into the lower end. Metal electrodes are used to determine the redox potential of aqueous media, in conjunction with reference electrodes. Twin metal electrodes are used for measuring the end point in amperometric titrations. The following active components are available:

- gold tip for strongly oxidizing media, for example in cyanide decontamination
- platinum tip for strongly reducing media, for example in chromate reduction
- platinum / gold pins in twin metal electrodes
- platinum / platinum pins in twin metal electrodes
- antimony for determining the pH value in media containing high levels of hydrofluoric acid

### Dimensions

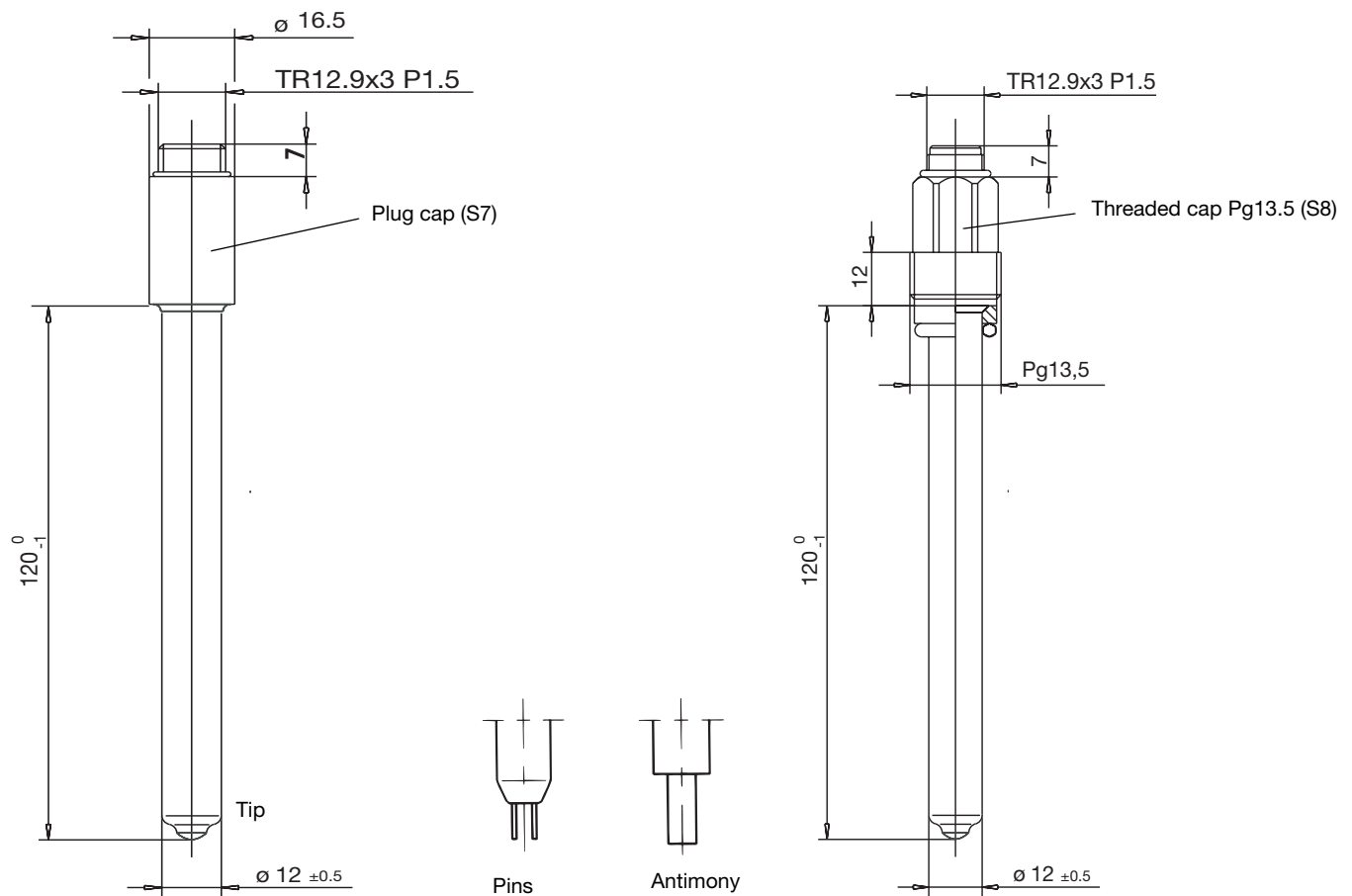

## Order details

		<b>(1) Basic type</b>	201080	JUMO single sensors
		<b>(2) Basic type extension</b>		
			12	antimony electrode for pH measurement
			13	redox metal electrode
			14	redox twin metal electrode
		<b>(3) Shaft material</b>		
	x		89	glass
	x		85	plastic
		<b>(4) Active component</b>		
	x		22	platinum tip / redox range +/-2000 mV / -5 to +135°C
			23	platinum / platinum pin / redox range +/- 2000 mV / -5 to +135°C
			24	platinum / gold pin / redox range +/- 2000 mV / -5 to +135°C
	x		27	antimony / pH 0 – 10 / -10 to +80°C / fluoride concentration larger than 1000 mg HF/l
			32	gold tip / redox range +/-2000 mV / -5 to +135°C
		<b>(5) Connection</b>		
			21	plug cap (S7)
	x		22	threaded cap Pg13.5 (S8)
		<b>(6) Fitting length</b>		
	x		120	fitting length 120 mm (standard)
			225	fitting length 225 mm
				other fitting lengths on request

X = combination is standard  
o = combination is optional

	(1)	(2)	(3)	(4)	(5)	(6)
<b>Order code</b>	201080	/		-		-
<b>Order example</b>	201080	/	13	-	89	-

**Note:**

The type code is a type designation, not a modular system.  
If at all possible, please choose the items listed under "Stock versions" or "Production versions" when placing your order.  
Any free combination of individual code features must be technically checked by us and released.  
Please ask us in case of doubt.

## Production versions (delivery: 10 working days after receipt of order)

### Redox metal electrodes

Sales No.	Type	Brief description
20/00300402	201080/13-89-22-21-120 (2M-1-PtK)	Redox metal electrode, platinum tip, plug cap (S7), 120 mm
20/00300403	201080/13-89-22-22-120 (2M-2-PtK)	Redox metal electrode, platinum tip, threaded cap Pg13.5 (S8), 120 mm
20/00325951	201080/12-85-27-22-120 (2MP-2-Sb)	Antimony electrode, threaded cap Pg13.5 (S8), 120 mm

**Note:** Former type designations in brackets

## Diaphragm tubes

### Brief description

Due to physical and/or chemical interactions between sample medium and reference system, potentiometric measurements can be disturbed or falsified by electrochemical sensors. In such cases, it is advisable to use an electrolyte bridge, which is set up with the help of a diaphragm tube (see diagram below for the construction principle). Diaphragm tubes can be manufactured from PVDF or PTFE. The diaphragm is made from PTFE and has a diameter of 5 mm.

### Dimensions

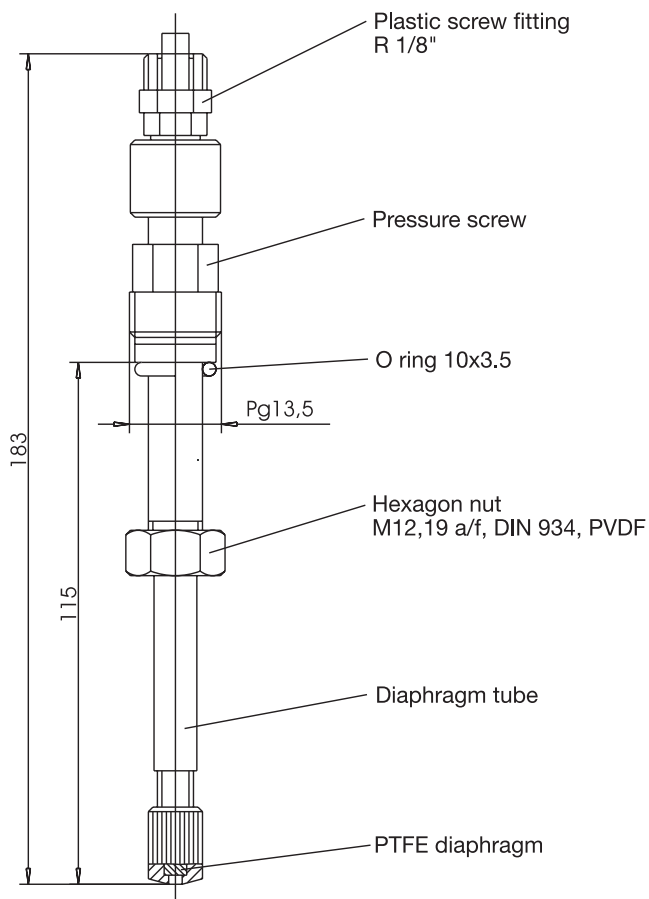

## Order details

	<b>(1) Basic type</b>	201080	JUMO single sensors
	<b>(2) Basic type extension</b>	15	diaphragm tube
x	<b>(3) Shaft material</b>	87	PP (polypropylene)
o		88	PVDF (PolyVinylidene DiFluoride)
x	<b>(4) Diaphragm</b>	04	PTFE diaphragm
x	<b>(5) Connection</b>	22	threaded cap Pg13.5
x	<b>(6) Fitting length</b>	120	fitting length 120 mm (standard)
o		225	fitting length 225 mm other fitting lengths on request

X = combination is standard

o = combination is optional

<b>Order code</b>	(1)	(2)	(3)	(4)	(5)	(6)
	201080	15		04	22	
<b>Order example</b>	201080	/ 15	- 87	- 04	- 22	- 120

**Note:**

The type code is a type designation, not a modular system.

If at all possible, please choose the items listed under "Stock versions" or "Production versions" when placing your order.

Any free combination of individual code features must be technically checked by us and released.

Please ask us in case of doubt.

## Production versions (delivery: 10 working days after receipt of order)

### Diaphragm tubes

Sales No.	Type	Brief description
20/00084582	201080/15-87-04-22-120 (2908-16)	Diaphragm tube, PTFE diaphragm, threaded cap Pg13.5, 120 mm, material: PP
20/00084583	201080/15-88-04-22-120 (2908-26)	Diaphragm tube, PTFE diaphragm, threaded cap Pg13.5, 120 mm, material: PVDF

## Accessory

Sales No.	Description
20/00304567	10 spare PTFE diaphragms

**Note:** Former type designations in brackets



# Compensation thermometers

## Brief description

Temperature errors may falsify the measurement signal during electrochemical measurements. Measurement errors due to temperature can be compensated by using compensation thermometers. Compensation thermometers acquire the temperature of the sample solution. The signal that is acquired is transmitted to a connected transmitter. The transmitter then recalculates the measured value for the 25°C reference temperature.

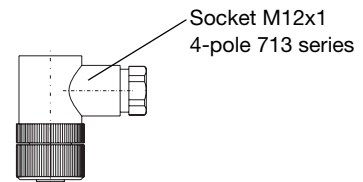

## Dimensions

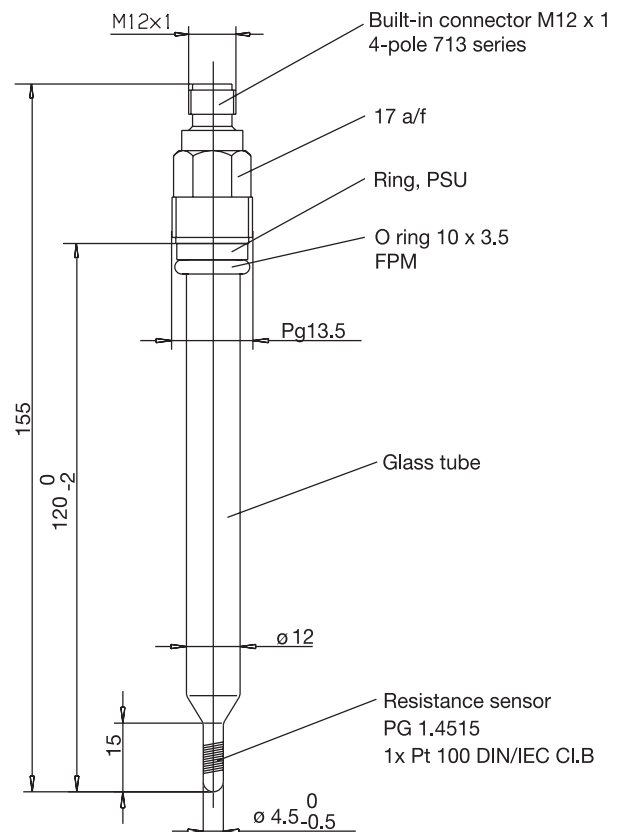
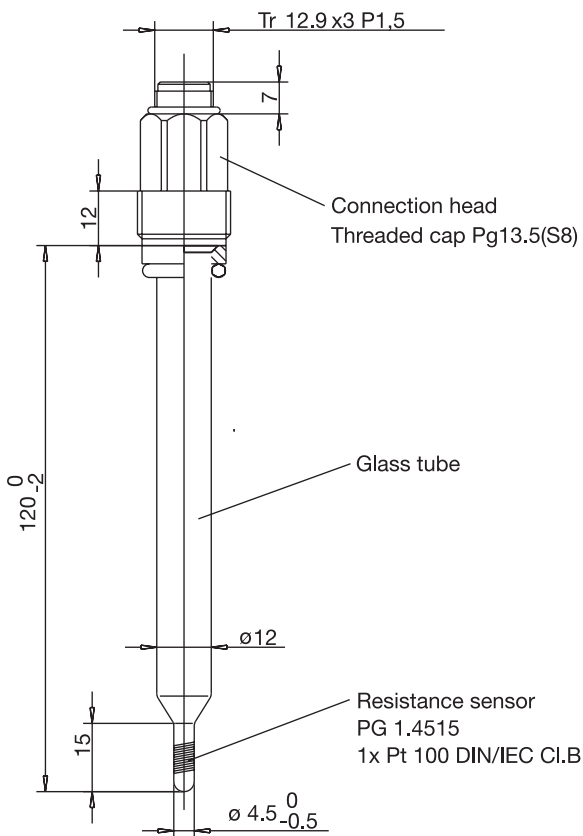

## Order details

	<b>(1) Basic type</b>	
	201080	JUMO single sensors
	<b>(2) Basic type extension</b>	
	16	compensation thermometer
x	<b>(3) Shaft material</b>	
	89	glass
	<b>(4) Active component</b>	
x	1003	Pt100 / Class B / 0 to 150°C
o	1005	Pt1000 / Class B / 0 to 150°C
o	2003	twin Pt100 / Class B / 0 to 150°C <sup>1</sup>
	<b>(5) Connection</b>	
o	21	N plug cap (S7)
x	22	threaded cap Pg13.5 (S8)
o	70	threaded cap Pg13.5 with M12 plug connector
	<b>(6) Fitting length</b>	
x	120	fitting length 120 mm (standard)

<sup>1</sup> only in conjunction with connection -70

X = combination is standard

o = combination is optional

	(1)	(2)	(3)	(4)	(5)	(6)
<b>Order code</b>	201080	/ 16	- 89	-	-	120
<b>Order example</b>	201080	/ 16	- 89	- 1003	- 22	- 120

**Note:**

The type code is a type designation, not a modular system.

If at all possible, please choose the items listed under "Stock versions" or "Production versions" when placing your order.

Any free combination of individual code features must be technically checked by us and released.

Please ask us in case of doubt.

## Stock versions (delivery: 3 working days after receipt of order)

Sales No.	Type	Brief description
20/00300443	201080/16-89-1003-22-120 (2K-2)	Compensation thermometer, Pt100, threaded cap Pg13.5 (S8), 120 mm

## Production versions (delivery: 10 working days after receipt of order)

Sales No.	Type	Brief description
20/00300442	201080/16-89-1003-21-120 (2K-1)	Compensation thermometer, Pt100, plug cap (S7), 120 mm

**Note:** Former type designations in brackets

## Glass conductivity cells

Glass conductivity cells are used to determine the electrolytic conductivity of aqueous solutions.

The cells have the cell constant  $K = 1.0 \text{ }^1/\text{cm}$ .

As an option, the cells can be supplied with an integrated Pt100 temperature probe.

The versions with a Pg13.5 threaded cap can be installed in appropriate fittings (see data sheets 20.2810, 20.2820, 20.2822 and 20.2825).

## Special features

- For electrolytic conductivity measurement in aqueous solutions
- Standard dimensions: 120 x 12 mm (DIN 19 263)
- Special styles on request
- Cell constant:  $K = 1 \pm 10\%$
- Integrated Pt100 is possible (version: Pg 13.5 threaded plug cap with M12 plug connector)
- Pressure-resistant up to 10 bar
- Ranges: platinum (raw): 0 – 1 mS/cm  
platinum (platinized): 0 – 100 mS/cm

## Order details

	<b>(1) Basic type</b>	
	201080	JUMO single sensors
	<b>(2) Basic type extension</b>	
	17	glass conductivity cells
	<b>(3) Active component</b>	
o	40	platinum (platinized), $K=1.0$
o	41	platinum (raw), $K=1.0$
	<b>(4) Connection</b>	
o	21	plug cap (S6)
x	22	threaded cap Pg13.5 (S8)
o	70	threaded cap Pg13.5 with M12 plug connector
	<b>(5) Fitting length</b>	
x	120	fitting length 120 mm (standard)
	<b>(6) Extra codes</b>	
x	000	none
o	840	with integrated Pt100 temperature probe

x = combination is standard

o = combination is optional

Order code                    (1)    (2)    (3)    (4)    (5)    (6)  
 201080 / 17 -    -    - 120 /

Order example                201080 / 17 - 40 - 21 - 120 / 000

**Note:**

The type code is a type designation, not a modular system.

If at all possible, please choose the items listed under "Stock versions" or "Production versions" when placing your order.

Any free combination of individual code features must be technically checked by us and released.

Please ask us in case of doubt.



Type 201080/17...

**Stock versions** (delivery: 3 working days after receipt of order)

Sales No.	Type	Brief description
20/00303396	201080/17-89-40-22-120/000 (2LF-2-Pt)	Glass conductivity cell, threaded cap Pg13.5 (S8), platinum (platinized), 120 mm, K=1.0

**Production versions** (delivery: 10 working days after receipt of order)

Sales No.	Type	Brief description
20/00300408	201080/17-89-41-22-120/000 (2LF-2-Pt)	Glass conductivity cell, threaded cap Pg13.5 (S8), platinum (raw), 120 mm, K=1.0
20/00442442	201080/17-89-40-70-120/000 (2LF-2-Pt)	Glass conductivity cell, threaded cap Pg13.5 with M12 connection, platinum (platinized), 120 mm, K=1.0

**Note:** Former type designations in brackets