

IdeaWerk Plus 3D Printer

User Manual

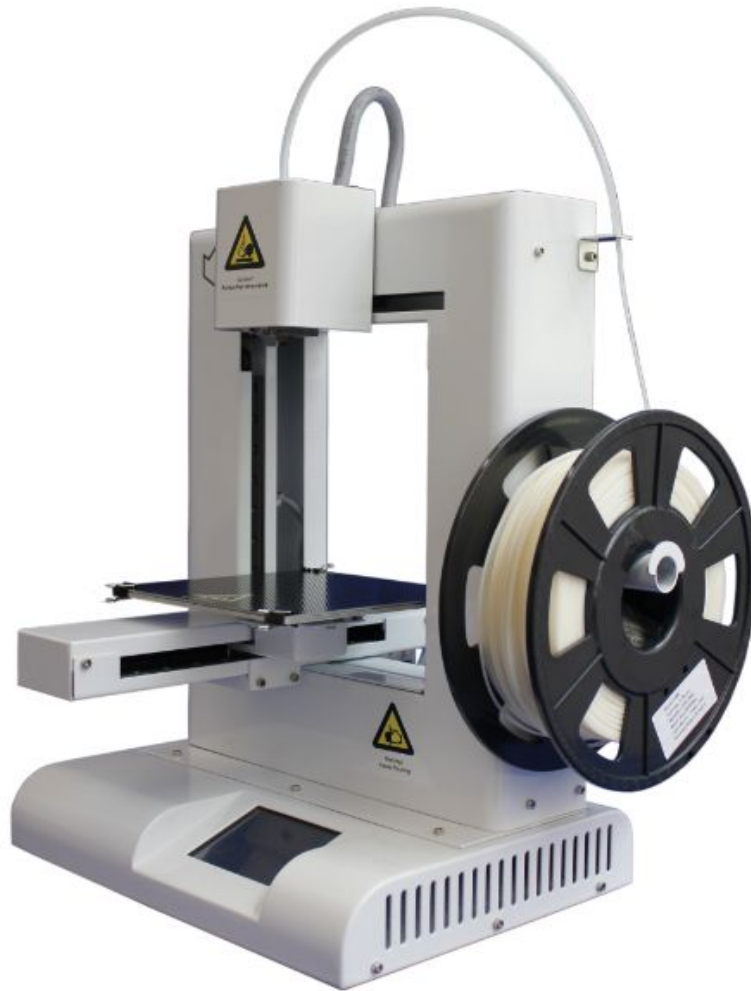

Statement

- **This manual contains important information about installation, use, maintenance and storage of the product. Please read it carefully before use of the product and backup it.**
- **Weitek is entitled to modify the IdeaWerk Plus and relevant content in the manual without notice.**
- **Weitek is not responsible for any loss (including sequent loss) caused by reference to the manual, including the loss due to printing or other publishing errors.**
- **Without authorization of Weitek, any organization or individual is forbidden to modify, copy, reproduce or translate the manual.**
- **This manual is copyright-protected and Weitek reserves the right of final interpretation.**

© Copyright 2014 Shenzhen Weitek Co., Ltd. All Rights Reserved

Contents

Important notes.....	1
I. Overview.....	1
1.1 Introduction.....	1
1.2 Technical parameters.....	1
II. Preparations.....	2
2.1 Out-of-box audit.....	2
2.2 Accessories assembly.....	2
III. Offline operation.....	3
3.1 Touch screen function.....	3
3.2 Print from USB flash disk.....	7
3.3 Print from USB flash disk notes.....	8
IV. Print from PC.....	9
4.1 Installation notices	9
4.2 Software installation.....	9
4.3 Interface and function.....	10
4.4 Print from PC.....	20
4.5 Print from PC notes.....	20
V. After-sale service contact.....	21
Annex 1 Maintenance.....	22
Annex 2 Tips and Tricks.....	22

Important notes

- During printing, do not touch the power cord or the USB cable or unplug the USB flash drive. Otherwise, it may interrupt the printing.
- Before the molten filament comes out from the nozzle, do not heat the extruder for a long time to avoid clogging.
- During calibration, please keep a distance of more than 50mm between the nozzle and the build plate, otherwise it may cause nozzle clogging.
- When ABS material melts at high temperature, a small amount of smoke will be released along with a slight smell. It is recommended to use the product in a well-ventilated environment.
- **⚠** In the operation of the extruder, do not put your hand into the IdeaWerk Plus to avoid wound or burn.
- **⚠** Do not place the printer in an environment with much dust, high moisture or intense sunlight.
- **⚠** Do not use the printer on a tilted surface, because the IdeaWerk Plus may fall, damage or hit other items.
- **⚠** Please wear protective gloves to separate models on the platform to avoid burn or scratch.

I. Overview

1.1 Introduction

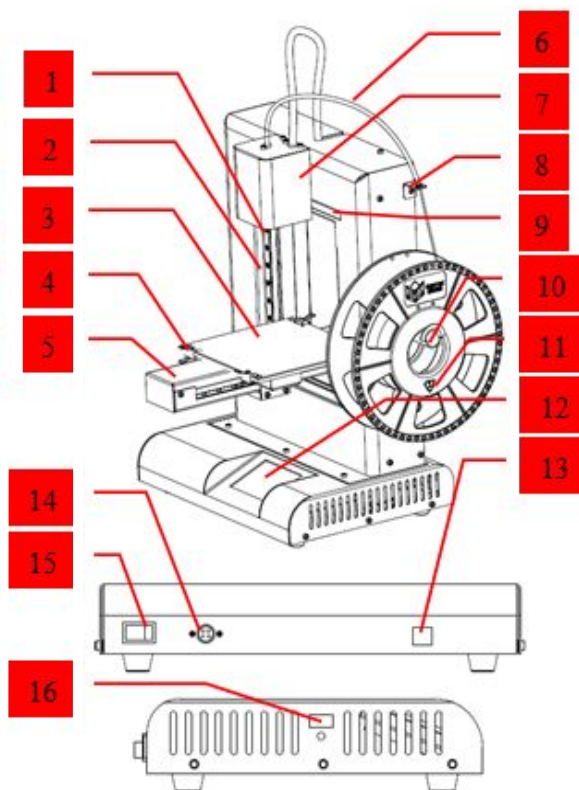

- | | | |
|------------------------------|-----------------------|------------------|
| 1. Nozzle | 2. Z-axis | 3. Build plate |
| 4. Clamp | 5. Y-axis | 6. Teflon tube |
| 7. Extruder | 8. Filament assistant | 9. X-axis |
| 10. Spoon holder | 11. Filament disk | 12. Touch panel |
| 13. USB cable interface | 14. Power input | 15. Power switch |
| 16. USB flash disk interface | | |

1.2 Technical parameters

- **Operating environment**
 - Operating temperature: 5 °C - 35 °C
 - Relative humidity: 30%-90%
- **Electrical parameters**
 - Power input: 100-240V AC, 1.5A, 50-60Hz
 - Power output: 19V/DC, 9.5A
 - Maximum power: 180W
- **Print parameters**
 - Print size: 150(L)×150(W)×140(H)mm
 - Print thickness: 0.2-0.3mm
 - Print speed: 30-150 cm^3/h
 - Platform temperature: 0-100 °C
 - Extrusion temperature: 0-300 °C
- **Filament parameters:**
 - Diameter: 1.75mm
 - Materials: PLA/ABS
 - Recommended temperature: PLA: 220-230 °C; ABS: 230-240 °C
- **Software parameters**
 - Printing software: DoraWare-P
 - File format: STL/GCODE/WTK
 - Applicable system: Windows XP/Vista/7/8/8.1
- **Structural parameters**
 - IdeaWerk Plus size: 298(L)×221(W)×403(H)mm
 - Package size: 496(L)×376(W)×356(H)mm
 - Net weight: 7.68kg
 - Gross weight: 12kg

II. Preparations

2.1 Out-of-box audit

- Please check the product after the box is open, and in case of any surface scratch or damage, please contact local dealer or our after-sales service.
- Check the accessories in accordance with the product packing list, and in case of any missing, please contact local dealer or our after-sales service.

2.2 Accessories assembly

2.2.1 Open the toolkit, as shown in the following figure.



2.2.2 Assembly of spoon holder: take out the two screws in the middle of the right side of the IdeaWerk Plus and fix the spoon holder with the screws. Note that the rib is on the upper side.



2.2.3 Assembly of filament card: take out the screw at the back of the upper right side of the IdeaWerk Plus and fix the filament card with the screw.



2.2.4 Fixation of hotbed panel: fix the hotbed panel on the build plate with four clamps.

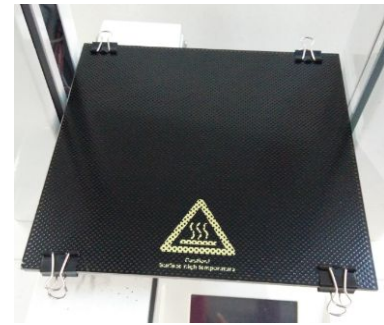

2.2.5 Preparation of filament rod: The filament free end must be cut to be flat. Please keep it straight as well.



2.2.6 Hang the feed disk on the spoon holder and put the filament through the filament card.



2.2.7 Pass the filament through Teflon tube



2.2.8 Power on: plug the output end of the power adapter into the power interface on the IdeaWerk Plus.



III. Offline operation

3.1 Touch screen function

3.1.1 Power on, the touch screen brightens and the buzzer beeps. The touch screen is shown as below.



3.1.2 Click any position of the screen and enter the operation interface. In the menu of "Print", the column of "File" displays the name of the file to be printed. If the USB flash drive is not inserted, the inverted triangle is grey.

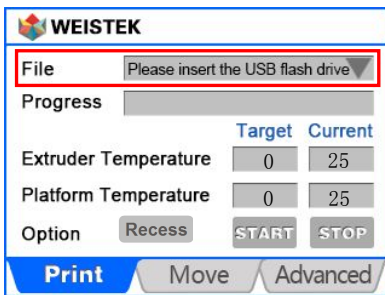

3.1.3 After the USB flash drive is inserted, the inverted triangle turns blue, and the pull-down menu displays the file to be printed.

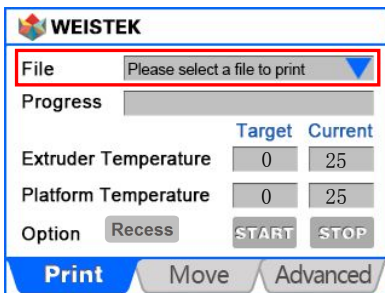

3.1.4 Choose the file to be printed such as "CUBE". The printing interface pops up and the button "START" turns blue from grey, which indicates that the printing can be started. Temperatures of the extruder and the build plate are set as shown in the figure.

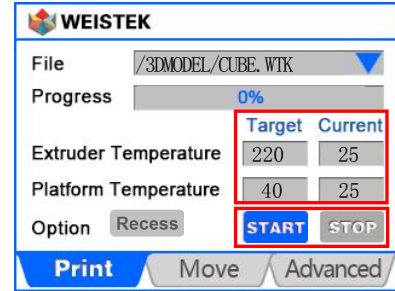

3.1.5 Click "START" to begin printing. If the extruder or the build plate's temperature does not reach the set value, the IdeaWerk Plus will first heat it (note: the platform will be first heated till its temperature rises to the set value, and then the extruder will be heated. Only when the extruder's temperature rises to the set value, the IdeaWerk Plus begins to print, so the platform's temperature should be set no less than the ambient temperature).

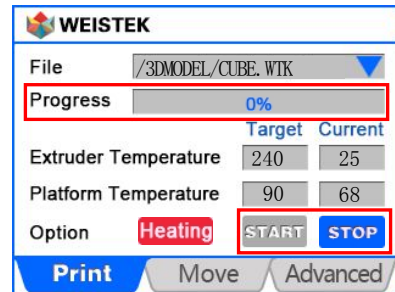

3.1.6 Printing will start once the heating is completed. "Progress" displays progress of printing with the unit of 1%. "Option" is the current state of the IdeaWerk Plus, which is displayed as "Recess" when there is no print task, as "Heating" when the IdeaWerk Plus is heated and as "Printing" when the printing is underway.

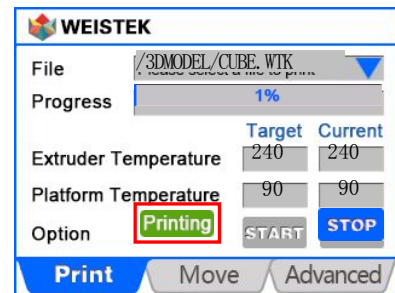

3.1.7 To cancel the printing, click "STOP" and the following interface appears.

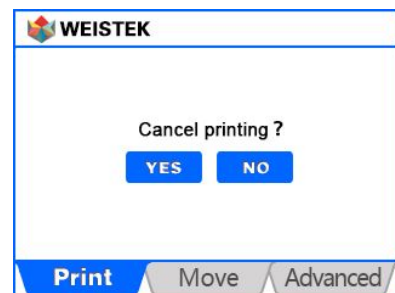

3.1.8 After the model is printed, the following interface will pop up, and click "OK" to complete the printing.



3.1.9 Click the “Move” menu to enter the movement and temperature interface. The left is for the temperature setting and the electromechanical control of the extruder, and the right for three-axis movement control. Press the button of X/Y/Z movement, the IdeaWerk Plus will move to the corresponding direction. Click “Home” and each moving part of the IdeaWerk Plus will go back to the original location.

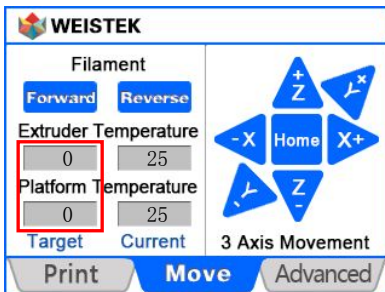

3.1.10 Click “Target” for temperature setting, a numeric keypad pops up, and you can further set the temperature of the extruder and the platform. The setting range of the platform’s temperature is 0-100 °C and that of the extruder is 190-280 °C. For PLA material, the platform temperature can remain unset, and the extruder temperature can be set at 220-230 °C; for ABS material, the platform temperature can be set at 80-100 °C according to the size of the model, and the extruder temperature can be set at 230-240 °C.

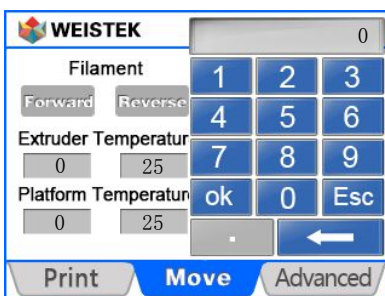

⚠ Notice: do not frantically click the touch screen!

3.1.11 If the temperature is not set at this moment, the default temperature of printing from USB flash disk is that set by GCODE, and if the temperature is set, the printing will proceed at the set temperature. This setting is only effective at this time, and if the parameter is used next time, it needs to be reset. The interface after temperature setting is shown as follows.

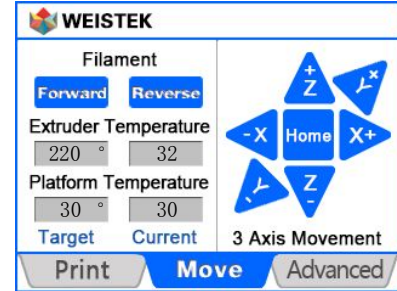

3.1.12 After the extruder temperature rises to the set value, click “Forward”, and insert the prepared filament into the extruder’s feed port till the extruder catch the filament. After a few seconds, you can see fine filament out of the nozzle. Click “Stop”, and the extruder stops. At this moment, the interface is as shown in the following figure.

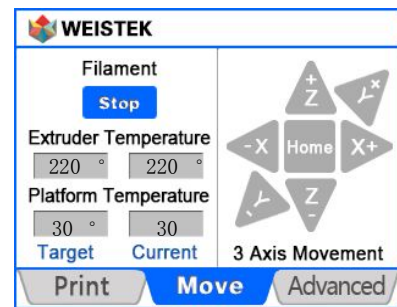

3.1.13 If the printing is suspended for a long time, to avoid clogging next time, take out the filament inside the extruder. After the extruder temperature rises to the set value, click “Reverse”. After the filament returns completely, take it out, and click “Stop”.

⚠ Notice: only after the extruder temperature rises to the set value, the feeding and returning of the filament can be carried out, or else it is likely to cause extruder clogging.

3.1.14 In the interface “Advanced”, “Units of Temperature” is the option of temperature unit. The default unit is “°C”, and you can also select “°F”.

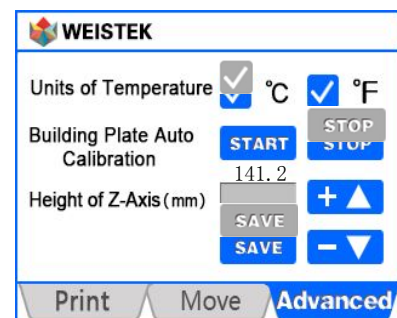

3.1.15 “Building Plate Auto Calibration” is the automatic detection of the platform. Press “Z+” in the interface “Move”, and raise the platform to about 1mm from the nozzle.



3.1.16 Click "START", the platform will move along the direction shown below. At this moment, you can observe the distance between the nozzle and the platform. If it is equal all the time, the platform has been leveled. Click "STOP" to stop the movement. If not, the platform needs to be debugged in accordance with the following steps.

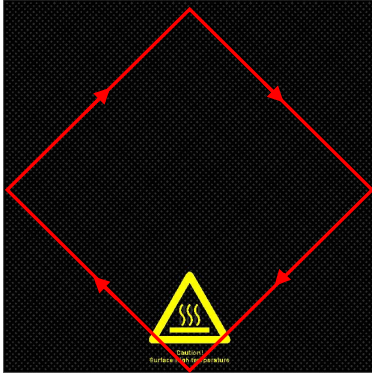

3.1.17 Click "X-" or "X+" to move the extruder to the central axis of the platform.



3.1.18 Click "Y-" or "Y+" to move the platform back and forth to observe whether the distance between the nozzle and the platform is equal all the time.



3.1.19 If the distance is equal, enter the next step. If not, adjust the screw fixing the platform till it is equal.

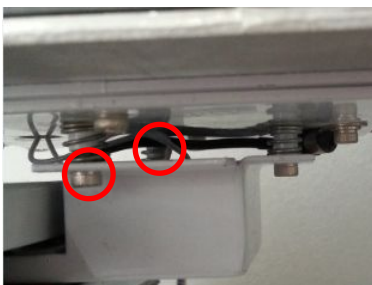

3.1.20 After determining the direction of Y-axis, move the platform to make the extruder in the center. Click "X-" or "X+" to move it left and right.

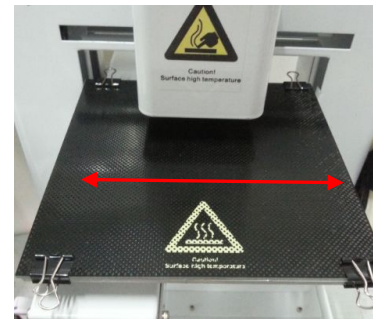

3.1.21 In the left and right movement, observe the distance between the nozzle and the platform. If it is equal all the time, enter the next step. If not, adjust the screw fixing the platform till it is equal.

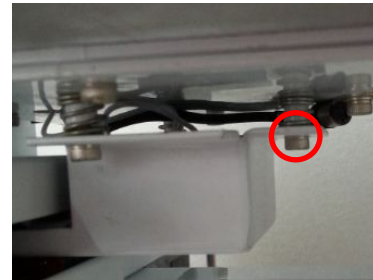

⚠ Notice: the platform may be adjusted repeatedly from 3.1.15 to 3.1.21 to ensure equal distance between the nozzle and the platform. Once confirmed, it does not need frequent adjustment.

3.1.22 "Height of Z-Axis (mm)" is the distance from the lowest position to the highest position of the platform. This height is a key factor affecting the success of the model printing. The printing height has been set before the IdeaWerk Plus leaves factory, and if the platform is adjusted or the printing height changes after a period of time of use, fine-tune this value. During printing, if the model sticks to the hotbed panel tightly and it is difficult to remove the model, you can click "-▼", and the figure in the display frame will be reduced by 0.1mm. If the model sticks to the hotbed panel loosely, the model tends to have warping edge or fall off, click "+▲", and the figure in the display frame will be increased by 0.1mm. After adjustment, click "SAVE", and the model will be printed at this height next time.

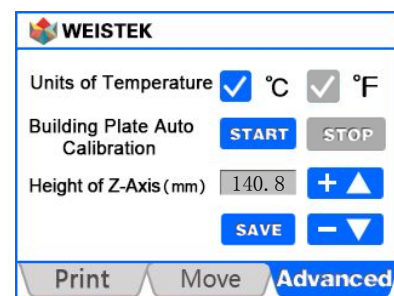

3.1.23 To modify Z-axis height, you can also directly click the display frame, and a numeric keypad will pop up. Input the height value(mm) you want, click "OK" to return to the interface "Advanced", and click "SAVE".

⚠ Notice: you need to input a four-digit figure (including the digit next to the decimal point, but no need to input the decimal point), and the system will automatically add a decimal point. If the height you want is 140mm, you need to input "1400" and click "SAVE".

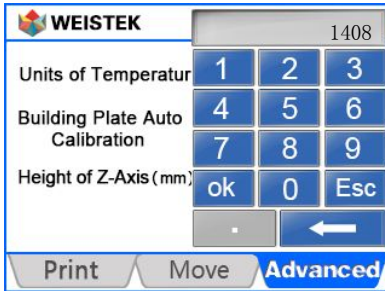

3.1.24 The following prompt will pop up when you click "SAVE", and click "OK" to complete the setting.

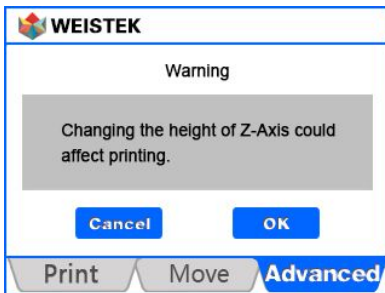

3.1.25 If the IdeaWerk Plus is successfully connected with computer software, the following interface will be displayed. The system will automatically switch to the offline state 10 seconds after the software and the IdeaWerk Plus are disconnected, and the start-up interface will be then displayed.

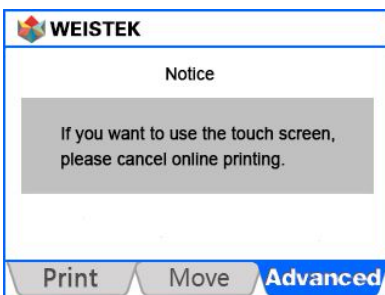

3.2 Print from USB flash disk

Take the model "CUBE" for example to illustrate the process of printing from USB flash disk.

3.2.1 Turn on the power switch, reset the IdeaWerk Plus and click to enter the user interface. Insert the USB flash drive into the IdeaWerk Plus, and the interface is shown as follows.

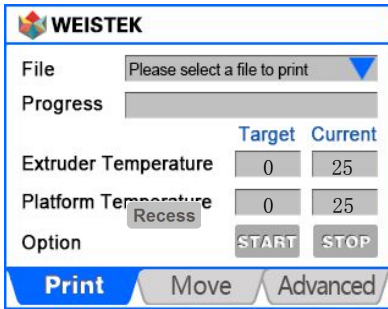

3.2.2 Click the file display frame to enter the model selection interface, and click "/3DMODEL/CUBE.WTK" to select the model "CUBE", as shown below.



3.2.3 Enter the interface "Print" and click "START" to heat the extruder and the platform. PLA material is used in this model, so the extruder temperature is set at 220 °C and the platform temperature is set at 30 °C.

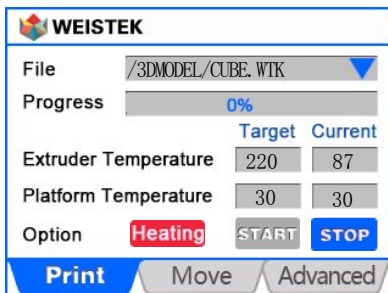

3.2.4 After the platform and the extruder are heated to the target temperature, the IdeaWerk Plus starts printing.

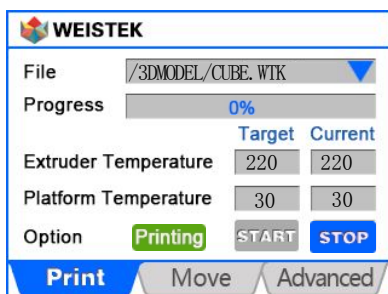

3.2.5 The printing is in progress, 82% completed, as shown in the interface below. ⚠ Notice: since the progress is displayed by 1%, if the model is large, the change of the progress bar may be seen after the printing proceeds for a long time, and if the model is small, it is possible to see the progress skipping by 1%.

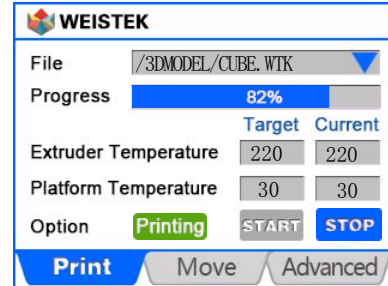

3.2.6 After the model printing is completed, the object is as shown in the following figure.

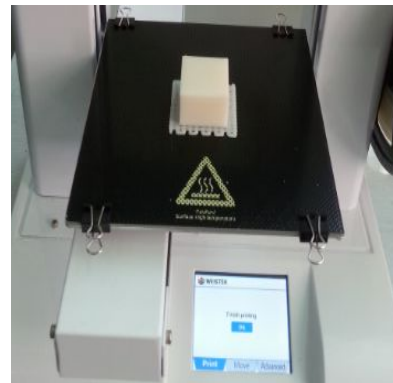

3.2.7 Click "OK" to complete the printing.

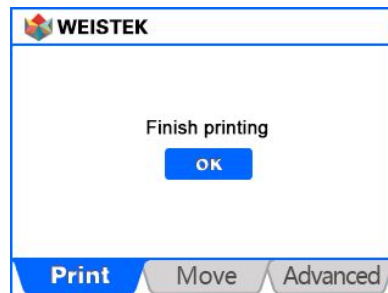

3.2.8 Remove the four clamps, and take down the model with a shovel.

⚠ Notice: wear gloves when removing the model to prevent burn by the hot platform!

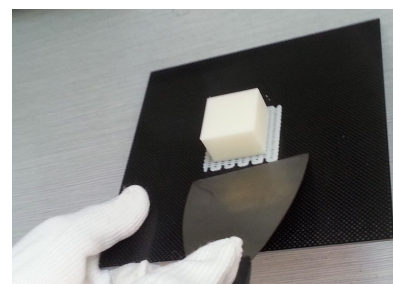

3.2.9 After removing the model, fix the hotbed panel again with four clamps on the build plate.

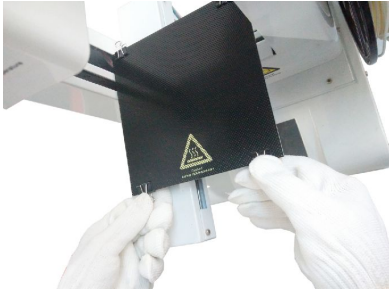

3.3 Print from USB flash disk notes

3.3.1 The maximum memory of the USB flash drive model recognized by this IdeaWerk Plus is 32GB.

3.3.2 This IdeaWerk Plus can recognize up to 58 model files in the USB flash drive, and it is recommended to store no more than 20 model files.

3.3.3 If the USB flash drive has been inserted but the IdeaWerk Plus can not find the device, it is possible that the the USB flash drive is inserted before the IdeaWerk Plus is powered on, or it contains too many model files. You can pull it out and re-insert it.

If the computer can recognize the USB flash drive, but the IdeaWerk Plus can't, you can format it in the default mode of the operating system.

3.3.4 If the USB flash drive is formatted or a new USB flash drive is used for printing from USB flash disk, be sure to create a new folder named "3DMODEL" in the USB flash drive directory where offline print files are stored. If the folder is created in any other folder or the offline print files are stored elsewhere, the IdeaWerk Plus can not recognize.

3.3.5 The file name can be in Chinese or English. The length is not more than four Chinese characters or eight English letters, and if exceeded, the excessive part will be shown as "~ 1". For example: "High-Tech Product.WTK" will be shown as "High-Tech~1.WTK" and "PRINTMODEL.WTK" will be shown as "PRINTM ~ 1.WTK".

3.3.6 The file name shall contain no special character.

3.3.7 During the printing, the platform temperature can not be set below the room temperature, otherwise the extruder can not print properly.

3.3.8 ABS material has relatively high shrinkage, and the recommended ambient temperature is 20 °C-32 °C, because the low ambient temperature will affect the effect of model printing.

IV. Print from PC

4.1 Installation notices

Before software installation, please read the following tips:

4.1.1 The software installer is in the USB flash drive, please copy it to the computer and backup it.

4.1.2 If the computer is installed with anti-virus software or firewall, please close it before software installation.

4.1.3 If the computer is set with administrator privileges, please obtain permission first before installation.

4.1.4 The following example of software installation is carried out in Windows 7 System, and due to differences between systems, the installation in the other systems may be different from the example.

4.2 Software installation

4.2.1 The installer is applicable for 32-bit and 64-bit operating systems, so please select the corresponding installation package according to the computer system. The installation process is demonstrated in 32-bit operating system. Double-click to select "DoraWare-P-Setup-32.exe", and the following interface pops out.



4.2.2 Click "Browse ..." to select the installation location.

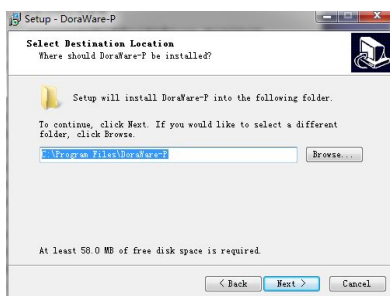

4.2.3 Click "Next" to continue.

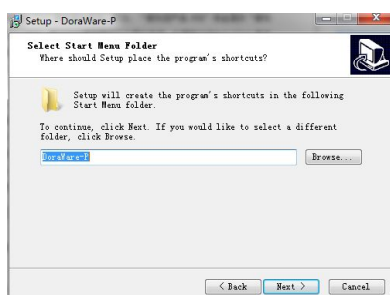

4.2.4 Choose to create a desktop icon or not.



4.2.5 Click "Install".

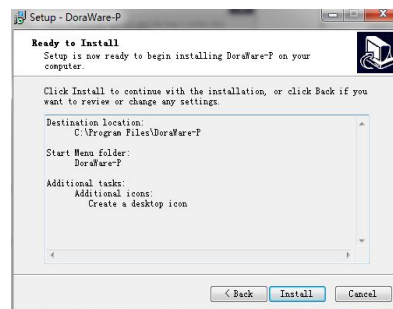

4.2.6 Software installation is in process.

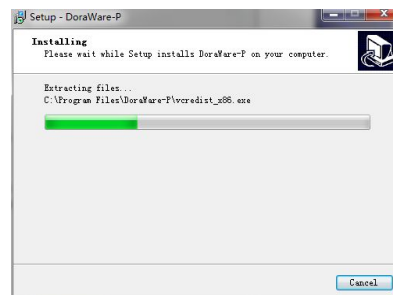

4.2.7 After the software installation, the driver installation prompt pops out, and click "Next" to continue.

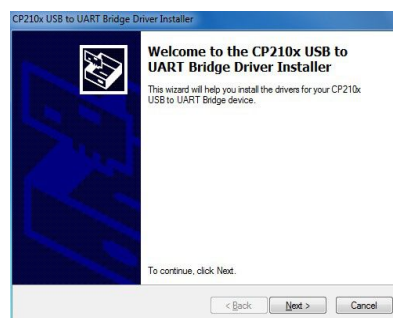

4.2.8 In the following pop-up interface, select "I accept this agreement (A)" and click "Next" to continue.



4.2.9 In the pop-up interface, click “Finish” to complete the driver installation.

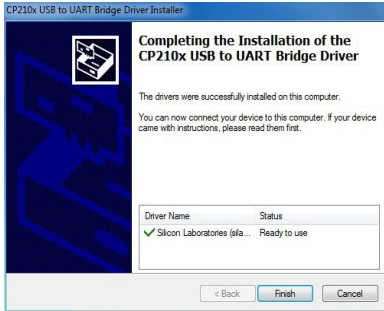

4.2.10 Click “Finish” to complete the entire software installation.



4.3 Interface and function

4.3.1 Turn on the power switch, and double click “DoraWare-P” on the desktop to open software.

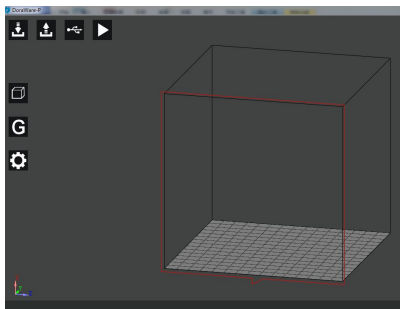

4.3.2 In the software interface, the bar “1” at the top left corner is the function menu. Move the mouse to the menu icon, and corresponding functional description will be displayed; the bar “2” at the lower left corner is schematic three-dimensional coordinates; the middle bar “3” is model display area, and the side with red lines faces the operator; the bottom bar “4” is for status display, indicating the temperature and model information.

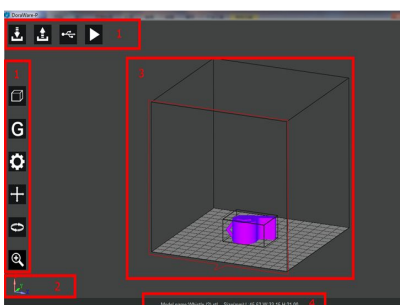

4.3.3 Import model

4.3.3.1 Click the icon “Load”, and the dialog pops out to look up the model path. After selecting the model, click “Open”. The model with imported software is as shown in Figure 4.3.2.

⚠ Notice: if you want to open a previously generated GCODE file, you need to store the STL file and the GCODE file in the same folder. Import the STL file to open the GCODE file, without a new GCODE.

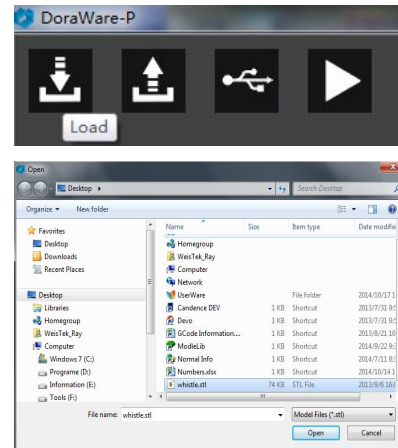

4.3.3.2 Click “Load” again, and you can import multiple models. **⚠**

Notice: no more than the platform area, otherwise the models printed may overlap.

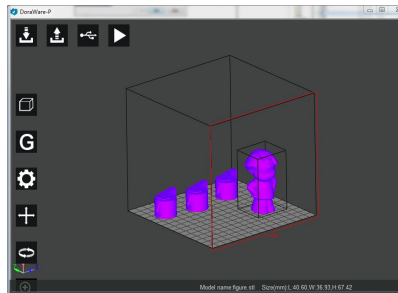

4.3.4 Generate a file

4.3.4.1 Click the icon “Export”, and the dialog box to save the file path pops out. Select the save path and click “Save”, and software automatically generates the printing from USB flash disk file.

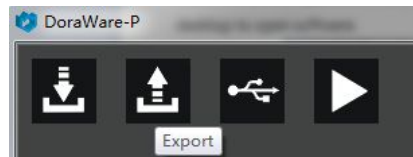

4.3.4.2 **⚠ Notice:** do not modify its suffix format when you save an offline file, otherwise the IdeaWerk Plus will not recognize the file.

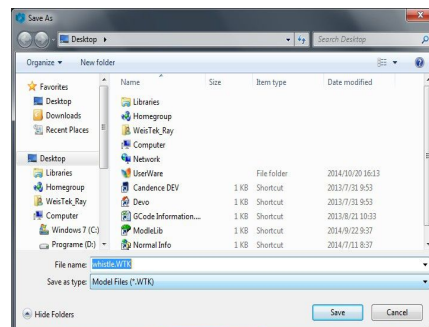

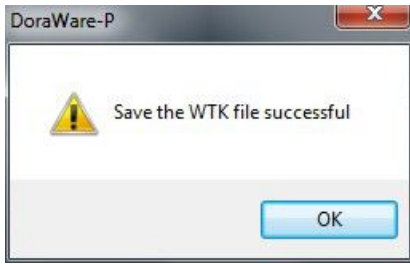

⚠ **Notice:** if the model does not generate GCODE, click "Export", it cannot generate a file, and the following message box will pop out.



4.3.5 Connect the printer with PC

4.3.5.1 Click the icon "Setting" to open the IdeaWerk Plus connection dialog.

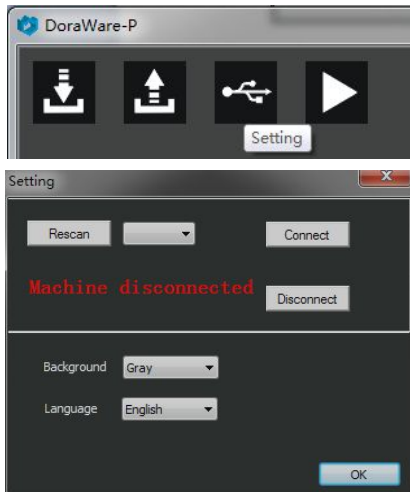

4.3.5.2 Click "Rescan" and "▼", as shown below.

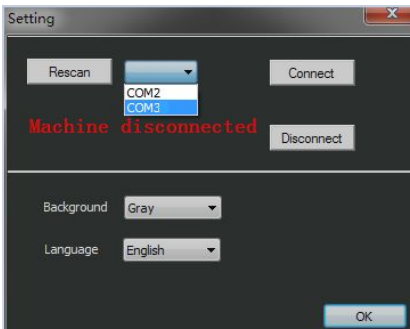

4.3.5.3 Select the corresponding port of the IdeaWerk Plus. For example, this IdeaWerk Plus is “COM3”. Click “Connect”.

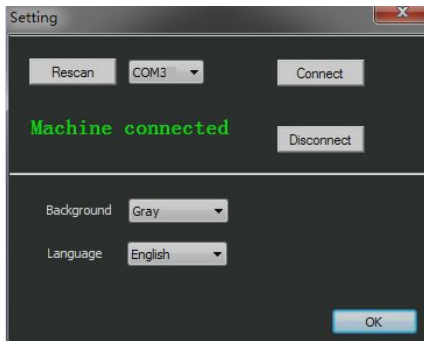

4.3.5.4 To disconnect the IdeaWerk Plus and software, click “Disconnect”.

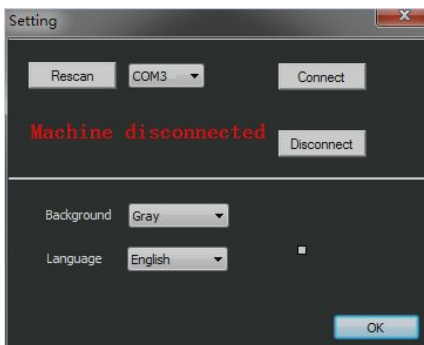

4.3.5.5 Change the background color: click the icon after “background”, and there are three kinds of background images to choose from.

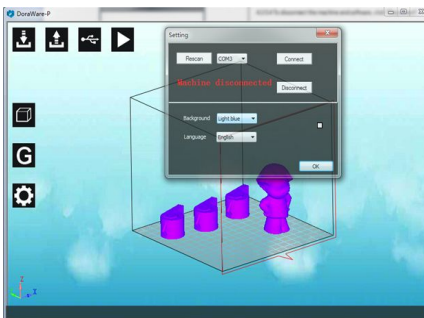

4.3.5.6 Click the pull-down button after “Language” to choose Chinese or English”.

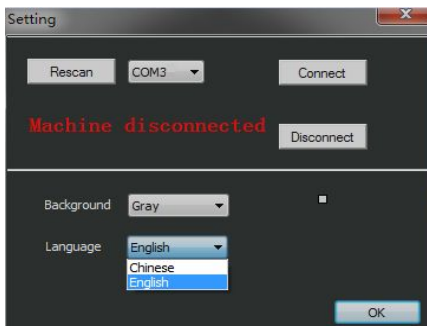

4.3.5.7 After successful connection, the icon in the interface turns green from white, as shown below.

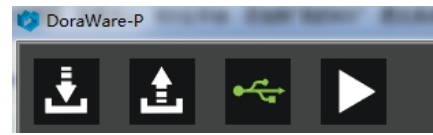

4.3.5.8 After the GCODE file is generated or opened, click the icon “Start Print”, and the IdeaWerk Plus start print.

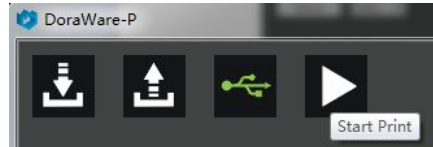

4.3.5.9 To stop printing, click the icon “End Print”.



4.3.6 Control models with mouse

4.3.6.1 Click with the left mouse button to select the model, the size of the model is displayed in the status bar at the bottom in terms of the outer wall’s length, width and height, and a transparent box will surround the model to show the selected status.

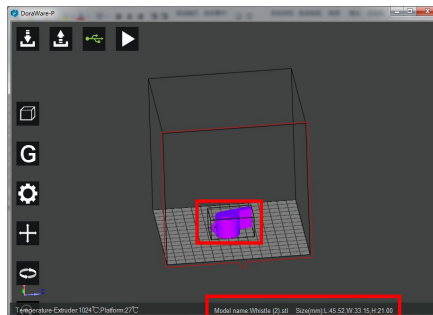

4.3.6.2 After the model is selected, the edit menu icons hidden on the left will appear, as shown in Figure 4.3.7.1. If the model is not selected, the icons are hidden.

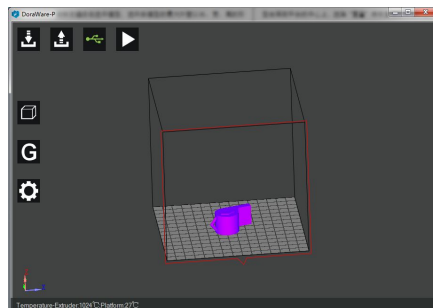

4.3.6.3 Click the right mouse button to move, and the model display frame can be rotated at any angle.

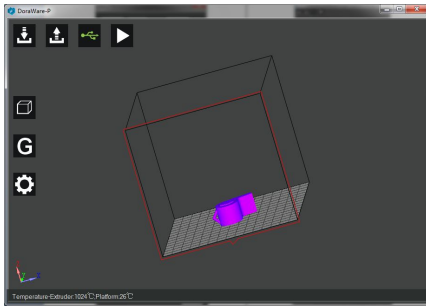

4.3.6.4 Hold the middle mouse button, and you can move the overall model display frame.

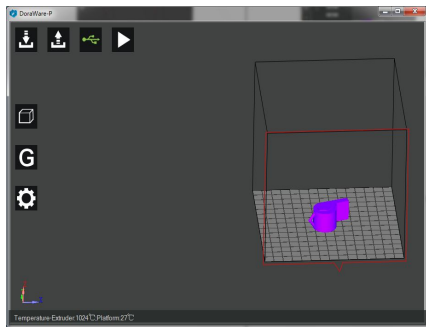

4.3.6.5 Click the model with the right mouse button, and the following menu pops out. Select "Land" and the model will descend to the center of the platform. Select "Reset" to restore the original state of the model. You can also select "Remove" to uninstall the model.

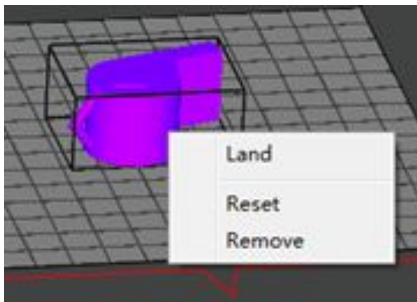

4.3.7 Model view display

4.3.7.1 After the model is selected, click the menu icon "View". The following figure is the model view display in terms of "Reset".

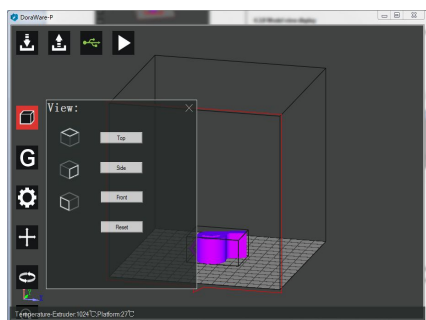

4.3.7.2 Click the menu icon "Top", the model will be displayed at the overlooking angle, as follows.

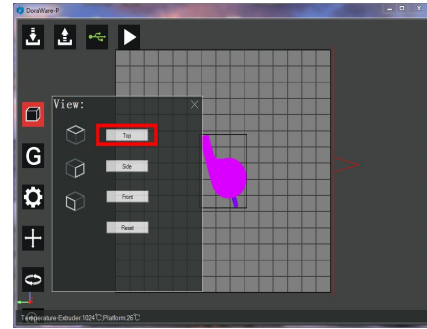

4.3.7.3 Click the menu icon "Side", the model will be displayed at the right viewing angle, as follows.

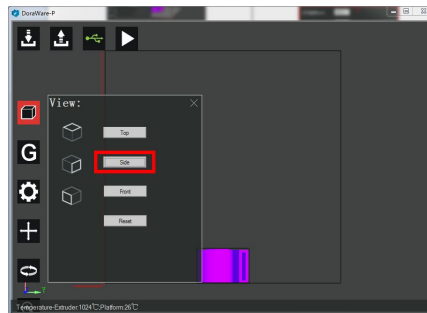

4.3.7.4 Click the menu icon "Front", and the model will be displayed as follows.

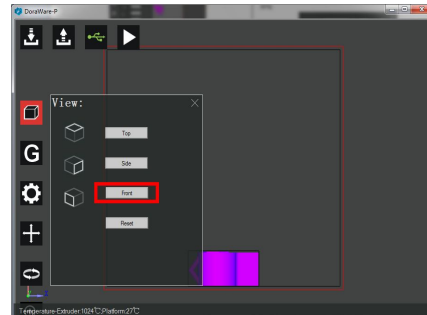

4.3.8 Print parameter settings

4.3.8.1 Click the icon "GCode" and the setting dialog pops out.

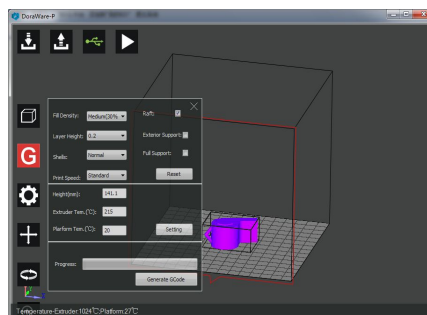

4.3.8.2 The dialog to generate GCode is divided into three parts, the column "1" is to set model parameters, the column "2" is to set IdeaWerk Plus parameters and the column "3" is to generate GCODE.

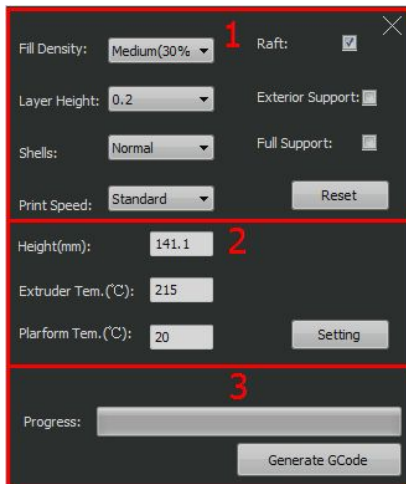

4.3.8.3 Model density refers to the filling density of the model, set by percentage. Click “▼” to select different densities. (The default is medium 30%)

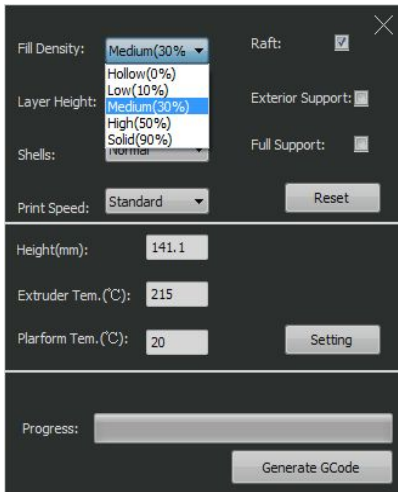

4.3.8.4 Different filling densities will affect the printing time. In the same model, the greater the density, the longer the duration of the printing, the more solid the model. Please select different density according to the actual needs as shown below.

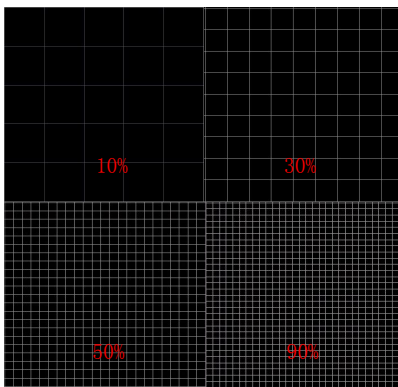

4.3.8.5 Layer thickness refers to the height of each layer of the model. Click “▼” to select 0.2 or 0.3mm, and the default is 0.2mm. The print time at the parameter of 0.3 will be shorter than 0.2, but the model’s surface is less accurate.

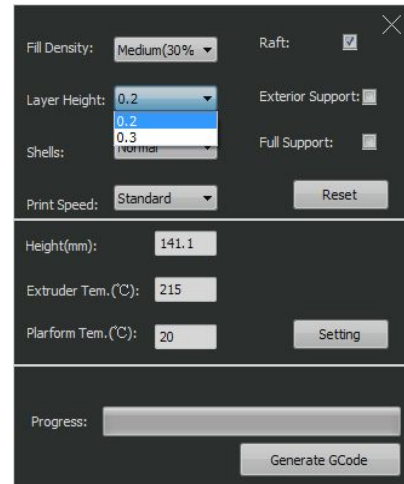

4.3.8.6 Case layers refer to the thickness of the model surface. Click “▼” to select different wall thickness, “Thin, Normal or Thick”.

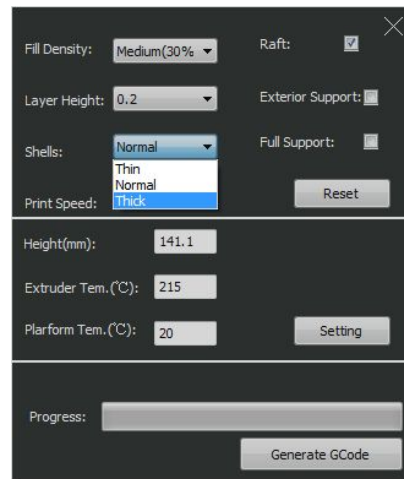

4.3.8.7 If the model is a cube, with the same filling (10%), the thickness of the red frame represents different effect of “Thin, Normal or Thick”, as shown below.

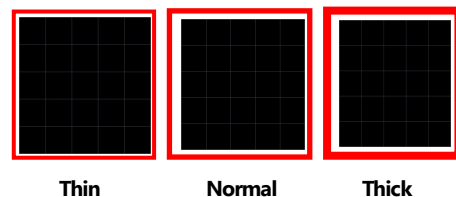

4.3.8.8 Speed means the movement speed of the model during the printing and the speed of the extruder. With different printing speeds, the model consumes different time. The higher the speed, the shorter the duration, the less accurate the model surface. Please select according to the actual situation. Click “▼” to select different speeds “slow, standard or fast”.

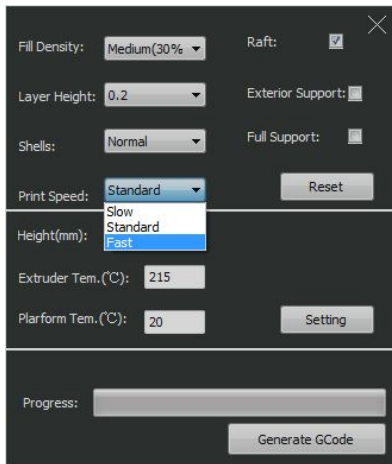

4.3.8.9 In order to make the model better fixed on the build plate, it is recommended to first print the bottom and then print the model on the bottom.

⚠ Notice: without the bottom printed, only smaller models can be printed, the platform shall be well adjusted and a layer of textured paper needs to be pasted.

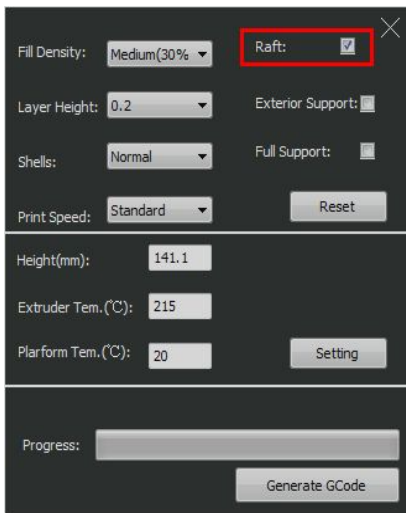

4.3.8.10 Some models require support to complete printing, including external support and overall support. External support refers to additional printing part added to support the overhanging part on the surface of the model. As shown below, the external support is needed between the animal's chin and the platform.

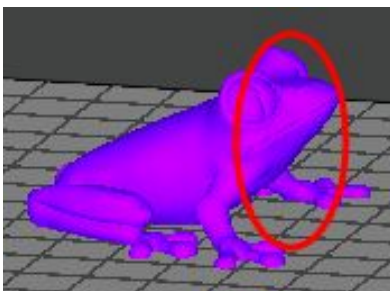

4.3.8.11 Overall support refers to both internal and external support of the model.

Version 001

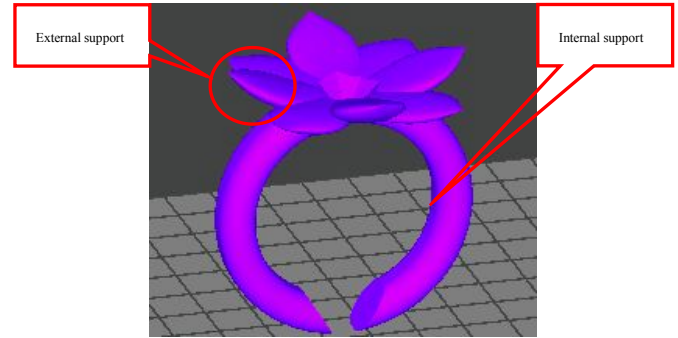

4.3.8.12 Structure of internal and external support of the model

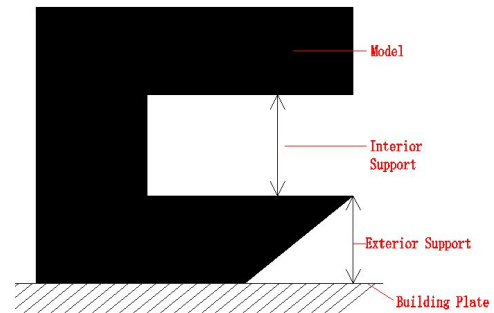

4.3.8.13 In print parameter settings, check Exterior support and Full support, as shown below.

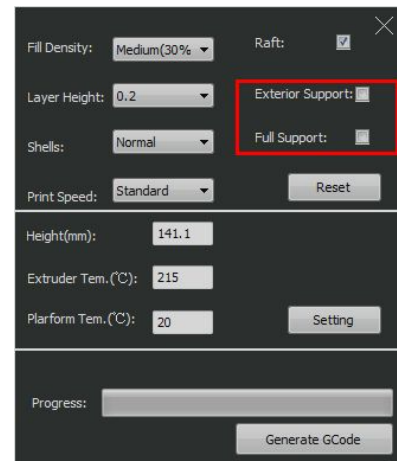

4.3.8.14 If some parameters are modified, but you want to use the original parameters, you can click "Reset" to restore the default settings, as shown below.

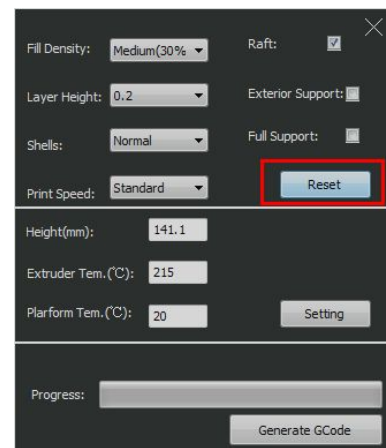

4.3.8.15 Set the print height: directly input Z-axis height in the dialog and

click "Setting". This value is height of the generated printing file which can also be set before IdeaWerk Plus connection.

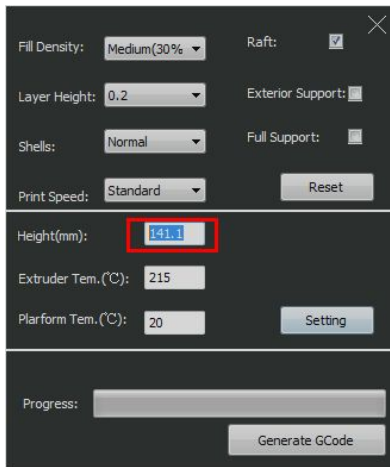

4.3.8.16 Set the nozzle temperature: directly input the temperature in the dialog box and click "Setting". For PLA material, the recommended temperature is 220-230 °C and for ABS material, the recommended temperature is 230-240 °C.

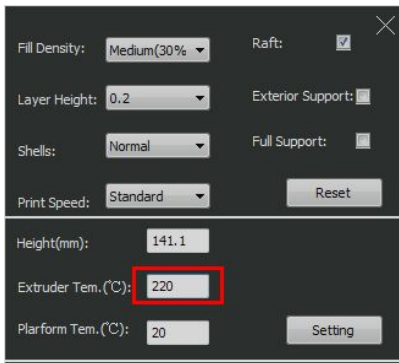

4.3.8.17 Set the platform temperature: directly input the temperature in the dialog box and click "Setting". For PLA material, the recommended temperature is 40 °C or below and for ABS material, the recommended temperature is 80-100 °C according to the size of the model.

⚠ Notice: the platform temperature cannot be set lower than the ambient temperature.

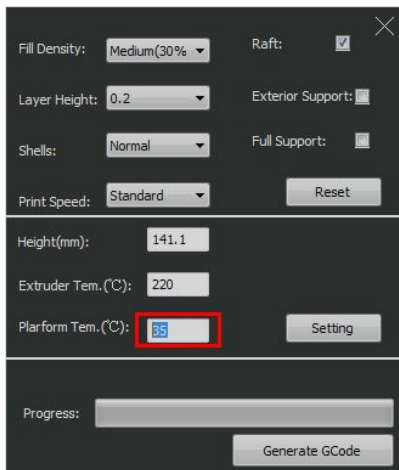

4.3.8.18 After the above parameters are set, click "Generate GCode".

Version 001

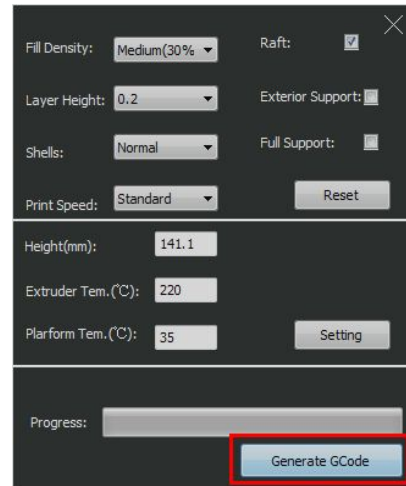

4.3.8.19 During GCODE generation, in case of improper parameter settings found, click "Cancel GCode", as shown below.

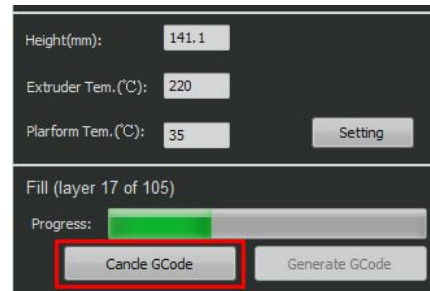

4.3.8.20 After GCODE is generated, the interface pops out as shown below, and click "OK".

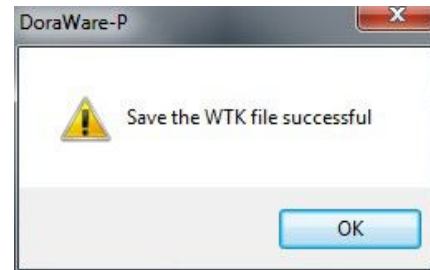

4.3.9 Control the printer

4.3.9.1 Click the icon of IdeaWerk Plus control, and the control interface pops out.

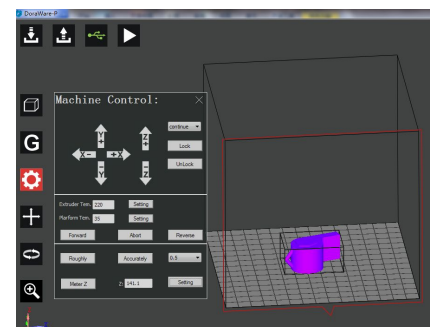

4.3.9.2 IdeaWerk Plus control includes three parts: movement control "1", temperature control "2" and Z-axis height setting "3", as shown below.

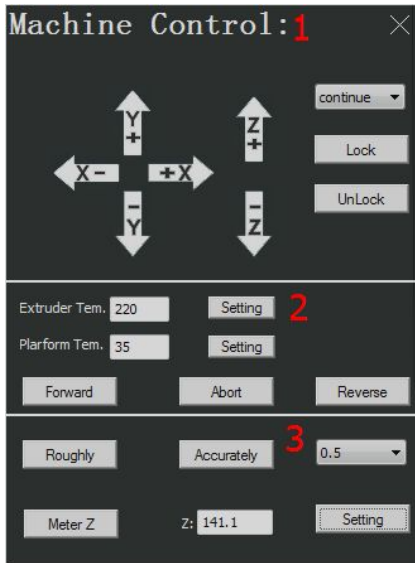

4.3.9.3 Click X/Y/Z, and the three axes of IdeaWerk Plus will move along the corresponding direction. Click the pull-down window “continue▼” to select the step length of single movement.

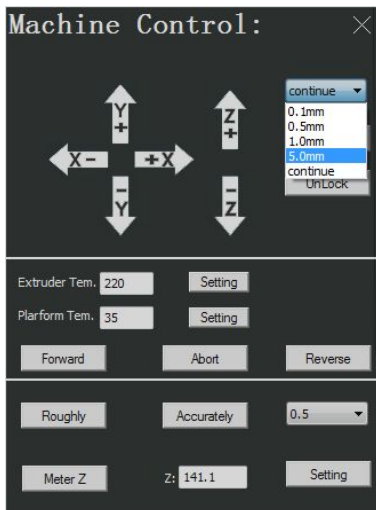

4.3.9.4 After movement to a position, to lock or unlock the motor, you can click “Lock” or “Unlock”.

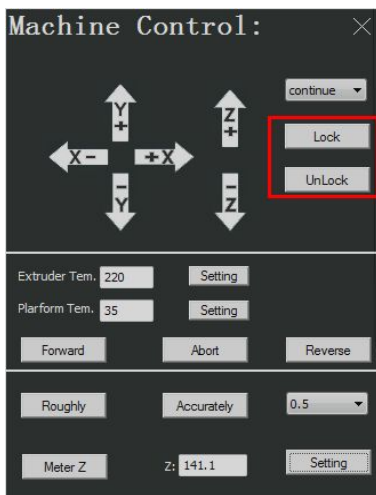

4.3.9.5 Set the nozzle temperature: input the target temperature and click “Setting”, and the nozzle begins heating. For PLA material, the Version 001

recommended temperature is 220-230 °C and for ABS material, the recommended temperature is 230-240 °C.

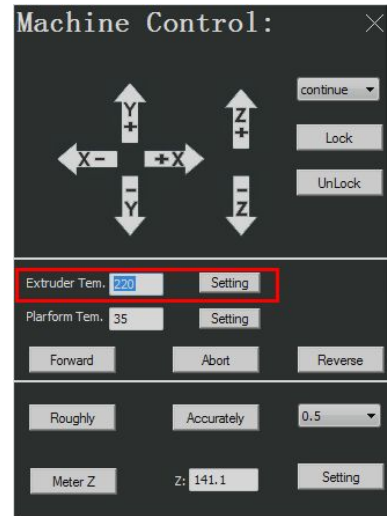

4.3.9.6 Set the platform temperature: directly input the target temperature and click “Setting”, and the platform begins heating.

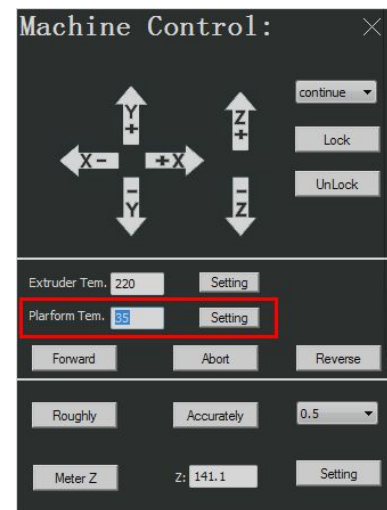

4.3.9.7 After the nozzle temperature reaches the set value, you can click “Forward/Abort/Reverse” to change the material or debug the nozzle.

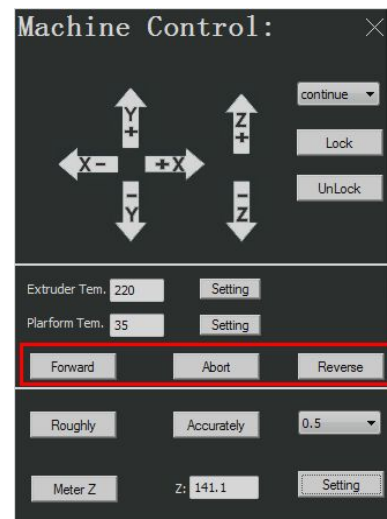

4.3.9.8 Before the nozzle temperature reaches the set value, you cannot

feed or return the material. If you click "Forward/Reverse", the following prompt box will pop out.

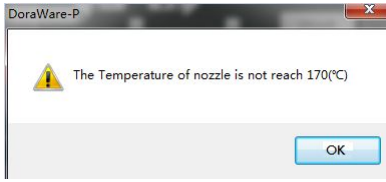

4.3.9.9 ⚠ Notice: difference between the temperature setting here and "Print parameter settings" in 4.3.8: The temperature setting here is to set the temperature of the IdeaWerk Plus when software is connected to the IdeaWerk Plus. If the temperature is set at 220 °C as GCODE file is generated but the temperature before printing is set at 230 °C, the printing is carried out at 230 °C. It is the same with the platform temperature setting. The temperature setting in 4.3.9.16 and 4.3.9.17 is to set the temperature as GCODE file is generated, which can be set before software is connected to the IdeaWerk Plus.

4.3.9.10 In the part of Z-axis height setting, click "Roughly", and Z-axis platform will automatically descend to the lowest point and then rise close the nozzle nozzles. At this time, according to the distance between the platform and the nozzle, click "▼" after "Accurately" to select the step length of single Z-axis movement. If "0.5" is selected for debugging of this IdeaWerk Plus, which is equal to clicking "Accurately", Z-axis moves 0.5mm upwards. The less the distance between the platform and the nozzle, the smaller the step length. If the platform touches the nozzle, choose a negative for the movement downwards, as shown below.

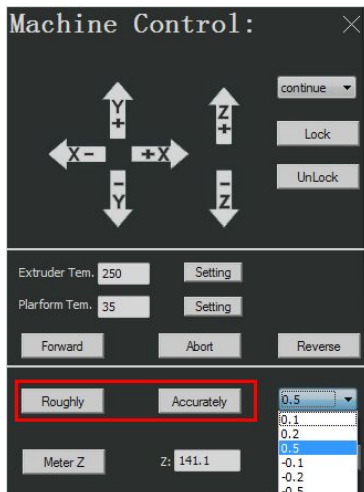

4.3.9.11 The precisely moving height of Z-axis platform, you can just put a card between the platform and the nozzle, as shown below.



4.3.9.12 Click "Meter Z", and the IdeaWerk Plus automatically starts measuring. You can see the increase of the figure in the dialog after "Z:". After the measuring is complete, click "Setting" to complete the measuring of Z-axis height, and following printing will be carried out in terms of this height.

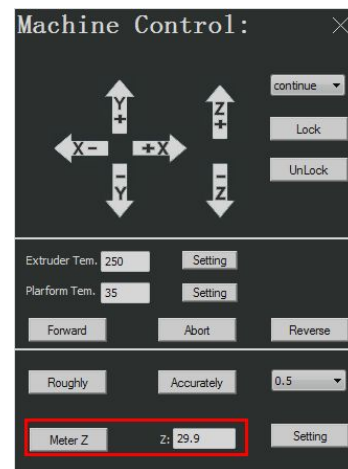

4.3.9.13 After a period of use or height of the platform needs to be fine-tuned, you can directly modify the figure in the dialog after "Z:", and click "Setting".

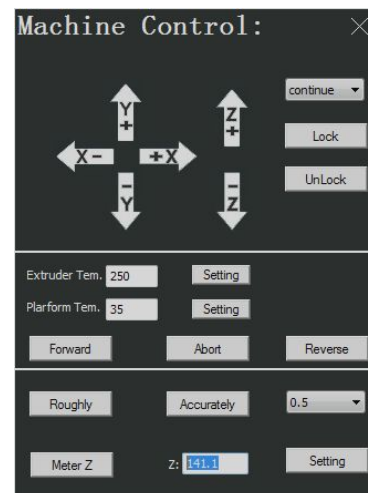

4.3.10 Model movement

4.3.10.1 Sometimes you need to move the model before printing. After the model is selected, click the menu icon of model movement on the left, and the interface pops out.

⚠ Notice: only after the model is selected, the menu icon of model movement can appear.

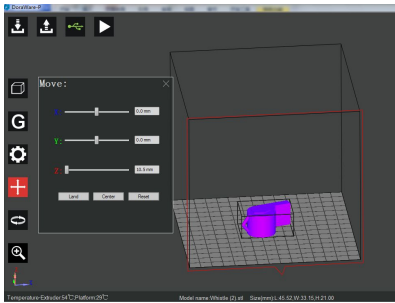

4.3.10.2 The imported model will be automatically placed in the center of the platform. You can move the slider in "X/Y/Z" with the mouse to change its position, and the model will move on the platform according to the distance the slider moves.

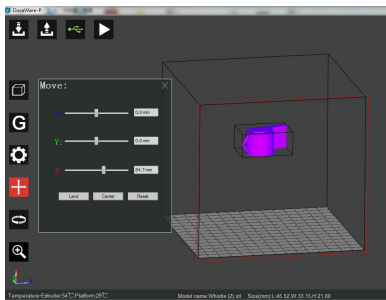

4.3.10.3 You can also directly input the moving distance in the slider dialog of "X/Y/Z". Notice: if the moving distance is beyond the maximum frame, the model will move to the position of the maximum frame, as shown below.

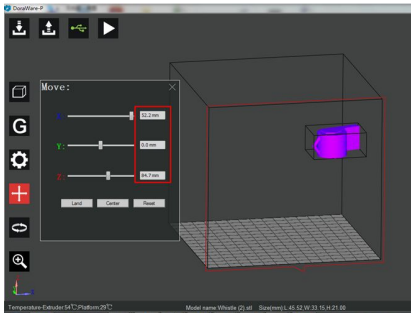

4.3.10.4 After the model is rotated, scaled or moved, if you want to move the model to the center of the platform, click "Land" and "center" or click "Reset" to return to the original state of model printing.

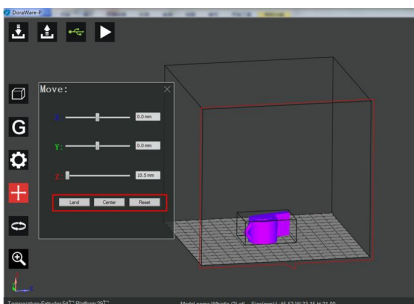

4.3.10.5 If you want to import multiple models or move one model, select the corresponding model with the left mouse button and then move it. ⚠ Notice: each time, only one model can be selected, multiple models
Version 001

cannot be selected or automatically arrange after import.

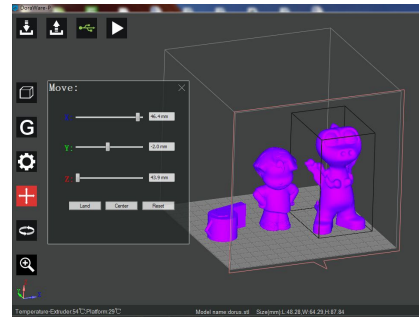

4.3.11 Model rotation

4.3.11.1 Select the model and click the left menu icon of model rotation.

⚠ Notice: the left menu icon of model rotation will not appear before the model is selected.

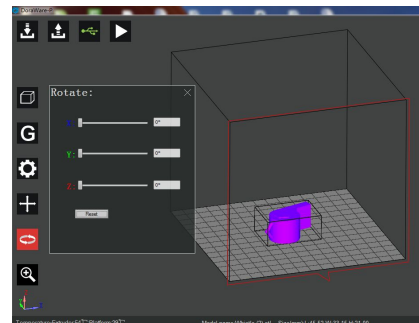

4.3.11.2 To rotate the model along the axial direction, move the slider on the corresponding axis with the mouse or directly input the rotation angle in the dialog, and click enter. The model's rotation angle will be displayed in the subsequent dialog. To return to the original state, click "Reset" to restore the original angle of the model.

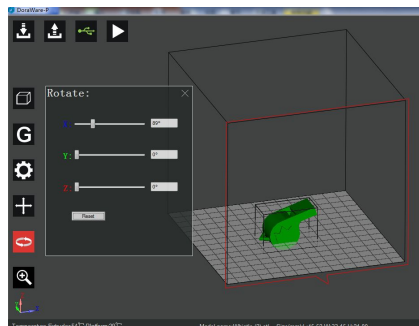

4.3.11.3 To operate one of several models, first select the model with the left mouse button, and then the model can be rotated, as shown below.

⚠ Notice: you can only rotate one model each time.

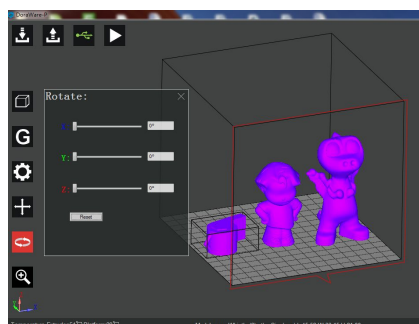

4.3.12 Model zoom

4.3.12.1 Select the model to be zoomed, click the Scale menu, and the following interface pops out.

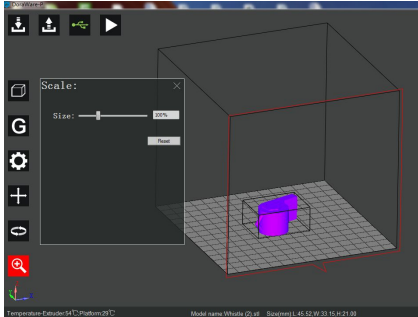

4.3.12.2 Move the slider with the mouse or input directly the zoom scale in the dialog.

⚠ Notice: The maximum size of zooming cannot be larger than the printing size.

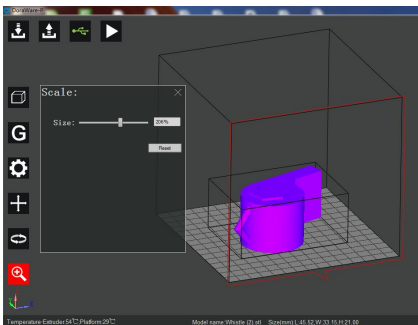

4.4 Print from PC

4.4.1 Software features are described above, this section takes the cube model for example to introduce the whole process of online printing. After connecting software to the IdeaWerk Plus, import the cube model, as shown below.

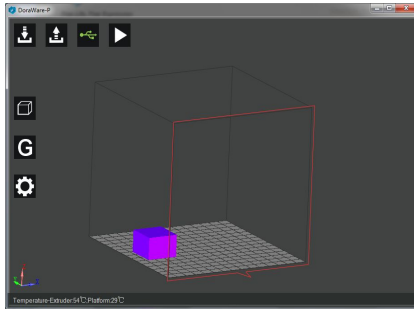

4.4.2 Select the model with the left mouse button, click the left menu button to move the model to the center of the platform, and you can click "center", as shown below.

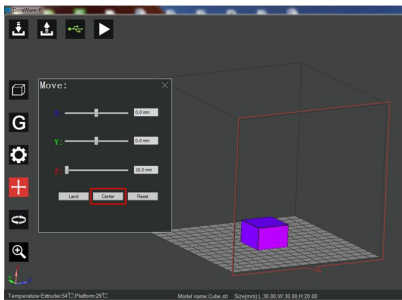

4.4.3 Click the left menu button to generate GCODE (PLA material used for printing), set the nozzle temperature at 220 °C and the platform temperature at 30 °C, and click "Setting", as shown below.

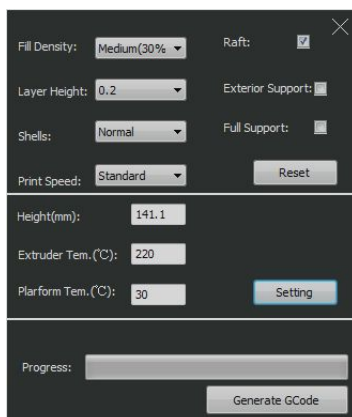

4.4.4 Other parameters are default settings. Click "Generate GCODE". After GCODE is generated, click "OK" to close the prompt box popping out.

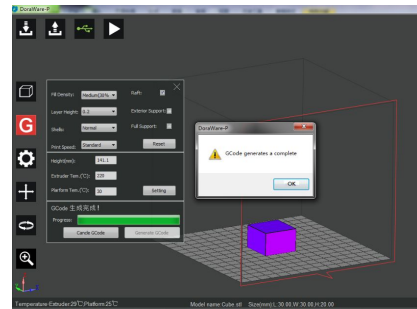

4.4.5 Click the button "Start Print", and the IdeaWerk Plus begins to work, as shown below.

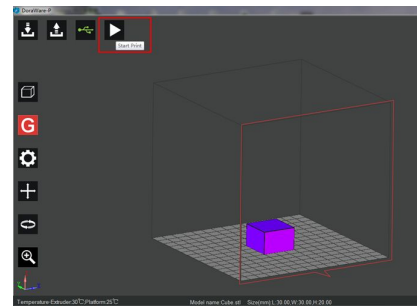

4.4.6 After model printing, the object is as shown below. Follow steps in 3.2.8-9 to remove the model.

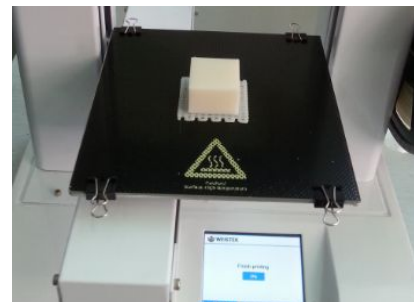

4.5 Print from PC notes

4.5.1 Turn off the computer's sleep mode before printing, otherwise the printing process will be interrupted.

4.5.2 Before removal of the model, first remove the panel of the build plate. Direct removal of the model may bend the build plate, resulting in change in height of the nozzle and the build plate and affecting the printing next time.



V. After-sale service contact

Each device is labeled with a serial number at the back. In case of any unusual circumstance in the use, please take pictures or video and send them together with the bar code to the local dealer or service personnel.

Thank you for choosing IdeaWerk Plus 3D printer and your support to Weistek!

Tel: 86-755-8669 9130 (EXT 623)

Email: service@weistek.net

Annex 1 Maintenance

Proper usage and maintenance can reduce machine faults and prolong its service life. Followings are maintenance of the key part of the printer.

I. Maintenance of the printing platform

1. Do not directly remove the model from the platform. First remove the heating panel and then separate the model from the panel, for the frequent separation of the model on the platform tends to cause uneven or deformed platform, affecting or voiding the printing. Refer to the 3.2.8-3.2.9 for specific operation.
2. After the model is removed, clean the aluminum plate fixing the panel and material residue to avoid uneven panel surface affecting the printing next time.
3. The panel after repeated use may have slight distortion. Fix the cleaned panel on the platform in time. If there is concave or convex in the middle of the panel, put the convex side to the contact surface of the aluminum plate, and fixed with clamps. In case of serious deformation, the platform can be appropriately heated, and it will restore the original state.

II. Maintenance of the nozzle

1. After the printing, if the next model is not printed for a short period of time, it is recommended to return the filament in the nozzle and set the extruder temperature below room temperature. Because the melting filament at high temperature will corrode the metal part inside the nozzle. In case of long-time heating without melted material returned, the material after carbonization tends to clog the nozzle and even damage it.
2. It is recommended to clean your Ideawerk Plus after printing to keep the nozzle clean to avoid clogging. In the printing process, there will be a little material left in the nozzle, especially ABS material. If your Ideawerk Plus is not cleaned for a long time, residual material will cover the entire nozzle. After heating at high temperature for a long time, black dirt can be seen and even affect printing quality. Cleaning methods are as follows: after the model is printed, the nozzle temperature is still high, use forceps or diagonal pliers to hold a piece of clean cloth or soft paper towel to wipe repeatedly the place with residue till it is clean. If the nozzle temperature falls, it can be cleaned after re-heated to 220 °C.

 Notice: at this point, the temperature is high. Wear protective gloves to avoid burns!

III. Maintenance of the touch screen

1. The touch screen is a main part of your Ideawerk Plus to show the information and control your Ideawerk Plus, so do not damage it with sharp

stuff and make it impossible to use.

2. Turn off your Ideawerk Plus power before cleaning the touch screen. Use microfiber cloth or eyeglass cleaning cloth to gently wipe the screen. In case of severe stains, use clean cloth with distilled water to clean. Do not use much force. Dry it naturally after cleaning.

Annex 2 Tips and Tricks

1. A flat printing platform is one of key factors that affect success of model printing. For a larger model, warpage and deformation tend to occur, especially for ABS material that is more evident. It indicates uneven printing platform, which should be calibrated before printing.
2. Z-axis height setting will affect separating the model and the panel. If the printed model sticks tight to the panel and it is difficult to separate them, the Z-axis height is set too large, which should be reduced; if the printed model is easy to separate from the panel or the model has warping edge or even fall off during the printing of a large size, the Z-axis height is set too small, which can be increased appropriately. An appropriate Z-axis height can be determined by tests for several times.
3. Since ABS material has high shrinkage, when it is used for printing, your Ideawerk Plus should be placed in a slightly higher temperature environment to avoid direct strong air flow to your Ideawerk Plus caused by the air conditioner or the fan. Suggest to set the platform temperature at 80 °C and above.
4. After GCODE is generated, if the model is printed with PLA materials subject to the set parameters but you want to use ABS material, or the Z-axis height is modified, there are two ways for you to directly modify the print parameters without generating the GCODE file again: one is print from PC. Click the menu "Generate GCODE" to reset the nozzle temperature, the platform temperature and the printing height, and it will be printed according to new parameters; the other is print from USB flash disk. Tap the interface "Move" on the touch screen to reset the temperature of the nozzle and the platform.  Notice: the modified temperature value is only valid this time, which needs to be reset for the printing of the same model next time. Z-axis height can be reset in the interface "Advanced".
5. For ABS material, the bottom or the support should be removed as the model maintains a high temperature.
6. When the printing starts, the nozzle will first extrude a little material to test whether the extrusion is normal. Then please use forceps to take away the extruded material to prevent it from sticking to the nozzle during printing and affecting the printing effect.