

120 x 120 x 25 mm

AC Axial Fans

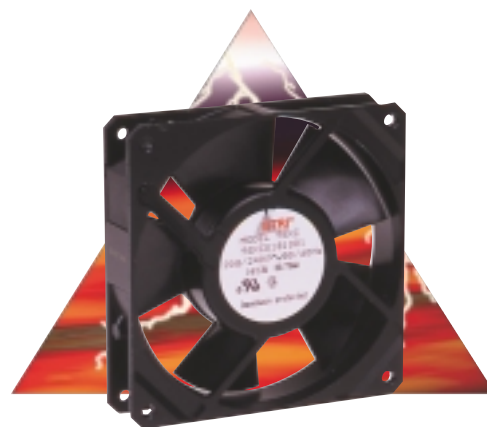
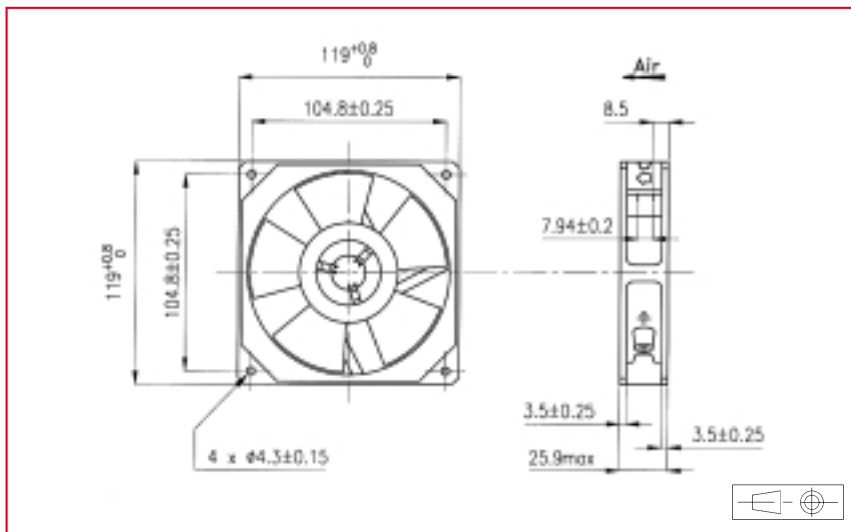

Approvals

See selection guide pages 15 to 26
GAMT 1 listed

Life expectancy

L-10 LIFE AT 40°C:
80 000 hours (ball bearings)
50 000 hours (sleeve bearings)
For more details, see page 14

AC Motor

Electrical protection: impedance protected
Housing material: zamak
Impeller material: plastic UL 94 VO
Weight: 0,465 kg

Available with:

- speed sensor

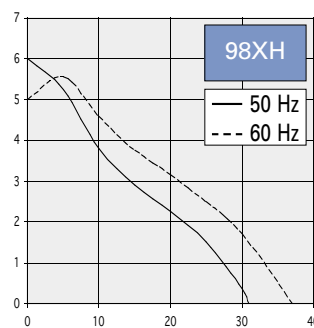
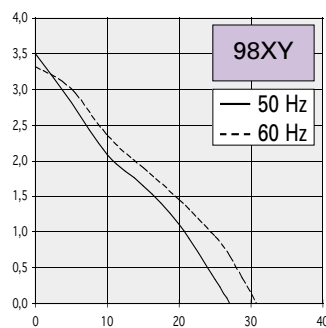
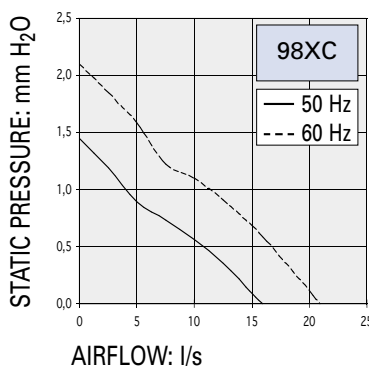

Part number	Nominal voltage	Airflow	Noise level	Nominal speed	Frequency	Phases	Capacitor	Input power	Nominal current	Starting current	Bearing system		Connection type		Operating temperature	
	V	l/s	dB(A)	RPM	Hz		µF	W	mA	mA	Ball	Sleeve	Leads	Terminals	Min. °C	Max. °C
98XC0182000	115	16	32	1300	50	1		12	130	150	X			X	-10	70
		21	35	1700	60	1		10	110	130	X			X	-10	70
98XC0181000	208-240	16	32	1300	50	1		14	80	90	X			X	-10	70
		21	35	1700	60	1		12	70	75	X			X	-10	70
98XY0182000	115	27	36	2100	50	1		10	120	140	X			X	-10	70
		31	38	2400	60	1		9	100	120	X			X	-10	70
98XY0181000	208-240	27	36	2100	50	1		12	65	80	X			X	-10	70
		31	38	2400	60	1		10	55	65	X			X	-10	70
98XH0182000	115	31	41	2555	50	1		13	135	200	X			X	-10	70
		37	44	3000	60	1		11	110	180	X			X	-10	70
98XH0181000	208-240	31	41	2550	50	1		15	80	100	X			X	-10	70
		37	44	3000	60	1		13	65	90	X			X	-10	70

Additional versions:

Other speeds - salt spray protected - shock and vibration protected - marine specifications - wide temperature range - sleeve bearings

Accessories:

See pages: 148, 150, 151, 152, 153, 154, 157, 161 and 162

Non contractual document. Specifications are subject to change without prior notice. Pictures for information only. Edition N°2 / 01.