

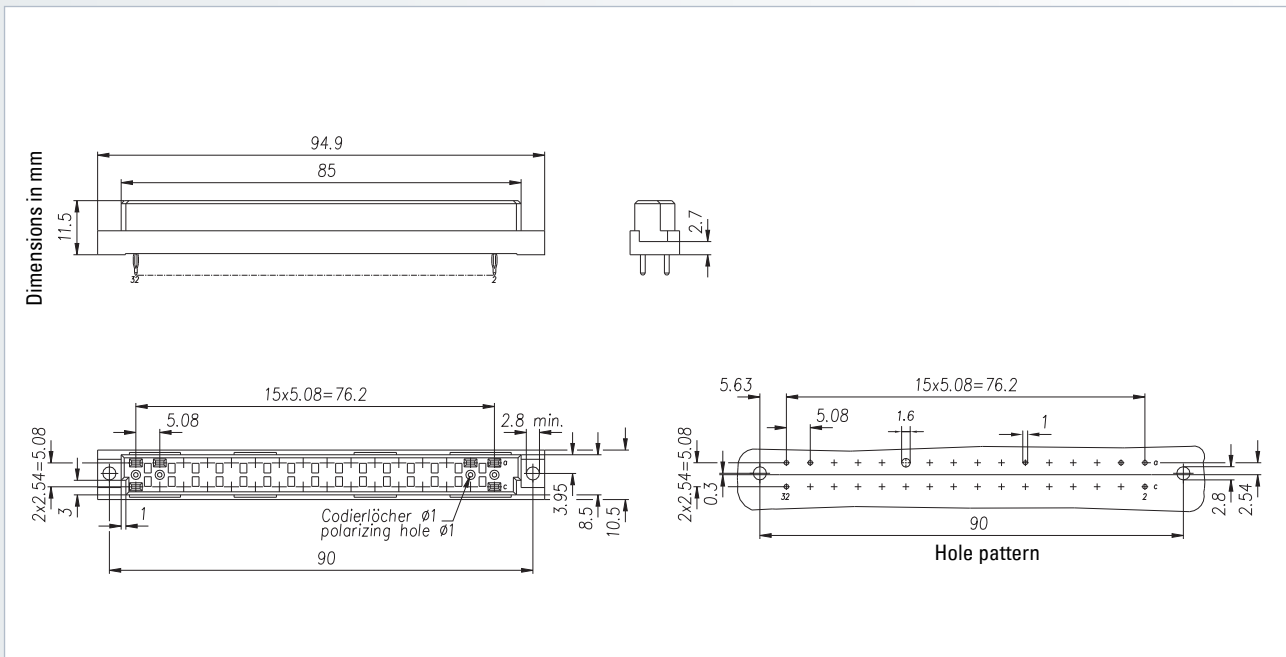



Connectors according to DIN 41612 / IEC 60603-2

Type D

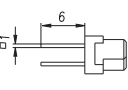
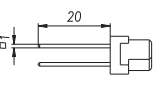

Female connector

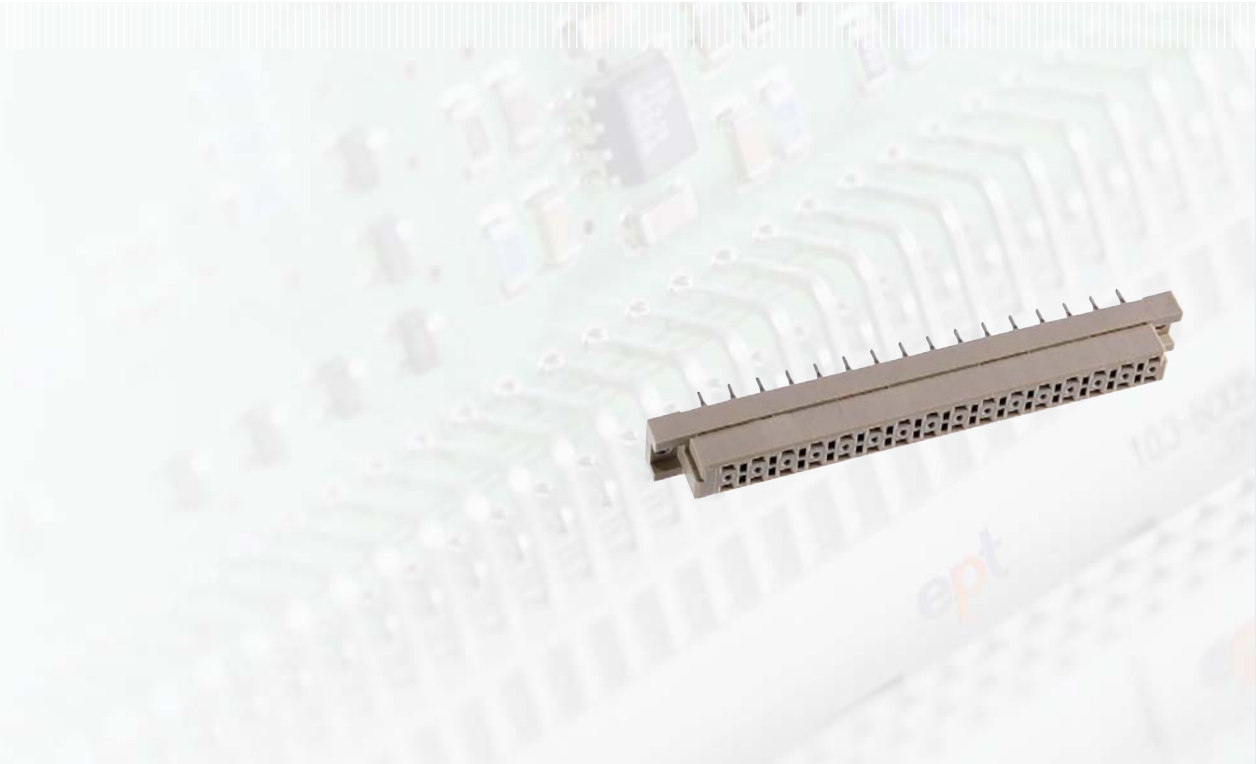

No. of contacts	Contact arrangement	Press-fit technology – Performance level II		
		Termination length		
				
Part number				
32		106-60084	106-60064	106-60065

Accessories	On request	Options
<ul style="list-style-type: none"> – Press-fit tool (see page 208) – Support tool (see page 209) – Coding accessories (see page 160) 	<ul style="list-style-type: none"> – Performance levels I + III or customer-specific – Special contact length 	<ul style="list-style-type: none"> – Without flange – Contact arrangement (see page 162)

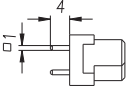
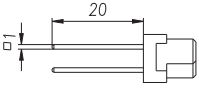
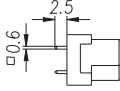
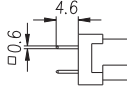

No. of contacts	Contact arrangement	Solder technology – Performance level II				
		Termination length				
						
Part number						
32		106-40064	106-40065	106-40084	106-40075	106-40066

<p>Accessories</p> <ul style="list-style-type: none"> – Coding accessories (see page 160) 	<p>On request</p> <ul style="list-style-type: none"> – Performance levels I + III or customer-specific – Special contact length – Also in THTR 	<p>Options</p> <ul style="list-style-type: none"> – Board lock (see page 159) – Contact arrangement (see page 162)
---	--	---