

THE PRODUCT

The OKW DESK CASE range covers many different fields of application. Choose a case that will fully meet your specific requirements in terms of size and tilt of the control panel.

Front panel versions are available for the installation of complete prefabricated electronics units.

YOUR ADVANTAGE

Various angles of inclination for the control panel, depending on requirements. Practical for operating and reading off the unit.

Suitable for numeric keypads and membrane keyboards.

Prepared for the assembly of eurocards 100 x 160 (138/190/190F/190H).

Versions with ample space for large assemblies.

Raised section giving space for easy installation of cable grommets and plug connectors (220, COMBI DESK CASE F/H).

Version with attachment for digital readouts, measuring equipment, encoders etc. (COMBI DESK CASE H).

APPLICATIONS

Systems for data collection on the job and machines. Communications equipment. Access and security controls, data systems engineering.

Medical and laboratory technologies.

Industrial control systems.

Point-of-sale.

PROTECTION CLASS < IP 40

MAX. SIZE OF PCB

DESK CASE/ COMBI-DESK	W x D in mm	
	bottom part	top part
138	118 x 180	127 x 175
190...	180 x 118	175 x 127
220	210 x 147	—
F/H	210 x 196	—

(cutouts for pillars not taken into consideration)



DESK CASES

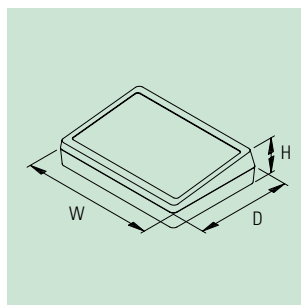
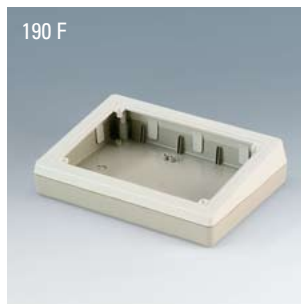

ENCLOSURES

DESK CASE	Outside dim. in mm			Equipment (dim. in mm)		Colour bottom part/top part	Material	Part-No.
	W	D	H	front panel	max. dim. keypad			
138	138	190	54/32	–	119.70 x 166.20 (r = 4)	off-white	ABS (UL 94 HB)	A 05 14 007
	138	190	54/32	–	119.70 x 166.20 (r = 4)	black	ABS (UL 94 HB)	A 05 14 009
190	190	138	47/32	–	171.50 x 116.10 (r = 4)	off-white	ABS (UL 94 HB)	A 05 19 007
	190	138	47/32	–	171.50 x 116.10 (r = 4)	black	ABS (UL 94 HB)	A 05 19 009
190 F	190	138	47/31.5	• (accessory)	–	pebble grey/off-white	ABS (UL 94 HB)	A 90 86 265
190 H	190	138	70/54.5	• (accessory)	–	pebble grey/off-white	ABS (UL 94 HB)	A 90 86 365
220	220	156	100/52	• (accessory)	–	pebble grey/off-white	ABS (UL 94 HB)	A 90 82 065

COMBI DESK CASE	Outside dim. in mm			Equipment		Colour bottom/top part, attachm.	Material	Part-No.
	W	D	H	front panel/s	attachment			
F	228	216	76/50	• (accessory)	–	pebble grey/off-white	ABS (UL 94 HB)	A 90 84 165
H	228	216	126/50	• (accessory)	• (clip into)	pebble grey/off-white	ABS (UL 94 HB)	A 90 85 165

ACCESSORIES (wall suspension element for DESK CASES 138/190 see accessories page 103)

Article	For enclosure	Version / Application	Part-No.
	190 F/H	matt anodised aluminium 161.5 x 106 x 1.5 mm (screws supplied with case)	A 91 86 001
	220	matt anodised aluminium 205.5 x 129.4 x 1.5 mm (screws supplied with case)	A 91 80 001
	F/H	matt anodised aluminium 200 x 130 x 1.5 mm (screws supplied with case)	A 91 84 001
	H (attachment)	matt anodised aluminium 200 x 35 x 1.5 mm (screws supplied with case)	A 91 85 001

DATEC-KEYBOARD

The DATEC-KEYBOARD represents an almost indestructible case system for stationary data collection. The double-walled case construction provides the necessary stability for applications in rough conditions.

Flat areas for individual application and cutouts. Working without getting tired. Ergonomic design. The standard feet can be adjusted to different inclination angles (included). Holes on the bottom side of the cases allow direct mounting to a wall or machinery.



ENCLOSURES

DATEC-KEYBOARD	Outside dim. in mm			Equipment (dim. in mm) max. dim. keypad	feet	Material	Part-No.	
	W	D	H				off-white	black
S	340	240	40	309.20 x 165.40	•	ABS (UL 94 HB)	A 05 34 107	A 05 34 109
L	490	240	40	459.00 x 165.40	•	ABS (UL 94 HB)	A 05 49 107	A 05 49 109

ACCESSORIES

Article	Version / Application	Part-No.	
		S	L
Sealing kit	for sealing up to IP 65 , 1 O-ring for the case	A 91 34 001	A 91 49 001

KEYBOARD HOUSINGS

These KEYBOARD HOUSINGS have been developed according to ergonomic guidelines for VDU work stations. They are flat and practical, thus permitting pleasant handling as control units.

With predetermined openings for round cables with traction discharge, flange socket and 15-channel subminiature plug. Working without getting tired. Ergonomic design. With/without deposit groove. Providing more space for additional key blocks, function keys, digital readouts.



ENCLOSURES

KEYBOARD HOUSING	Outside dim. in mm			Version / Equipment (dim. in mm)		Material	Part-No. off-white
	W	D	H	with deposit groove			
370	370	185	37.5	I	338 x 25	ABS (UL 94 HB)	A 05 37 407
	370	185	37.5	II	–	ABS (UL 94 HB)	A 05 37 007