

Display Elektronik GmbH

# DATA SHEET

**TFT MODULE**

**DEM 240320H TMH-PW-N  
(A-TOUCH)**

**3,2" TFT with Touch-Panel**

*Product Specification*

*Ver.: 0*

27.05.2011

Revise Records

Rev.	Date	Contents	Written	Approved
0	27.05.2011	Preliminary Specification	MH	MH

Special Notes

Note1.	
Note2.	
Note3.	
Note4.	
Note5.	

## **CONTENT**

- 1. LCM DRAWING**
- 2. GENERAL DESCRIPTION**
- 3. MECHANICAL SPECIFICATIONS**
- 4. ELECTRO-OPTICAL CHARACTERISTICS**
- 5. BLOCK DIAGRAM**
- 6. ELECTRONIC CHARACTERISTICS**
- 7. PINS DESCRIPTION**
- 8. INSTRUCTION DESCRIPTION**
- 9. BACKLIGHT PARAMETERS**
- 10. PRODUCT QUALITY & RELIABILITY**
- 11. PRECAUTIONS IN USING**
- 12. APPLICATION**

1. LCM DRAWING

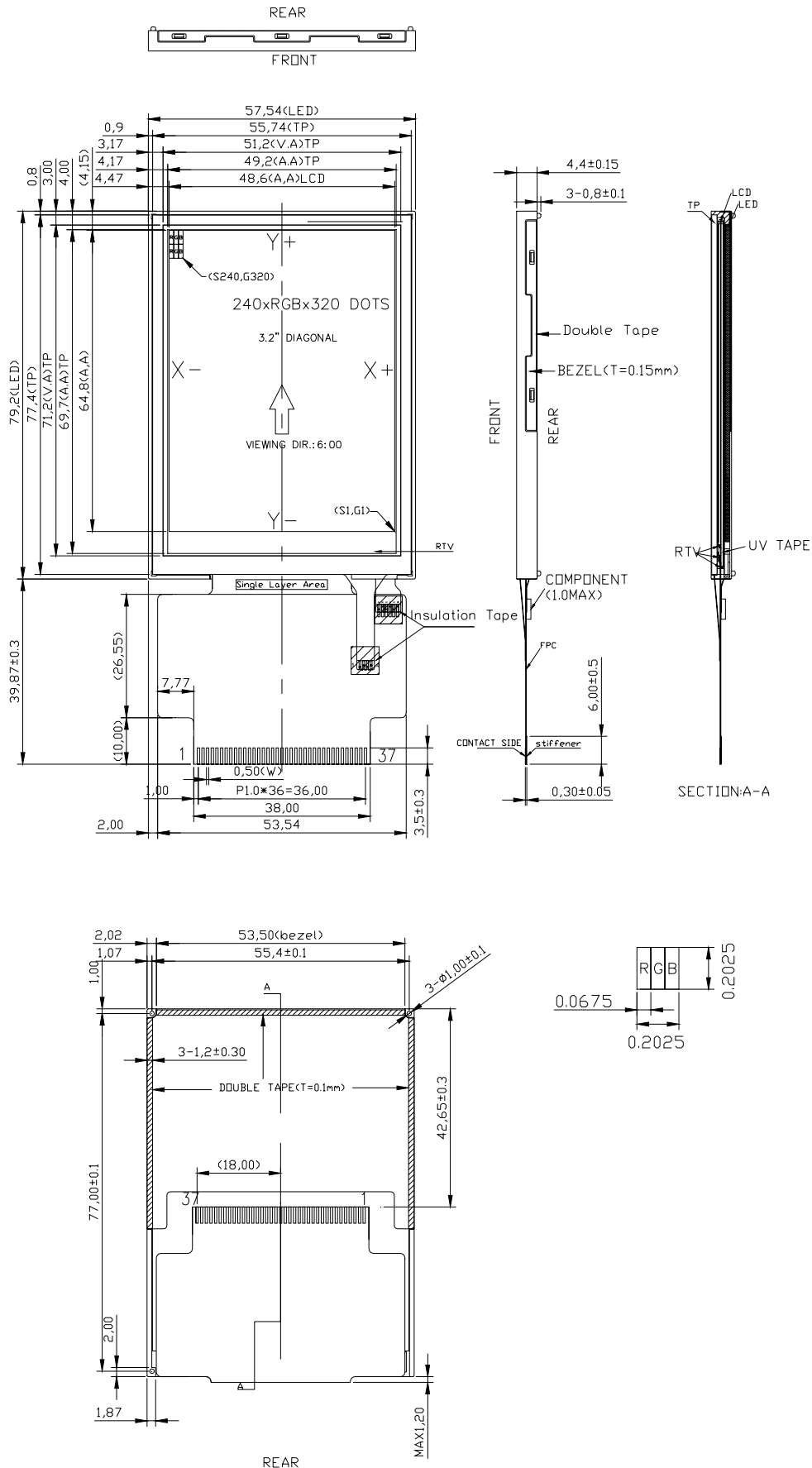

**2. GENERAL DESCRIPTION**

MAIN TECHNICS :	TFT TRANSMISSIVE NEGATIVE
DISPLAY CONTENT :	GRAPHIC
DISPLAY TYPE :	262k-COLORS
DRIVER METHOD :	1/320 DUTY
VIEWING DIRECTION :	6:00
CONTROLLER:	HX8347-A (HIMAX)
BACKLIGHT :	LED, LIGHTGUIDE, WHITE
OPEATING TEMPERATURE :	-20°C to +70°C
STORAGE TEMPERATURE :	-30°C to +80°C
INTERFACE:	80-SYSTEM, 16-BIT
REFERENCE DOCUMENTS :	HX8347-A datasheet

**3. MECHANICAL SPECIFICATIONS**

<b>ITEM</b>	<b>CONTENT</b>	<b>UNIT</b>
<b>PIXEL'S NUMBER</b>	<b>240 x RGB x 320</b>	<b>PIXEL</b>
<b>MODULE DIMENSION</b>	<b>57.54 x 119.07 x 5.20</b>	<b>mm</b>
<b>ACTIVE AREA</b>	<b>48.60 x 64.80</b>	<b>mm</b>
<b>PIXEL SIZE</b>	<b>0.2025 x 0.2025</b>	<b>mm</b>

## 4. ELECTRO-OPTICAL CHARACTERISTICS

### ELECTRICAL SPECIFICATION

Item	Symbol	Specification			Unit
		Min.	Typ	Max.	
TFT gate on voltage	VGH	-	15	-	V
TFT gate off voltage	VGL	-	-8	-	V
TFT common electrode voltage	VcomH	2.5	-	4.5	V
	VcomL	-2.0	-	0	

Note: (1) Vcom must be adjusted to optimize display quality: cross talk, contrast ratio and etc.

(2) VGH is TFT gate operating voltage

(3) VGL is TFT gate operating voltage

The storage capacitance structure of this product is Cst(Storage on Common).

The low voltage level of VGL signal must be fluctuated with same phase as Vcom, in case of Storage on Gate structure.

(4) Environmental condition:  $25 \pm 5^\circ\text{C}$

Optical specifications(light source: C light,using CMO TN LC+Polarizer,reference only)

Item	Symbol	Conditions	Specifications			Unit	Note	
			Min.	Typ.	Max.			
Transmittance	T%	Viewing normal angle $\theta_x = \theta_y = 0^\circ$		7.4		%	All left side data are based on CMO's following condition – Type 766 NTSC: 60% LC:5091 Light : C light (Machine:BM5A) Normal Polarizer Without DBEF	
Contrast Ratio	CR		150	250	-	-		
Response Time	$T_R$		NA	15	30	ms		
	$T_F$		NA	35	50	ms		
Chromaticity	Red		$X_R$	0.606	0.636	0.666		
			$Y_R$	0.298	0.328	0.358		
	Green		$X_G$	0.270	0.300	0.330		
			$Y_G$	0.549	0.579	0.609		
	Blue		$X_B$	0.102	0.132	0.162		
			$Y_B$	0.107	0.137	0.167		
White	$X_W$	0.272	0.302	0.332				
	$Y_W$	0.316	0.346	0.376				
Viewing Angle	Hor.	$\theta_{x+}$		45	-	deg.		
		$\theta_{x-}$		45	-			
	Ver.	$\theta_{y+}$		35	-			
		$\theta_{y-}$		15	-			

\*Note (1) Definition of Contrast Ratio (CR):

The contrast ratio can be calculated by the following expression.

$$\text{Contrast Ratio (CR)} = L_{63} / L_0$$

L63: Luminance of gray level 63

L0: Luminance of gray level 0

$$CR = CR(10)$$

CR (X) is corresponding to the Contrast Ratio of the point X at Figure in Note (6).

\*Note (2) Definition of Response Time (TR, TF):

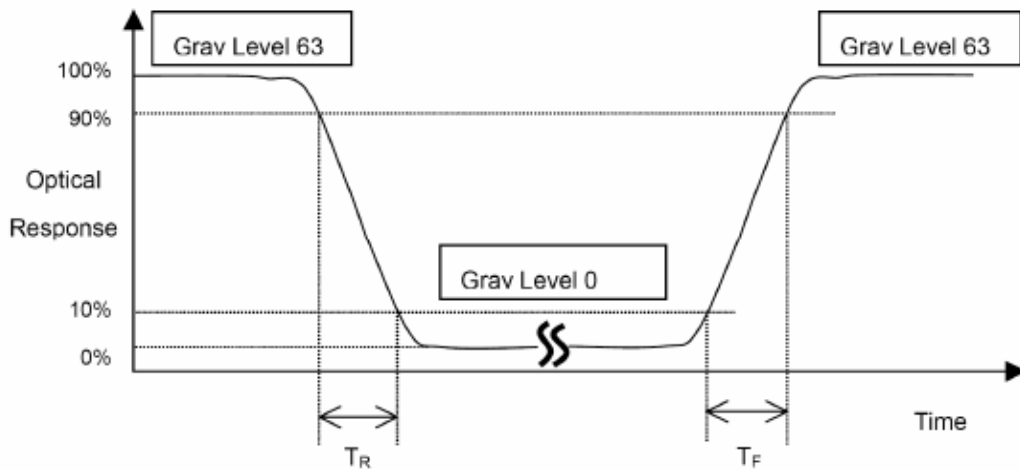

\*Note(3) Definition of Viewing Angle

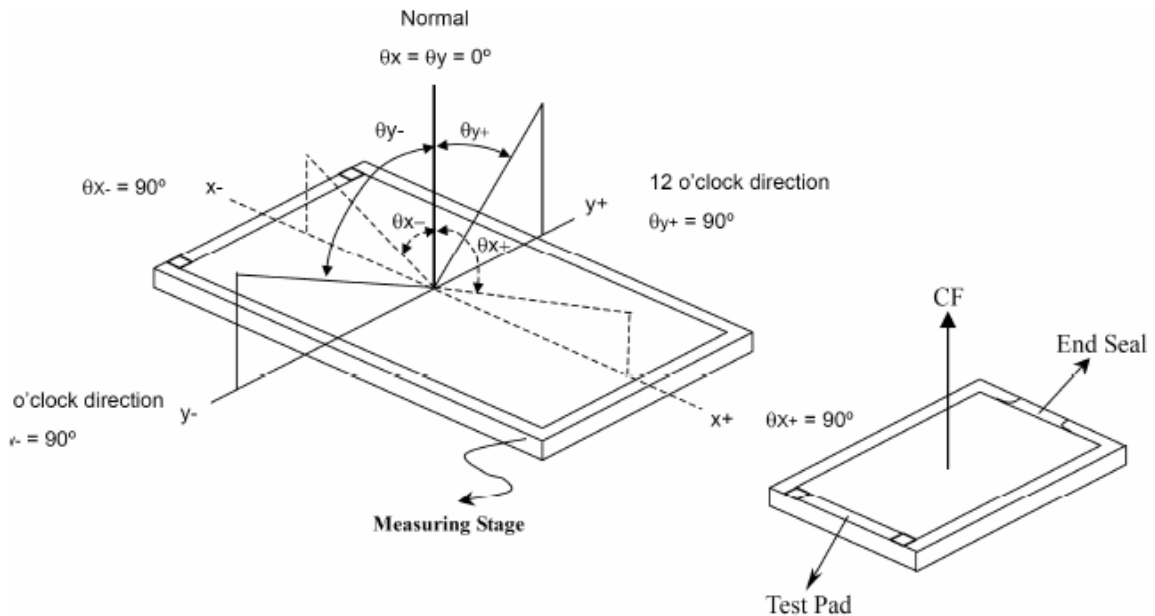

\*\*\* The above "Viewing Angle" is the measuring position with Largest Contrast Ratio; not for good image quality. View Direction for good image quality is 6 O'clock. Module maker can increase the "Viewing Angle" by applying Wide View Film.

**\*Note (4) Measurement Set-Up:**

The LCD module should be stabilized at a given temperature for 20 minutes to avoid abrupt temperature change during measuring. In order to stabilize the luminance, the measurement should be executed after lighting Backlight for 20 minutes in a windless room.

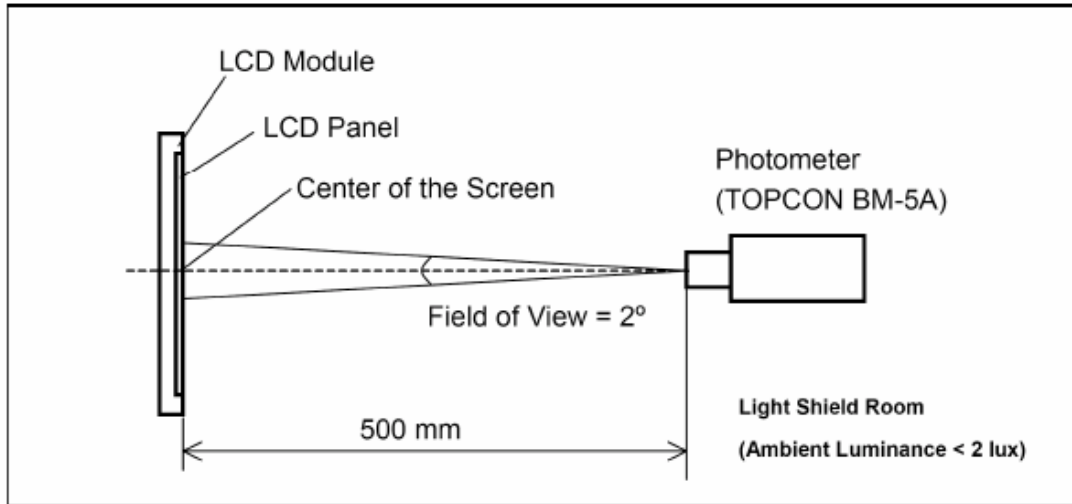

**\*Note (5)**

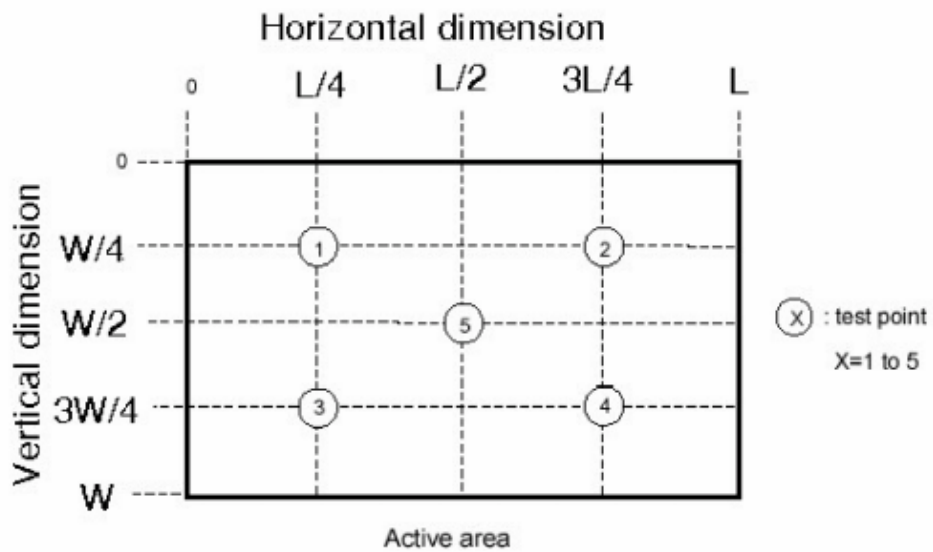



**5. BLOCK DIAGRAM**

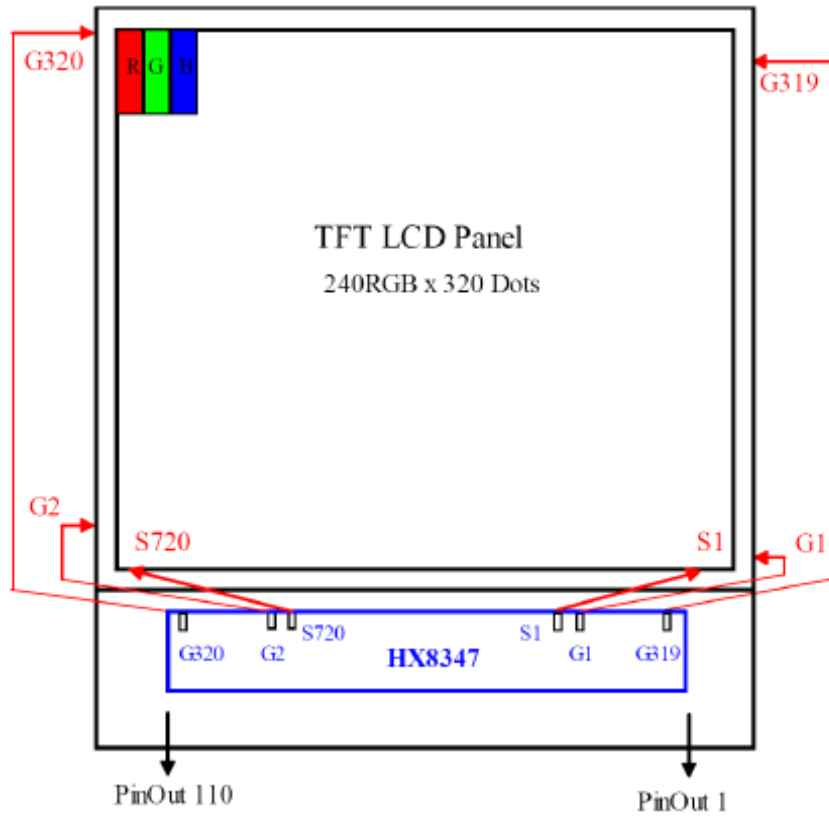

## 6. ELECTRONIC CHARACTERISTICS

### 6.1 MAXIMUM VALUES

Item	Symbol	Value	Unit	
Supply Voltage (1)	IOVcc	-0.3 ~ +4.6	V	
Supply Voltage (2)	Vci	-0.3 ~ +4.6	V	
Supply Voltage (3)	DDVDH	-0.3 ~ +9	V	
Supply Voltage (4)	VCL	-4.6 ~ +0.3	V	
Supply Voltage (5)	VGH	-0.3 ~ +18.5	V	
Supply Voltage (6)	VGL	-18.5 ~ +0.3	V	
Input Voltage Range	VIN	-0.3 ~ VCI+0.3	V	
Operating Temperature	Top	-20	+70	°C
Storage Temperature	Tst	-30	+80	°C

### 6.2 DC CHARACTERISTICS

Item	Symbol	Unit	Test Condition	Min.	Typ.	Max.	Note
Input high voltage	V <sub>IH</sub>	V	IOVcc= 1.65 ~ 3.3V	0.8xIOVcc	-	IOVcc	-
Input low voltage	V <sub>IL</sub>	V	IOVcc= 1.65 ~ 3.3V	-0.3V	-	0.2xIOVcc	-
Output high voltage(1) (D0-17 Pins)	V <sub>OH1</sub>	V	I <sub>OH</sub> = -0.1 mA	0.8xIOVcc	-	-	-
Output low voltage (D0-17 Pins)	V <sub>OL1</sub>	V	IOVcc= 1.65 ~ 3.3V I <sub>OL</sub> = 0.1mA	-	-	0.2xIOVcc	-
I/O leakage current	I <sub>LI</sub>	μA	Vin = 0 ~ Vcc	-1	-	1	-
Current consumption during normal operation (Vcc - VSSD) + (IOVcc-VSSD)	I <sub>OP(IOVcc)</sub>	μA	Vci =2.8V ,IOVcc=2.8V Ta=25°C , GRAM data = 0000h, Frame rate = 70Hz, REV=0, SAP=01111111, AP=100, FS0=00, FS1=11, BT=0100, VC1=111, VC3=000 VRH=0100, VCM=0100000,VDV=01110, VCOMG=1 No panel load	-	150	300	-
Current consumption during normal operation (Vci - VSSD)	I <sub>OP(Vci)</sub>	mA		-	2.7	3.0	-
Current consumption during standby mode (Vcc - VSSD) + (IOVcc-VSSD)	I <sub>ST(IOVcc)</sub>	μA	IOVcc=2.8V , Ta=25°C	-	5	20	-
Current consumption during standby mode (Vci - VSSD)	I <sub>ST(Vci)</sub>	μA		-	0.5	1	-
Output voltage deviation	-	mV	-	-	5	-	-
Dispersion of the Average Output Voltage	V	mV	-	-	-	35	-

6.3 TIMING CHARACTERISTICS

Parallel Interface Characteristics (8080-series MPU)

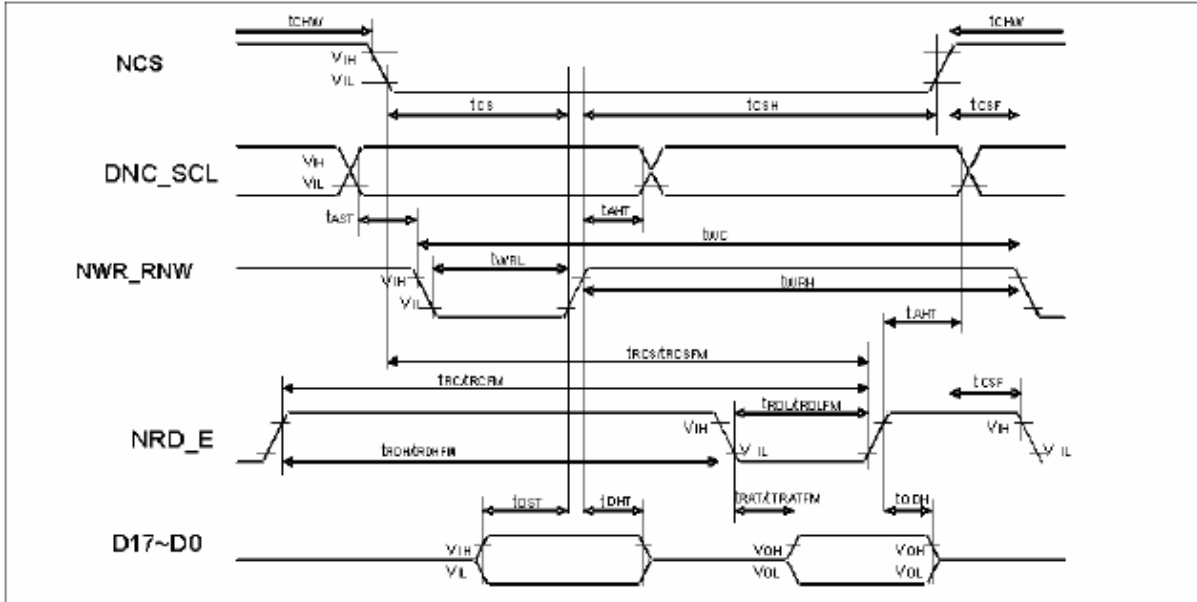

(VSSA=0V, IOVCC=1.65V to 2.9V, VCI=2.3V to 2.9V, Ta = -30 to 70° C)

Signal	Symbol	Parameter	Min.	Max.	Unit	Description
DNC_SCL	tAST	Address setup time	10	-		
	tAHT	Address hold time (Write/Read)	10	-	ns	-
NCS	tCHW	Chip select "H" pulse width	0	-		
	tCS	Chip select setup time (Write)	35	-		
	tRCSFM	Chip select setup time	355	-	ns	-
	tCSF	Chip select wait time (Write/Read)	10	-		
	tCSH	Chip select hold time	10	-		
NWR_RNW	tWC	Write cycle	100	-		
	tWRH	Control pulse "H" duration	35	-	ns	-
	tWRL	Control pulse "L" duration	35	-		
NRD_E	tRCFM	Read cycle	450	-		
	tRDHFM	Control pulse "H" duration	90	-	ns	When read from GRAM
	tRDLFM	Control pulse "L" duration	355	-		
D17 to D0	tDST	Data setup time	15	-		
	tDHT	Data hold time	10	-		
	tRATFM	Read access time	-	340	ns	For maximum CL=30pF
	tODH	Output disable time	20	80		For minimum CL=8pF

Note: The input signal rise time and fall time (tr, tf) is specified at 15 ns or less.

Logic high and low levels are specified as 30% and 70% of IOVCC for Input signals.

**7. PINS DESCRIPTION**

Pin No.	Symbol	Description
1	GND	Ground
2	VDD	Power supply(2.8V)
3	VCI	A Power supply for step-up circuit and power supply circuit.(+2.8v)
4	CS	L:Chip Selected H:Chip Unselected
5	RS	L:Command;H:display data
6	WR	I80 system:Serves as a write
7	RD	I80 system:Serves as a read signal
8	RESET	L: initialization is executed
9-24	DB0-DB15	Data Bus
25	GND	Ground
26	Y+	touch panel output pin.(Touch screen Y corrdinate up)
27	X-	touch panel output pin.(Touch screen X corrdinate left)
28	Y-	touch panel output pin.(Touch screen Y corrdinate down)
29	X+	touch panel output pin.(Touch screen X corrdinate right)
30	LED-K1	Backlight LED cathode(K1)
31	LED-K2	Backlight LED cathode(K2)
32	LED-K3	Backlight LED cathode(K3)
33	LED-K4	Backlight LED cathode(K4)
34	LED-K5	Backlight LED cathode(K5)
35	LEDA	Backlight LED anode
36	LEDA	Backlight LED anode
37	GND	Ground

**8. INSTRUCTION DESCRIPTION**

Register No.	Register	W/R	RS	Upper Code	Lower Code								Comment
				D[17:8]	D7	D6	D5	D4	D3	D2	D1	D0	
R01h	Display Mode control	W/R	1	*	*	*	*	*	IDMON (0)	INVON (1)	NORON (1)	PTLO N(0)	
R02h	Column address start 2	W/R	1	*	SC[15:8] (8'b0)								
R03h	Column address start 1	W/R	1	*	SC[7:0] (8'b0)								
R04h	Column address end 2	W/R	1	*	EC[15:8] (8'b0)								
R05h	Column address end 1	W/R	1	*	EC[7:0] (8'b1110_1111)								
R06h	Row address start 2	W/R	1	*	SP[15:8] (8'b0)								
R07h	Row address start 1	W/R	1	*	SP[7:0] (8'b0)								
R08h	Row address end 2	W/R	1	*	EP[15:8] (8'b0000_0001)								
R09h	Row address end 1	W/R	1	*	EP[7:0] (8'b0011_1111)								
R0Ah	Partial area start row 2	W/R	1	*	PSL[15:8] (8'b0)								
R0Bh	Partial area start row 1	W/R	1	*	PSL[7:0] (8'b0)								
R0Ch	Partial area end row 2	W/R	1	*	PEL[15:8] (8'b0000_0001)								
R0Dh	Partial area end row 1	W/R	1	*	PEL[7:0] (8'b0011_1111)								
R0Eh	Vertical Scroll Top fixed area 2	W/R	1	*	TFA[15:8] (8'b0)								
R0Fh	Vertical Scroll Top fixed area 1	W/R	1	*	TFA[7:0] (8'b0)								
R10h	Vertical Scroll height area 2	W/R	1	*	VSA[15:8] (8'b0000_0001)								
R11h	Vertical Scroll height area 1	W/R	1	*	VSA[7:0] (8'b0011_1111)								
R12h	Vertical Scroll Button area 2	W/R	1	*	BFA[15:8] (8'b0)								
R13h	Vertical Scroll Button area 1	W/R	1	*	BFA [7:0] (8'b0)								
R14h	Vertical Scroll Start address 2	W/R	1	*	VSP [15:8] (8d'0)								
R15h	Vertical Scroll Start address 1	W/R	1	*	VSP [7:0] (8d'0)								
R16h	Memory Access control	W/R	1	*	MY(0)	MX(0)	MV(0)	*	BGR(0)	*	*	*	
R18h	Gate Scan control	W/R	1	*	*	*	*	*	*	*	SCROL L_ON(0)	SM(0)	
R19h	OSC Control 1	W/R	1	*	*	CADJ[3:0] (1000)			CUADJ[2:0] (011)			OSC_EN(0)	
R1Ah	OSC Control 2	W/R	1	*	*	*	*	*	*	*	*	OSC_TEST(0)	
R1Bh	Power Control 1	W/R	1	*	GASEN B(0)	*	*	PON(0)	DK(0)	XDK(0)	VLCD_TRI(0)	STB(0)	
R1Ch	Power Control 2	W/R	1	*						AP[2:0] (100)			
R1Dh	Power Control 3	W/R	1	*	*				*	VC1[2:0] (100)			
R1Eh	Power Control 4	W/R	1	*	*	*	*	*	*	VC3[2:0] (000)			
R1Fh	Power Control 5			*	*	*	*	*	VRH[3:0] (0110)				
R20h	Power Control 6	W/R	1	*	BT[3:0] (0100)				*	*	*	*	

Register No.	Register	W/R	RS	Upper Code	Lower Code								Comment	
				D[17:8]	D7	D6	D5	D4	D3	D2	D1	D0		
R21h	Power Control 7	W/R	1	*	*	*	FS1[1:0] (01)		*	*	FS0[1:0] (00)			
R22h	SRAM Write Control	W/R	1	SRAM Write										
R23h	Cycle Control 1	W/R	1	*	N_DC[7:0] (1001_0101)									
R24h	Cycle Control 2	W/R	1	*	PI_DC[7:0] (1001_0101)									
R25h	Cycle Control 3	W/R	1	*	I_DC[7:0] (1111_1111)									
R26h	Display Control 1	W/R	1	*	PT[1:0] (10)		GON(1)	DTE(0)	D[1:0] (00)		*	*		
R27h	Display Control 2	W/R	1	*	*	*	*	*	N_BP[3:0] (4'b0010)					
R28h	Display Control 3	W/R	1	*	*	*	*	*	N_FP[3:0] (4'b0010)					
R29h	Display Control 4	W/R	1	*	*	*	*	*	PI_BP[3:0] (4'b0010)					
R2Ah	Display Control 5	W/R	1	*	*	*	*	*	PI_FP[3:0] (4'b0010)					
R2Bh	Power Control 11	W/R	1	*	*	*	PI_PRE_REFRE SH[1:0] (00)		BLANK_DIV[3:0] (0000)					
R2Ch	Display Control 6	W/R	1	*	*	*	*	*	I_BP[3:0] (4'b0010)					
R2Dh	Display Control 7	W/R	1	*	*	*	*	*	I_FP[3:0] (4'b0010)					
R35h	Display Control 9	W/R	1	*	EQS[7:0] (0000_1001)									
R36h	Display Control 10	W/R	1	*	EQP[7:0] (0000_1001)									
R37h	Display Control 12	W/R	1	*	*	*	PTG[1:0] (00)		ISC[3:0] (0000)					
R38h	RGB interface control 1	W/R	1	*	*	*	RGB_EN(0)	DPL(0)	HSPL(0)	VSPL(0)	EPL(0)			
R39h	RGB interface control 1	W/R	1	*	DOTCLK_DIV[7:0] (0000_0000)									
R3Ah	Cycle Control 1	W/R	1	*	N_RTIN[3:0] (0000)				*	N_NW[2:0] (001)				
R3Bh	Cycle Control 2	W/R	1	*	PI_RTIN[3:0] (0000)				*	PI_NW[2:0] (001)				
R3Ch	Cycle Control 3	W/R	1	*	I_RTIN[3:0] (1111)				*	I_NW[2:0] (000)				
R3Dh	Cycle Control 4	W/R	1	*	*	*	DIV_I[1:0] (00)		DIV_PI[1:0] (00)		DIV_N[1:0] (00)			
R3Eh	Cycle Control 5	W/R	1	*	SON[7:0] (8'b0011_1000)									
R40	Cycle Control 6	W/R	1	*	GDON[7:0] (8'b0000_0011)									
R41h	Cycle Control 7	W/R	1	*	GDOF[7:0] (8'b1111_1000)									
R42h	BGP Control	W/R	1	*	*	*	VBGP_OE(0)	BGP[3:0] (1000)						
R43h	VCOM Control 1	W/R	1	*	VCOMG(1)	*	*	*	*	*	*	*		
R44h	VCOM Control 2	W/R	1	*	VCM[6:0] (101_1010)									
R45h	VCOM Control 3	W/R	1	*	VDV[4:0] (1_0001)									
R46h	r Control (1)	W/R	1	*	GSEL(0)	CP12(0)	CP11(0)	CP10(0)	*	CP02(0)	CP01(0)	CP00(0)		
R47h	r Control (2)	W/R	1	*	*	CN12(0)	CN11(0)	CN10(0)	*	CN02(0)	CN01(0)	CN00(0)		
R48h	r Control (3)	W/R	1	*	*	NP12(0)	NP11(0)	NP10(0)	*	NP02(0)	NP01(0)	NP00(0)		
R49h	r Control (4)	W/R	1	*	*	NP32(0)	NP31(0)	NP30(0)	*	NP22(0)	NP21(0)	NP20(0)		
R4Ah	r Control (5)	W/R	1	*	*	NP52(0)	NP51(0)	NP50(0)	*	NP42(0)	NP41(0)	NP40(0)		
R4Bh	r Control (6)	W/R	1	*	*	NN12(0)	NN11(0)	NN10(0)	*	NN02(0)	NN01(0)	NN00(0)		
R4Ch	r Control (7)	W/R	1	*	*	NN32(0)	NN31(0)	NN30(0)	*	NN22(0)	NN21(0)	NN20(0)		
R4Dh	r Control (8)	W/R	1	*	*	NN52(0)	NN51(0)	NN50(0)	*	NN42(0)	NN41(0)	NN40(0)		
R4Eh	r Control (9)	W/R	1	*	CGMP11(0)	CGMP10(0)	CGMP01(0)	CGMP00(0)	OP03(0)	OP02(0)	OP01(0)	OP00(0)		
R4Fh	r Control (10)	W/R	1	*	CGMP3(0)	CGMP2(0)	*	OP14(0)	OP13(0)	OP12(0)	P11(0)	OP10(0)		
R50h	r Control (11)	W/R	1	*	CGMN11(0)	CGMN10(0)	CGMN01(0)	CGMN00(0)	ON03(0)	ON02(0)	ON01(0)	ON00(0)		
R51h	r Control (12)	W/R	1	*	CGMN3(0)	CGMN2(0)	*	ON14(0)	ON13(0)	ON12(0)	ON11(0)	ON10(0)		
R52h	OTP Control 1	W/R	1	*	OTP_MASK[7:0] (0000_0000)									
R53h	OTP Control 2	W/R	1	*	OTP_INDEX[7:0] (1111_1111)									
R54h	OTP Control 3	W/R	1	*	OTP_LOAD_DISABLE(0)	DCCLK_DISABLE(0)	OTP_POR(0)	OTP_PWE(0)	OTP_PTM(1)	0	VPP_SEL(0)	OTP_PROG(0)		
R64h	Internal Use 16	R	1	*	ID1[7:0] (8'b0)									
R65h	Internal Use 17	W/R	1	*	*	ID2[6:0] (7'b0)								
R66h	Internal Use 18	W/R	1	*	ID3[7:0] (8'b0)									

Register No.	Register	W/R	RS	Upper Code	Lower Code								Comment
				D[17:8]	D7	D6	D5	D4	D3	D2	D1	D0	
R67h	Himax ID code	R	1	*	HimaxID[7:0](8'h47)								
R70h	Internal Use 28	W/R	1	*	*	GS (0)	SS (0)	TEMO DE(0)	TEON (0)	CSEL[2:0] (110)			
R72h	Data control				*	*	DFM[1:0] (00)		*	TRI [1:0] (00)			
R90h	Display Control 8	W/R	1	*	SAP[7:0] (0000_1010)								
R91h	Display Control 11	W/R	1	*	GEN_OFF[7:0] (0001_0100)								
R93h	OSC Control 3	W/R	1	*	*	*	*	RADJ[3:0] (1111)					
R93h	SAP Idle mode	W/R	1	*	SAP_I[7:0] (0000_1010)								
R93h	DCCLK SYNC TO CL1	W/R	1	*	*	*	*	*	*	*	*	DCCL K_SY NC (0)	

## 9. BACKLIGHT PARAMETERS

ABSOLUTE MAXIMUM RATINGS (Ta=25°C)

Item	Symbol	Condition	Rating	Unit
Operating temperature range	Topr		-20 ~ +70	°C
Storage temperature range	Tstg		-30 ~ +80	°C

(Ta=25°C, Unless specified, The Ambient temperature Ta=25°C)

Item	Symbol	min	typ	max	Unit	Condition
Forward Voltage	Vf	3.0	3.3	3.6	V	If=90mA
Luminance	Lv		3200		cd/m <sup>2</sup>	If=90 mA
White Coordinates	X	0.26		0.31		If=90mA
	Y	0.26		0.31		

## 10. Product Quality & Reliability

### 10.1 Standard for Quality Test

#### 10.1.1 Inspection :

Before delivering, the supplier should take the following tests, and affirm the quality of product.

#### 10.1.2 Electro-Optical Characteristics:

According to the individual specification to test the product.

#### 10.1.3 Test of Appearance Characteristics:

According to the individual specification to test the product.

#### 10.1.4 Test of Reliability Characteristics:

According to the definition of reliability on the specification for testing products.

#### 10.1.5 Delivery Test:

Before delivering, the supplier should take the delivery test.

A. Test method: According to GB/2828, General Inspection Level take a single time.

B. The defects classify of AQL as following:

Major defect: AQL=0.25

Minor defect: AQL=1.0

Total defects: AQL=1.0

**10.2 Standard for inspection**

10.2.1 Manner of appearance test:

- a. The test must be under a 40W fluorescent light, and the distance of view must be at 30~35 cm.
- b. When test the model of transmissive product must add the reflective plate.
- c. The test direction is base on about around 45° of vertical line.

10.2.2 Definition of area: A B

A Area : Viewing area.  
 B Area : Out of viewing area.(Outside viewing area)

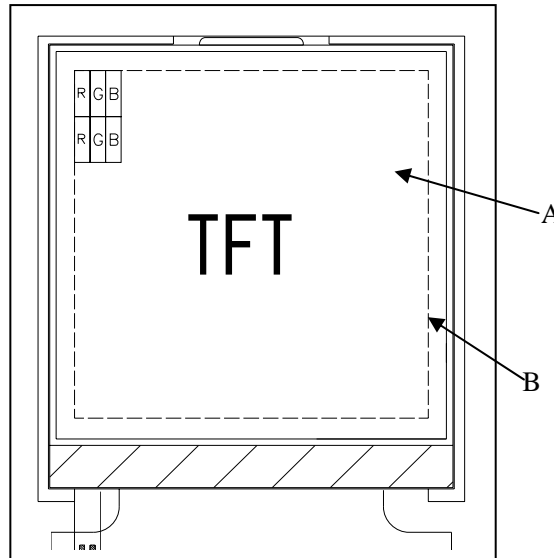

10.2.3 Basic principle:

- A. In principle the defect out of Area A should be acceptable if the defect does not affect assemblage and the quality of productions.
- B. If defects that can not describe clearly, acceptable samples will be the standard.
- C. The sample of the lowest acceptable quality level must be discussed by both supplier and customer when any dispute happened.
- D. Must add new item on time when it is necessary.

10.2.4 Standard of inspection

Defect	Inspect item	Criteria
1 Minor	Scratch and fold on polarizer. Scratch on glass. Glass fiber etc. ( by bare eyes , defect outside A area is acceptable )	1) width ≤ 0.02 mm length ignore acceptable 2) 0.02 mm < width ≤ 0.05 mm length ≤ 3 mm two are acceptable 3) width > 0.05 mm reject

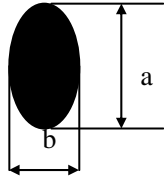

Defect	Inspect item	Criteria
2 Minor	Chip on glass(round type) Chip on polarizer(round type) Air bubble between polarizer and glass  $\Phi=(a + b)/2$	$\Phi \leq 0.1\text{mm}$ acceptable $0.1 < \Phi \leq 0.2\text{mm}$ two are acceptable  1.The distance between any two dots should be more than 5mm. 2.Defect outside A area is acceptable. 3.If the air bubble is black, it can be judged as black spot.

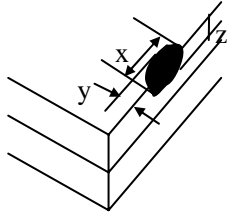
Defect	Inspect item	Criteria
3 Minor	Chip out  x: length y: width z: thickness	$x \leq 3 \text{ mm}$ $z \leq t$ $y \leq 1/3 s$ reject t: glass thickness. S: distance between glass edge and inside of edge sealing

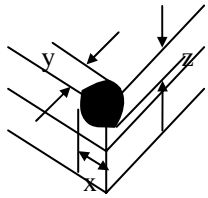
Defect	Inspect item	Criteria
4 Minor	Chip on corner of neat edge  X: length      Y: width S: width of edge sealing	$x \leq 3 \text{ mm}$ $y \leq 3 \text{ mm}$ $z \leq t$  acceptable any chip exposes the silver dot      reject

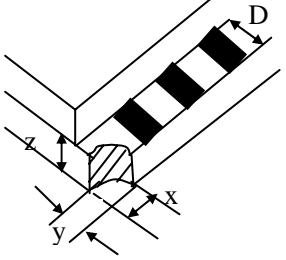
Defect	Inspect item	Criteria
5 Minor	Chip on corner of terminal edge  <p>D: terminal length</p>	$x < 0.3 \text{ mm}$ or $y < 0.3 \text{ mm}$ ignore $x \leq 3 \text{ mm}$ $y < D$ two are acceptable

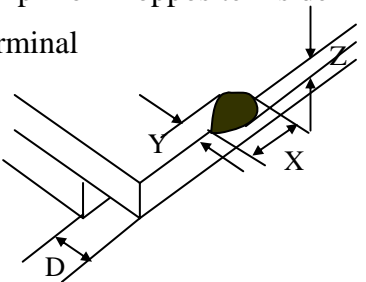
Defect	Inspect item	Criteria
6 Minor	Chip on opposite side of terminal 	$a \geq 80 \text{ mm}$ , $x \geq 7 \text{ mm}$ reject $a < 80 \text{ mm}$ , $x > 5 \text{ mm}$ reject $y > 1/2 D$ reject $z > 1/2 t$ , $y > 1/4 D$ reject D: terminal length

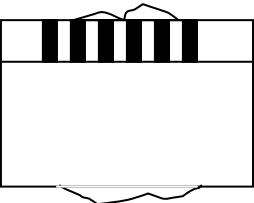
Defect	Inspect item	Criteria
7 Minor	Cutting/breaking defect (flare) 	According to the dimension of drawing

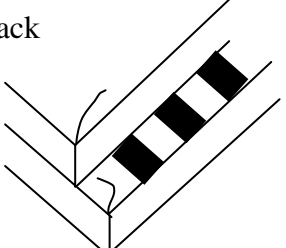
Defect	Inspect item	Criteria
8 Minor	Crack 	Any crack trend to extend reject

Defect	Inspect item	Criteria
9 Major	Liquid leakage, open sealant	reject

Defect	Inspect item	Criteria
10 Minor	Rainbow	According to samples

Defect	Inspect item	Criteria
11 Major	FPC, TCP, FLEX are broken or not connected firmly	reject

Defect	Inspect item	Criteria
12 Minor	The component on PCB or FPC is missing ,soldered unfirmly or bridged	reject

Defect	Inspect item	Criteria
13 Minor	The soldering tin is not enough	The height that soldering tin covers the bump of component is 1/2 less than the height of bump reject

Defect	Inspect item	Criteria
14 Minor	The soldering tin overflows	The soldering tin covers whole bump reject

Defect	Inspect item	Criteria
15 Minor	The component is broken	reject

Defect	Inspect item	Criteria
16 Minor	The shape of pinouts is not the same as that in the criterion	It makes the LCM work badly      reject

Defect	Inspect item	Criteria
17 Minor	The pinout is broken	reject

Defect	Inspect item	Criteria
18 Minor	The frame is scratched visibly	Length                                  ignore Width >0.5mm                          reject

Defect	Inspect item	Criteria
19 Minor	The frame is rusted (accumulation)	When the shape is as dot,reference to defect 23 When the shape is as line,reference to defect 24

Defect	Inspect item	Criteria
20 Minor	Scratch and fold on touchpanel. ( by bare eyes ,defect outside A area is acceptable )	1) width≤0.02 mm                          acceptable 2) 0.02 mm<width≤0.05 mm length≤5 mm                          two are acceptable 3) width>0.05 mm                          reject

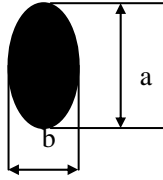
Defect	Inspect item	Criteria
21 Minor	Black & white dots on touchpanel (round type) Air bubble on touchpanel  $\Phi=(a + b)/2$	1) $\Phi \leq 0.1$ mm                          acceptable 2) $0.1 < \Phi \leq 0.3$ mm                          three are acceptable 3) $\Phi > 0.3$ mm                          reject 1.The distance between any two dots should be more than 5mm. 2.Defect outside A area is acceptable. 3.If the air bubble is black, it can be judged as black spot.

Defect	Inspect item	Criteria
22 Minor	Touchpanel warps	According to the dimension of drawing.

Defect	Inspect item	Criteria
23 Minor	Dirty on rear of touchpanel	It's visible at condition of 30±5 cm, 45°

**10.3 RELIABILITY**

Item	Condition	Criterion
High temperature operation	70°C , 96 hrs	-Cosmetic defects are not allowed after the test(Polarizer change is exceptional) -Contrast ratio change over 50% of initial value should not be happened -The current consumption should be below double of initial value -Brightness decrease should be lower than 50% of initial value
Low temperature operation	-20°C , 96 hrs	
Moisture storage	60°C , 90%RH, 96 hrs	
High temperature storage	80°C , 96 hrs	
Low temperature storage	-30°C , 96 hrs	
Thermal shock	-30°C (30 minute) 25°C (5 minute) 80°C (30 minute) CYCLES: 10	

## **11. PRECAUTIONS IN USING**

### **11.1 Liquid crystal display (LCD)**

The LCD panel is made up of glass, organic fluid and polarizer. When handling, please pay attention to the following items:

- 1) Keep the operation and storage temperature of the LCD within the range specified in the LCD specification. Otherwise, excessive temperature and humidity would cause polarization degradation, bubble generation or polarizer peel-off.
- 2) Prevent it from mechanical shock by dropping it from a high place, etc.
- 3) Don't contact, push or rub the exposed polarizers with anything harder than HB pencil lead.
- 4) Avoid using chemicals such as acetone, toluene, ethanol and isoropylalcohol to clean the front/rear polarizers and reflectors, which will cause damage to them.
- 5) Wipe off saliva or water drops immediately. Contact with water over a long period of time may cause deformation or color fading. The LCM is assembled and adjusted with a high degree of precision.
- 6) Do not put or attach anything on the display area. Avoid touching the display area with bare hand.

### **11.2 Precaution for handling LCD modules**

The LCM is assembled and adjusted with a high degree of precision, do not applying excessive shocks to it or making any alterations or modifications to it, the following precautions should be taken when handing.

- 1) Do not drop, bend or twist the module.
- 2) Do not alter or making any modification on the shape of the metal frame.
- 3) Do not change the shape, the pattern wiring or add any extra hole on the PCB.
- 4) Do not modify or touch the zebra rubber strip(conductive rubber) with another object.
- 5) Do not change the positions of components on the PCB.

### **11.3 Eletro-static discharge control**

Careful attention should be paid to control the electrostatic discharge of the modules, since the modules contain no. of CMOS LSI.

- 1) Make sure you are grounded properly when remove the module from its antistatic bag. Be sure that the module and have the same electric potential.
- 2) Only properly grounded soldering iron should be used.
- 3) Modules should be stored in antistatic bag or other containers resistant to static after remove from its original package.
- 4) When using the electric screw-driver is used, make sure the screw driver had been ground potentiality to minimize the transmission of EM wave produced by commutator sparks.
- 5) In order to reduce the generation of static electricity, a relative humidity of 50-60% is recommended.

**11.4 Precaution for soldering**

- 1) Soldering should apply to I/O terminals only.
- 2) Soldering temperature is  $280^{\circ}\text{C}+(-)10^{\circ}\text{C}$ .
- 3) Soldering time 3-4 seconds.
- 4) Eutectic solder (rosin flux filled) should be used.
- 5) If soldering flux is used, be sure to remove any remaining flux after finishing the soldering operation and LCD surface should be covered during soldering to prevent any damage to flux spatters.
- 6) When remove the lead wires from the I/O terminals, use proper de-soldering methods, e.g. suction type de-soldering irons. Do not repeat wiring by soldering more than three times at the pads and plated though holes may be damaged.

**11.5 Precaution for operation**

- 1) Adjust liquid crystal driving voltage ( $V_0$ ) to varies viewing angle and obtain the contrast.
- 2)  $V_0$  should be kept in proper range stated in the specification. Excess voltage will shorten the LCD life.
- 3) Response time is greatly delayed at low temperature. It will recover when go back to normal temperature.
- 4) Condensation on terminals can cause an electrochemical reaction disrupting the terminal circuit. Therefore it should be used under the relative condition of 50% RH.

**11.6 Storage**

When long term storage is required, following precautions are necessary:

- 1) Storage them in a sealed polyethylene bag (antistatic), seal the opening, and store it where it is not subjected to direct sunshine, or to the light of fluorescent lamp. If properly sealed, there is no need for desiccant.
- 2) Store them in the temperature range of  $-30^{\circ}\text{C}\sim 80^{\circ}\text{C}$  and at low humidity is recommended.

## 12. APPLICATION

### 12.1 REFERENCE CIRCUIT

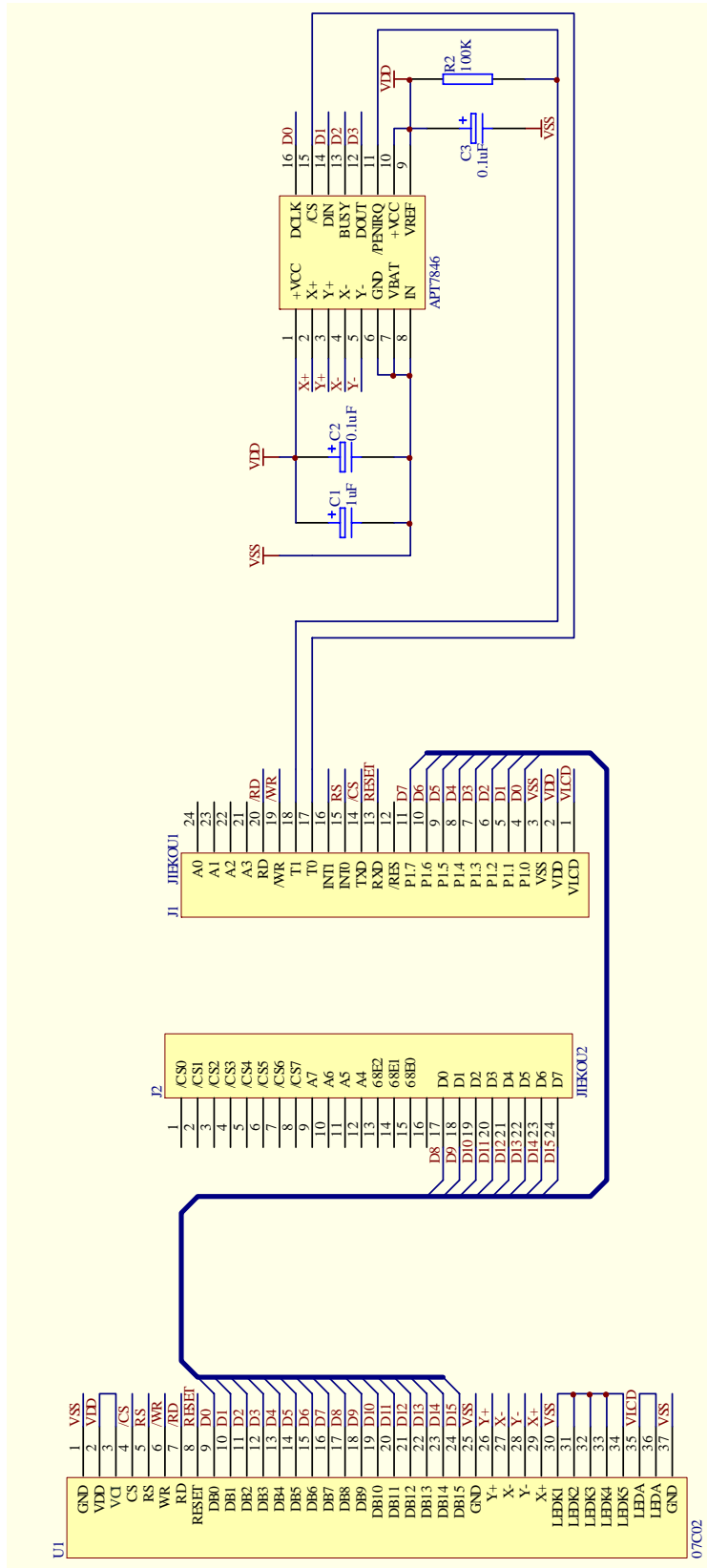



**12.2 APPENDIX**

**INITIALIZATION FOR REFERENCE**

**BINITIAL:**

;  
;\*\*\*\*\*

;Gamma Set:

```
MOV REG,#46H
MOV CMD,#95H
LCALL BWRCTRL
MOV REG,#47H
MOV CMD,#51H
LCALL BWRCTRL
MOV REG,#48H
MOV CMD,#00H
LCALL BWRCTRL
MOV REG,#49H
MOV CMD,#36H
LCALL BWRCTRL
MOV REG,#4AH
MOV CMD,#11H
LCALL BWRCTRL
MOV REG,#4BH
MOV CMD,#66H
LCALL BWRCTRL
MOV REG,#4CH
MOV CMD,#14H
LCALL BWRCTRL
MOV REG,#4DH
MOV CMD,#77H
LCALL BWRCTRL
MOV REG,#4EH
MOV CMD,#13H
LCALL BWRCTRL
MOV REG,#4FH
MOV CMD,#4CH
LCALL BWRCTRL
MOV REG,#50H
MOV CMD,#46H
LCALL BWRCTRL
MOV REG,#51H
MOV CMD,#46H
LCALL BWRCTRL
```

;  
;\*\*\*\*\*

;240x320 window setting:

```
MOV REG,#02H
MOV CMD,#00H
LCALL BWRCTRL
MOV REG,#03H
MOV CMD,#00H
LCALL BWRCTRL
MOV REG,#04H
MOV CMD,#00H
LCALL BWRCTRL
MOV REG,#05H
MOV CMD,#0EFH
LCALL BWRCTRL
MOV REG,#06H
MOV CMD,#00H
LCALL BWRCTRL
MOV REG,#07H
MOV CMD,#00H
LCALL BWRCTRL
MOV REG,#08H
MOV CMD,#01H
LCALL BWRCTRL
MOV REG,#09H
MOV CMD,#3FH
LCALL BWRCTRL
MOV REG,#90H
MOV CMD,#7FH
LCALL BWRCTRL
```

;\*\*\*\*\*

;Display Setting:

```
MOV REG,#01H
MOV CMD,#06H
LCALL BWRCTRL
MOV REG,#16H
MOV CMD,#0C8H
LCALL BWRCTRL
```

```
MOV REG,#23H
MOV CMD,#95H
LCALL BWRCTRL
MOV REG,#24H
MOV CMD,#95H
LCALL BWRCTRL
MOV REG,#25H
```

```
MOV CMD,#0FFH
LCALL BWRCTRL
MOV REG,#27H
MOV CMD,#06H
LCALL BWRCTRL
MOV REG,#28H
MOV CMD,#06H
LCALL BWRCTRL
MOV REG,#29H
MOV CMD,#06H
LCALL BWRCTRL
MOV REG,#2AH
MOV CMD,#06H
LCALL BWRCTRL
MOV REG,#2CH
MOV CMD,#06H
LCALL BWRCTRL
MOV REG,#2DH
MOV CMD,#06H
LCALL BWRCTRL
MOV REG,#3AH
MOV CMD,#01H
LCALL BWRCTRL
MOV REG,#3BH
MOV CMD,#01H
LCALL BWRCTRL
MOV REG,#3CH
MOV CMD,#0F0H
LCALL BWRCTRL
MOV REG,#3DH
MOV CMD,#00H
LCALL BWRCTRL
mov time1,#100
lcall Delay
```

```
MOV REG,#10H
MOV CMD,#0A6H
LCALL BWRCTRL
```

\*\*\*\*\*

;Power Supply Setting:

```
MOV REG,#19H
MOV CMD,#49H
LCALL BWRCTRL
mov time1,#100
```

lcall Delay

MOV REG,#93H  
MOV CMD,#0CH  
LCALL BWRCTRL  
mov time1,#200  
lcall Delay

MOV REG,#20H  
MOV CMD,#40H  
LCALL BWRCTRL

MOV REG,#1DH  
MOV CMD,#07H  
LCALL BWRCTRL

MOV REG,#1EH  
MOV CMD,#00H  
LCALL BWRCTRL

MOV REG,#1FH  
MOV CMD,#04H  
LCALL BWRCTRL

MOV REG,#44H  
MOV CMD,#4DH  
LCALL BWRCTRL

MOV REG,#45H  
MOV CMD,#11H  
LCALL BWRCTRL  
mov time1,#200  
lcall Delay

MOV REG,#1CH  
MOV CMD,#04H  
LCALL BWRCTRL  
mov time1,#200  
lcall Delay

MOV REG,#43H  
MOV CMD,#80H  
LCALL BWRCTRL  
mov time1,#100

lcall Delay

MOV REG,#1BH  
MOV CMD,#18H  
LCALL BWRCTRL  
mov time1,#200  
lcall Delay

MOV REG,#1BH  
MOV CMD,#10H  
LCALL BWRCTRL  
mov time1,#200  
lcall Delay

\*\*\*\*\*

;Display ON Setting:

MOV REG,#26H  
MOV CMD,#04H  
LCALL BWRCTRL  
mov time1,#200  
lcall Delay

MOV REG,#26H  
MOV CMD,#24H  
LCALL BWRCTRL  
mov time1,#40  
lcall Delay

MOV REG,#26H  
MOV CMD,#2CH  
LCALL BWRCTRL  
mov time1,#200  
lcall Delay

MOV REG,#26H  
MOV CMD,#3CH  
LCALL BWRCTRL

MOV REG,#35H  
MOV CMD,#38H  
LCALL BWRCTRL

MOV REG,#36H  
MOV CMD,#78H  
LCALL BWRCTRL

MOV REG,#3EH  
MOV CMD,#38H  
LCALL BWRCTRL

MOV REG,#40H  
MOV CMD,#0FH  
LCALL BWRCTRL

MOV REG,#41H  
MOV CMD,#0F0H  
LCALL BWRCTRL

\*\*\*\*\*

;set spulse & rpulse:

MOV REG,#57H  
MOV CMD,#02H  
LCALL BWRCTRL

MOV REG,#56H  
MOV CMD,#84H  
LCALL BWRCTRL

MOV REG,#57H  
MOV CMD,#00H  
LCALL BWRCTRL

.....TO YOUR CODE