

MINI MCR-SL-UI-UI(-SP)(-NC)

Configurable 3-Way Isolating Amplifier

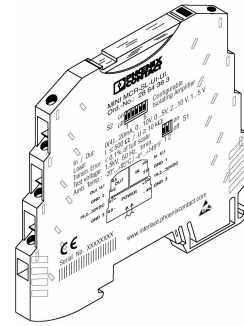

Data Sheet

04/2005

Functions

The configurable 3-way isolating amplifier MINI MCR-SL-UI-UI(-SP)(-NC) is used to electrically isolate, condition, amplify, and filter analog signals.

On the input and output side, the standard signals 0...20 mA, 4...20 mA, 0...10 V, 2...10 V, 0...5 V or 1...5 V are available, electrically isolated.

The DIP switch accessible on the side of the housing allows the configuration of the input and output signal ranges.

The voltage supply (19.2...30 V DC) can either be provided via connecting terminal blocks "3"/"4" or "7"/"8" of the modules, or together, via the DIN rail connector (see Figure 5 on page 7). Please also observe "Power Supply" on page 8.

Features

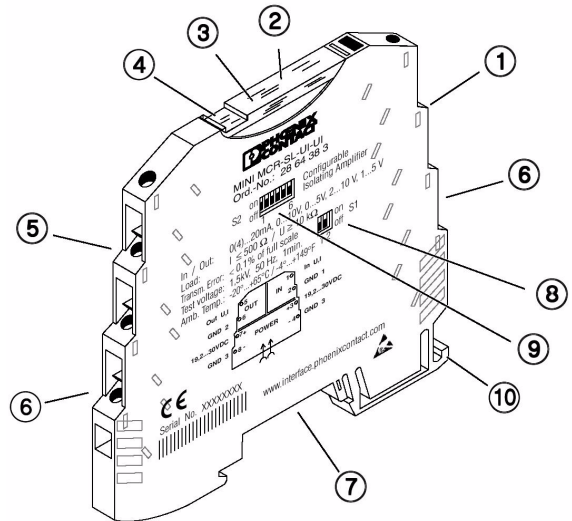







Figure 1 Features

- 1 Input: Standard signals
- 2 Transparent cover
- 3 Potentiometer for adjustment
- 4 Groove for ZBF 6 Zack marker strip
- 5 Output: Standard signals
- 6 Supply voltage
- 7 Connection option for DIN rail connector
- 8 DIP switch S1
- 9 DIP switch S2
- 10 Universal snap-on foot for EN mounting rails

Technical Data

General Data	
Supply voltage	19.2...30 V DC
Current consumption at 24 V DC	< 19 mA, incl. 20 mA load current
Power consumption	< 450 mW
Transmission error	
With alignment	< 0.1%
Without alignment	< 0.4%
Temperature coefficient	
max.	< 0.01%/K
typ.	< 0.002%/K
Cut-off frequency	100 Hz
Step response (10...90 %)	3.5 ms
Test voltage (input / output / supply)	1.5 kV, 50 Hz, 1 min.
Ambient temperature range	
Operation	-20°C...+65°C
Storage	-40°C...+85°C
Dimensions (W x H x D)	6.2 mm x 93.1 mm x 102.5 mm
Conductor cross section	0.2...2.5 mm ² (AWG 24...12)
Stripping length	
Screw connection	12 mm
Spring-cage connection	8 mm
Housing design	Polybutylenterephthalate PBT, green
Tests / Approvals	<p>    </p> <p>  PROCESS CONTROL EQUIPMENT FOR HAZARDOUS LOCATIONS </p> <p> LISTED 31ZN Class I Div 2 Groups A, B, C, D T5 </p> <p> A) This equipment is suitable for use in Class I, Division 2, Groups A, B, C and D or non-hazardous locations only. </p> <p> B) Warning - explosion hazard - substitution of components may impair suitability for Class 1, Division 2. </p> <p> C) Warning - explosion hazard - do not disconnect equipment unless power has been switched off or the area is known to be non-hazardous. </p>
Statement of conformity in acc. with EN 60079-15	 II 3 G Ex nA II T4 X

Input (see Figure 1, detail 1)	I_{IN}	U_{IN}
Input signal range (configurable)	0...20 mA, 4...20 mA	0...10 V, 2...10 V, 0...5 V, 1...5 V
Max. input signal	50 mA	30 V
Input resistance	50 Ω, approx.	100 kΩ, approx.

Output (see Figure 1, detail 5)	I_{OUT}	U_{OUT}
Output signal range (configurable)	0...20 mA, 4...20 mA	0...10 V, 2...10 V, 0...5 V, 1...5 V
Load	< 500 Ω (20 mA)	≥ 10 kΩ
Ripple	< 20 mV _{SS} (500 Ω)	< 20 mV _{SS}
Max. output signal	28 mA / 12.5 V	12.5 V / 22 mA

Conformance With EMC Guideline 89/336/EEC And Low Voltage Directive 73/23/EEC		
Immunity to Interference According to EN 61000-6-2¹		
Discharge of static electricity (ESD)	EN 61000-4-2	Criterion B ²
Electromagnetic HF field	EN 61000-4-3	Criterion A ³
Fast transients (Burst)	EN 61000-4-4	Criterion B ⁴
Surge voltage capacities (Surge)	EN 61000-4-5	Criterion B ⁴
Conducted disturbance	EN 61000-4-6	Criterion A ³
Noise Emission According to EN 61000-6-4		
Noise emission of housing	EN 55011 ⁵	Class A ⁶

¹ EN 61000 corresponds to IEC 1000

² Criterion B: Take protective measures against electrostatic discharge.

³ Criterion A: Normal operating behavior within the defined limits.

⁴ Criterion B: Temporary impairment to operational behavior that is corrected by the device itself.

⁵ EN 55011 corresponds to CISPR11

⁶ Class A: Area of application industry.

Ordering Data

Description	Order Designation	Order No.
Configurable 3-way isolating amplifier Screw terminal block, preconfigured (see "Ordering Key for MINI MCR-SL-UI-UI and MINI MCR-SL-UI-UI-SP" on page 5)	MINI MCR-SL-UI-UI	28 64 38 3
Configurable 3-way isolating amplifier Screw terminal block, standard configuration (see "Standard Configuration" on page 8)	MINI MCR-SL-UI-UI-NC	28 64 15 0
Configurable 3-way isolating amplifier Spring-cage terminal block, preconfigured (see "Ordering Key for MINI MCR-SL-UI-UI and MINI MCR-SL-UI-UI-SP" on page 5)	MINI MCR-SL-UI-UI-SP	28 64 71 0
Configurable 3-way isolating amplifier Spring-cage terminal block, standard configuration (see "Standard Configuration" on page 8)	MINI MCR-SL-UI-UI-SP-NC	28 64 16 3

Accessories

Description	Order Designation	Order No.
DIN rail connector	ME 6,2 TBUS-2 1,5/5-ST-3,81 GN	28 69 72 8
Power terminal block with screw connection	MINI MCR-SL-PTB	28 64 13 4
Power terminal block with spring-cage connection	MINI MCR-SL-PTB-SP	28 64 14 7
System power supply (not for Zone 2!)	MINI-SYS-PS-100-240AC/24DC/1,5	28 66 98 3

Ordering Key for MINI MCR-SL-UI-UI and MINI MCR-SL-UI-UI-SP

If the customer order information is incorrect or missing, the standard configuration is delivered (shown as an example in the ordering key).

Order No.	Input Range	Output Range	Manufacturer's Calibration Certificate WKZ
28 64 38 3 28 64 71 0 (see "Ordering Data")	IN03	OUT01	NONE
	IN01 ≙ 0...20 mA IN02 ≙ 4...20 mA IN03 ≙ 0...10 V IN04 ≙ 2...10 V IN05 ≙ 0...5 V IN06 ≙ 1...5 V	OUT01 ≙ 0...20 mA OUT02 ≙ 4...20 mA OUT03 ≙ 0...10 V OUT04 ≙ 2...10 V OUT05 ≙ 0...5 V OUT06 ≙ 1...5 V	NONE ≙ without WKZ YES ≙ with WKZ (a charge will be made) YESPLUS ≙ WKZ with 5 measuring points (a charge will be made)

Installation

Screw Connection

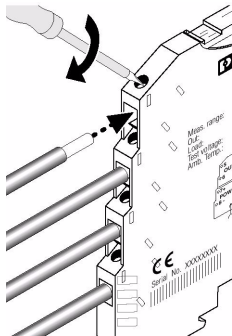

Figure 2 MINI MCR-SL-UI-UI
MINI MCR-SL-UI-UI-NC

Spring-Cage Connection

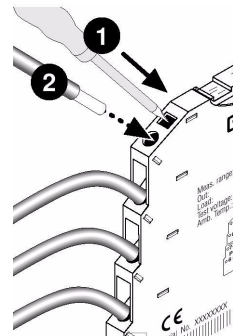

Figure 3 MINI MCR-SL-UI-UI-SP
MINI MCR-SL-UI-UI-SP-NC



The device may only be installed and put into operation by qualified personnel. The corresponding national regulations (e.g. VDE, DIN) must be observed.



Notes for Ex:

The device is category 3 electrical apparatus. Please observe the instructions given here for installation. The device must be installed in a housing with IP54 protection in acc. with EN 60529. The limits for mechanical or thermal loads described for the device must not be exceeded. Only devices designed for operation in the hazardous areas of Zone 2 may be connected. Under no circumstances may repairs be carried out by the user.



Only engage or connect conductors in the hazardous area when the device is deenergized!

The assignment of the connecting terminal blocks is shown in Figure 4.

Block Diagram

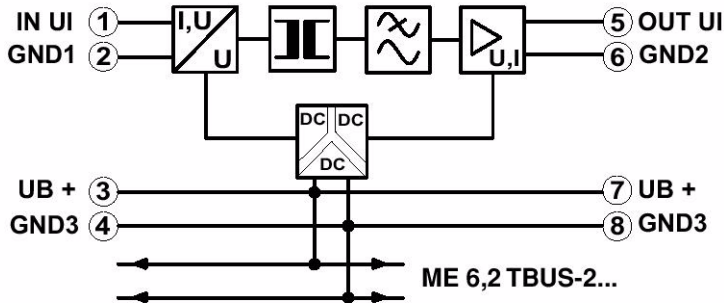

Figure 4 Block diagram

The MINI Analog module can be snapped onto all 35 mm DIN rails corresponding to EN 60715.

Using DIN rail connector ME 6,2 TBUS-2 1,5/5-ST-3,81 GN (Order No.: 28 69 72 8)



Please also pay particular attention to the direction of the MINI Analog module and DIN rail connector when snapping into position:

Snap-on foot (Figure 5, detail D 10)
below and **plug** (Figure 5, detail C 11)
left!

- First position the DIN rail connector in the DIN rail to bridge the voltage supply (see Figure 5).

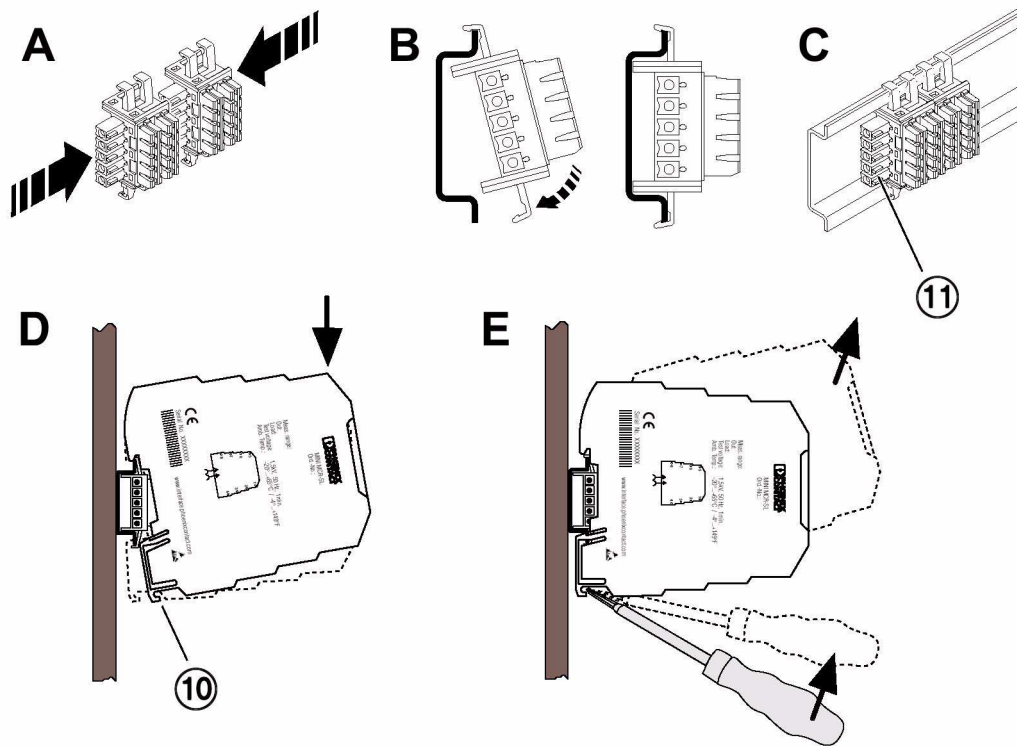

Figure 5 Mounting/Removing

Power Supply



Never connect the supply voltage directly to the DIN rail connector!

It is not permitted to draw power from the DIN rail connector or from individual MINI Analog modules!

Feeding in power via the MINI Analog module

Where the total current consumption of the aligned MINI Analog modules does not exceed 400 mA, the power can be fed in directly at the connecting terminal blocks of a MINI Analog module. We recommend connecting a 400 mA fuse upstream.

Feeding in power with a power terminal block

Power terminal block MINI MCR-SL-PTB (Order No.: 28 64 13 4) or MINI MCR-SL-PTB-SP (Order No.: 28 64 14 7), of the same shape, is used to feed in the supply voltage to the DIN rail connector. We recommend connecting a 2 A fuse upstream.

Feeding in the power with a system power supply unit

System power supply unit MINI-SYS-PS-... (Order No.: 28 66 98 3) with 1.5 A output current contacts the DIN rail connector with the supply voltage, allowing several MINI Analog modules to be supplied from the network.

Configuration



Electrostatic Discharge!

The module contains components that can be damaged or destroyed by electrostatic discharge. When handling the module, observe the necessary safety precautions against electrostatic discharge (ESD), in accordance with EN 61340-5-1 and EN 61340-5-2, as well as IEC 61340-5-1 and IEC 61340-5-2.

DIP switches S1 and S2 (see Figure 1, details 8 and 9) are used to define the combination of input and output standard signal ranges (see "Configuration Table" on page 9).

Standard Configuration

If it is an "NC version" (MINI MCR-SL-UI-UI-NC or MINI MCR-SL-UI-UI-SP-NC), the device has the following standard configuration:

- Input 0...10 V,
- Output 0...20 mA

(All DIP switches in the "off" position, transmission error < 0.1%).

Configuration Table

IN	OUT	DIP S2						DIP S1	
		1	2	3	4	5	6	1	2
0...10 V	0...20 mA	off	off	off	off	off	off	off	off
	4...20 mA	off	off	off	off	off	ON	off	off
	0...10 V	ON	off	ON	off	off	off	off	off
	2...10 V	ON	off	ON	off	off	ON	off	off
	0...5 V	ON	ON	off	off	off	off	off	off
	1...5 V	ON	ON	off	off	off	ON	off	off
2...10 V	0...20 mA	off	off	off	ON	ON	off	off	off
	4...20 mA	off	off	off	off	off	off	off	off
	0...10 V	ON	off	ON	ON	ON	off	off	off
	2...10 V	ON	off	ON	off	off	off	off	off
	0...5 V	ON	ON	off	ON	ON	off	off	off
	1...5 V	ON	ON	off	off	off	off	off	off
0...5 V	0...20 mA	off	off	off	off	off	off	ON	off
	4...20 mA	off	off	off	off	off	ON	ON	off
	0...10 V	ON	off	ON	off	off	off	ON	off
	2...10 V	ON	off	ON	off	off	ON	ON	off
	0...5 V	ON	ON	off	off	off	off	ON	off
	1...5 V	ON	ON	off	off	off	ON	ON	off
1...5 V	0...20 mA	off	off	off	ON	ON	off	ON	off
	4...20 mA	off	off	off	off	off	off	ON	off
	0...10 V	ON	off	ON	ON	ON	off	ON	off
	2...10 V	ON	off	ON	off	off	off	ON	off
	0...5 V	ON	ON	off	ON	ON	off	ON	off
	1...5 V	ON	ON	off	off	off	off	ON	off
0...20 mA	0...20 mA	off	off	off	off	off	off	off	ON
	4...20 mA	off	off	off	off	off	ON	off	ON
	0...10 V	ON	off	ON	off	off	off	off	ON
	2...10 V	ON	off	ON	off	off	ON	off	ON
	0...5 V	ON	ON	off	off	off	off	off	ON
	1...5 V	ON	ON	off	off	off	ON	off	ON
4...20 mA	0...20 mA	off	off	off	ON	ON	off	off	ON
	4...20 mA	off	off	off	off	off	off	off	ON
	0...10 V	ON	off	ON	ON	ON	off	off	ON
	2...10 V	ON	off	ON	off	off	off	off	ON
	0...5 V	ON	ON	off	ON	ON	off	off	ON
	1...5 V	ON	ON	off	off	off	off	off	ON

Alignment

Below the transparent cover is a potentiometer (see Figure 1, detail 3), with which a fine adjustment of the analog signals can be carried out after the configuration of the DIP switches has been altered.



The transmission error without adjustment is $< 0.4\%$. Using the potentiometer, the error can be adjusted to $< 0.1\%$.



Make sure you always use the latest documentation. It can be downloaded at www.download.phoenixcontact.com.

A conversion table is available on the Internet at www.download.phoenixcontact.com/general/7000_en_00.pdf.

PHOENIX CONTACT GmbH & Co. KG
Flachsmarktstr. 8
32825 Blomberg
Germany



+ 49 - (0) 52 35 - 3-00



+ 49 - (0) 52 35 - 3-4 12 00



www.phoenixcontact.com



Worldwide Locations:

www.phoenixcontact.com/salesnetwork