

D-16

ALIGNMENT TOOL KIT



- These alignment tools are used to adjust ferrite cores and semi-fixed volumes.
- Material: Polyacetal

Set contents D-16-1B / D-16-2B / D-16-3B /  
D-16-4B / D-16-5

Color D-16-1B to 4B Blue / D-16-5 White

Weight 45 g

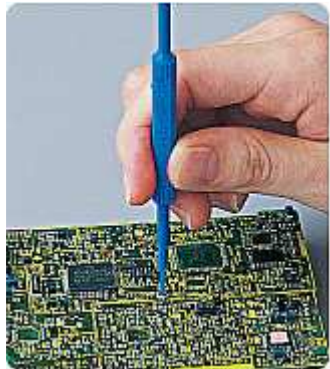

Alignment tool

Part no.	Tip size mm	Weight g
D-16-1B	■ 1.35 × 0.7 / 1.4 × 0.8 ● 1.4 / 1.5 ● 2.6 / 2.7	
D-16-2B	■ 1.9 × 0.9 ● 1.95 / 2.0 / 2.6 / 2.65	3
D-16-3B	■ 2.65 × 1 / 3.1 × 1.2 ● 2.65 / 3.1 / .18 / 3.35	
D-16-4B	■ 2.3 × 0.4 ⊗ 3.6 × 0.4 (with guide)	4
D-16-5	◎ Inner φ 5.5 Outer dia.: φ 8.0	3

\*Unnecessary sizes can be cut, and then used.

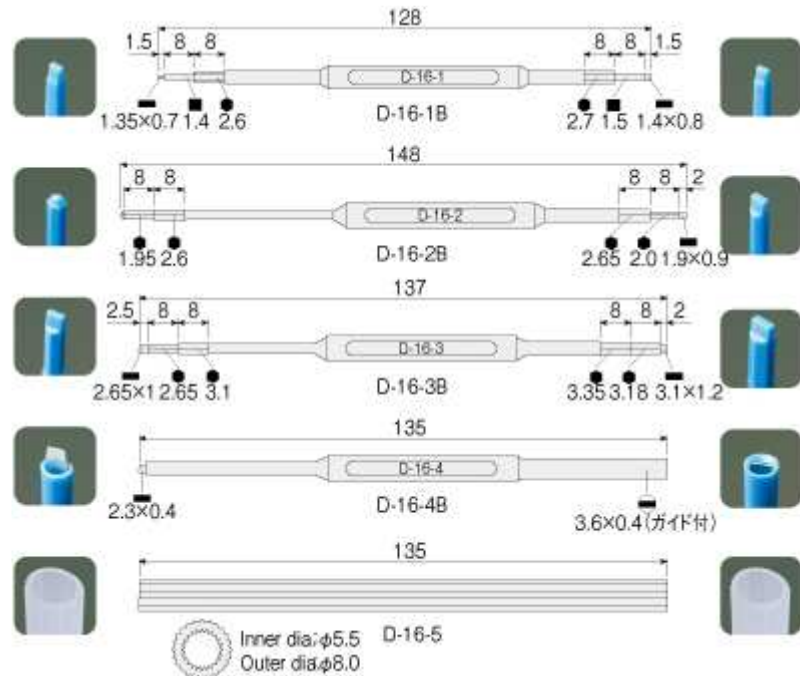

# HOZAN D-16

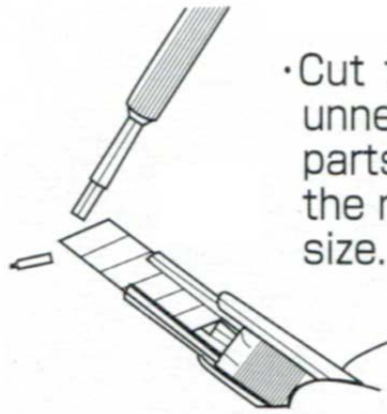
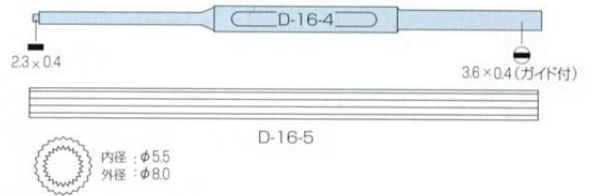
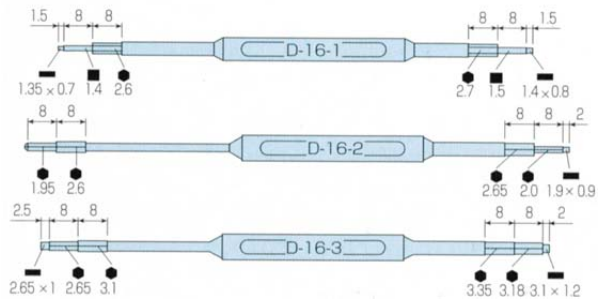

• Cut the unnecessary parts to gain the required size.