

OVERALL ASSEMBLY DIMENSIONS:

EXTERNAL - 110 x 60 x 40

INTERNAL - 105 x 55 x 32.5

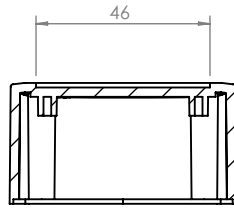

SECTION B-B

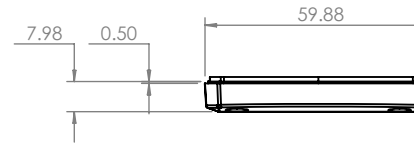

ISO VIEW
1:3

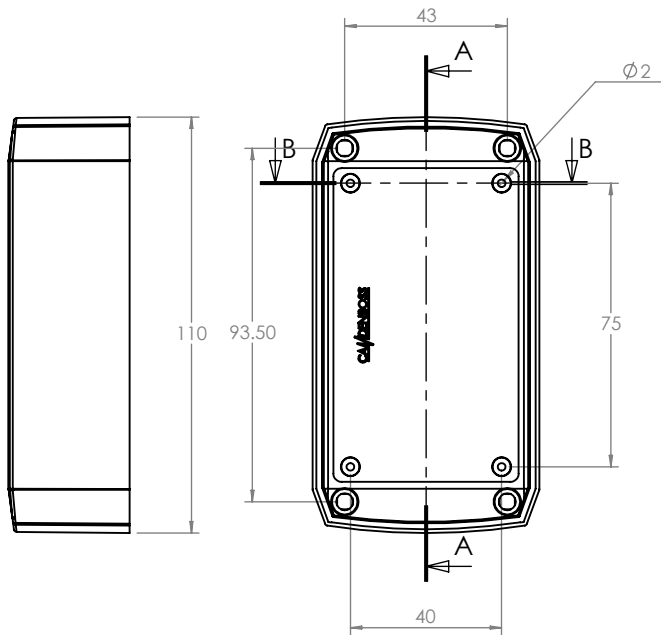

BASE

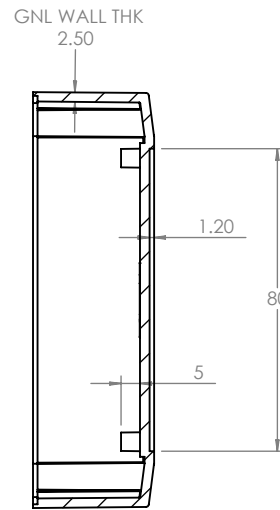

SECTION A-A

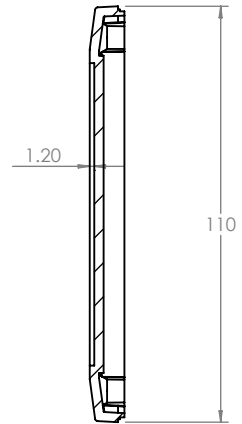
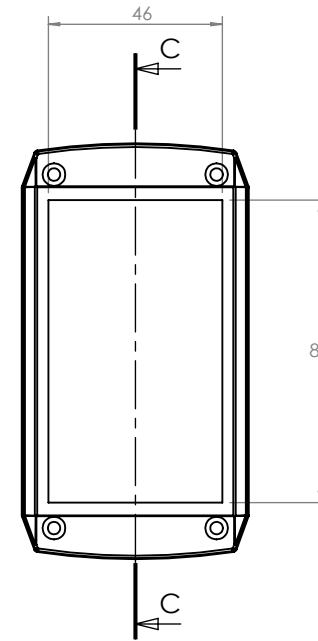

SECTION C-C LID

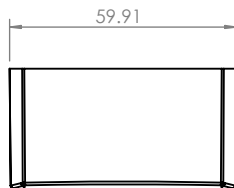

CAMDENBOSS
ELECTRONICS & ENCLOSURES

JAMES CARTER RD, MILDENHALL, SUFFOLK. IP28 7DE
TEL: 01638 716101 FAX: 01638 716554
EMAIL: Sales@CamdenBoss.com
WEB: www.CamdenBoss.com

UNLESS OTHERWISE SPECIFIED:
DIMENSIONS ARE IN MILLIMETERS

FINISH:
SMOOTH

MATERIAL: ABS &
POLYCARBONATE

PROJECTION:

DO NOT SCALE DRAWING

REVISION: 0

TITLE: GNL ASSEMBLY DRG FOR
1101 SERIES - CSACT002

DWG NO. CSACTT002

A4

	NAME	SIGNED	DATE
DRAWN	IAN PAGANO	I.P.	17/06/13
CHKD	-	-	-

SCALE: 1 : 2

SHEET 1 OF 1