

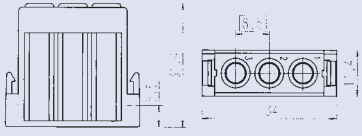



# heavy|mate® M 3 contacts module + crimp contacts

Description	Part Number	Drawing	Figure
<b>3 contacts module (Please order contacts separately)</b>			
Pin module	C146 A03 001 E8		
Socket module	C146 B03 001 E8		

Supplied as	for wire gauge	AWG	Pieces	Part Number		Figure
				Male contact	Female contact	
<b>Turned 3.6 mm crimp contacts single contact</b>						
silver plating	1.5 mm <sup>2</sup>	16	100	VN01 036 0004 (1)C	VN02 036 0004 (1)C	
	2.5 mm <sup>2</sup>	14	100	VN01 036 0005 (1)C	VN02 036 0005 (1)C	
	4.0 mm <sup>2</sup>	12	100	VN01 036 0001 (1)C	VN02 036 0001 (1)C	
	6.0 mm <sup>2</sup>	10	100	VN01 036 0002 (1)C <sup>1)</sup>	VN02 036 0002 (1)C <sup>1)</sup>	
	10.0 mm <sup>2</sup>	8	100	VN01 036 0003 (1)C <sup>1)</sup>	VN02 036 0003 (1)C <sup>1)</sup>	

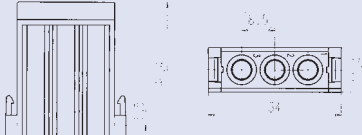
<b>Tools</b>					
Description	for wire gauge	Part Number			Tool
		Contact locator	Crimping dies		
Removal tool for contacts	-	-	-	-	FG 0300 146 3
Removal tool for modules	-	-	-	-	FG 1000 146
Crimping tool for single contacts	1.5 - 2.5 mm <sup>2</sup>	TA 0010 146 000 5	TA 0000 144		TA 0000
	4.0 mm <sup>2</sup>	TA 0010 146 000 4	TA 0000 124		
	6.0 mm <sup>2</sup>	TA 0010 146 000 4	TA 0000 124		
4-indent crimping tool <sup>2)</sup>	1.5 - 10.0 mm <sup>2</sup>	-	-	-	TB 0200 146
Crimping tool for cable lugs	6.0 mm <sup>2</sup>	-	TA 0000 180		TA 0000
	10.0 mm <sup>2</sup>	-			
<b>Cable lugs for PE connection</b>				<b>Pieces</b>	<b>Part Number</b>
Cable lug	6.0 mm <sup>2</sup>	-	20		N15 006 000 9Z
	10.0 mm <sup>2</sup>	-	20		N15 010 000 7Z
Further tools see catalogue "Tools"					