

Solid State Relays

Industrial, 1-Phase DCS

Types RD 0605 -D, RD 2001 -D, RD 3501 -D



- DC Solid State Relay
- Rated operational current: 1 and 5 ADC
- Operational voltage range: Up to 350 VDC
- Input range: 3 to 32 VDC
- Insulation: OPTO (input-output) 4000 VACrms

Product Description

The DC switching relay is used in applications in which there is a need for fast switching of small DC loads with a high input/output insulation of more

than 4000 VACrms. The DC switching transistor relay always switches ON and OFF in accordance with the applied control voltage.

Ordering Key

RD 06 05 -D

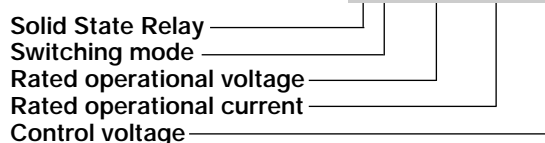

Type Selection

Switching mode	Rated operational voltage	Rated operational current	Control voltage
D: DC switching	06: 60 VDC 20: 200 VDC 35: 350 VDC	01: 1 ADC 05: 5 ADC	-D: 3 to 32 VDC

Selection Guide

Rated operational voltage	Control voltage	Rated operational current	
60 VDC	3 to 32 VDC	1 ADC	5 ADC
200 VDC	3 to 32 VDC	RD 2001 -D	RD 0605 -D
350 VDC	3 to 32 VDC	RD 3501 -D	

General Specifications

	RD 0605 -D	RD 2001 -D	RD 3501 -D
Operational voltage range	3 to 60 VDC	3 to 200 VDC	3 to 350 VDC
Off-state blocking voltage	≥ 60 VDC	≥ 200 VDC	≥ 350 VDC
Approval	CSA	CSA	CSA
CE-marking	Yes	Yes	Yes

Input Specifications

	RD 2001 -D RD 3501 -D	RD 0605 -D
Control voltage range	3 to 32 VDC	3 to 32 VDC
Pick-up voltage	≤ 3 VDC	≤ 3 VDC
Drop-out voltage	≥ 1 VDC	≥ 1 VDC
Reverse voltage	≤ 32 VDC	≤ 32 VDC
Activating frequency	≤ 100 Hz	≤ 100 Hz
Input impedance	1 kΩ	1 kΩ
Response time pick-up @ V in ≥ 5 V	≤ 100 μs	≤ 100 μs
Response time drop-out	≤ 1 ms	≤ 1 ms
Input pulse rise and fall time	≤ 100 μs	no limit

Output Specifications

	RD 2001 -D RD 3501 -D	RD 0605 -D
Rated operational current DC 1	1 A	5 A
Minimum operational current	1 mA	1 mA
Rep. overload current t=1 s	≤ 2 A	≤ 10 A (15A@80ms)
Off-state leakage current @ rated voltage	≤ 1 mA	≤ 1 mA
On-state voltage drop @ rated current	≤ 1.5 V	≤ 1.5 V

Thermal Specifications

Operating temperature	-20° to +70°C (-4° to +158°F)
Storage temperature	-40° to +100°C (-40° to +212°F)
Junction temperature	≤ +150°C (+302°F)
R _{th} junction to case	≤ 3 K/W
R _{th} junction to ambient	≤ 15 K/W

Insulation

Rated insulation voltage Input to output	≥ 4000 VACrms
Rated insulation voltage Output to case	≥ 4000 VACrms
Insulation resistance Input to output	≥ 10 ¹⁰ Ω
Insulation resistance Output to case	≥ 10 ¹⁰ Ω
Insulation capacitance Input to output	≤ 8 pF
Insulation capacitance Output to case	≤ 50 pF

Wiring Diagrams

RD 2001-D RD 3501-D

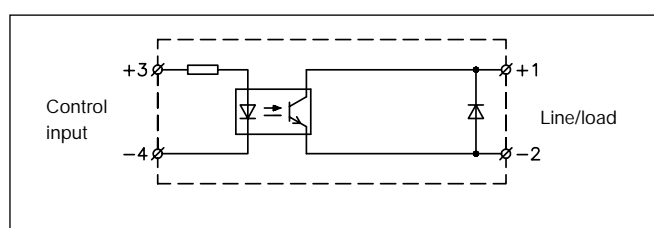

RD 0605 -D

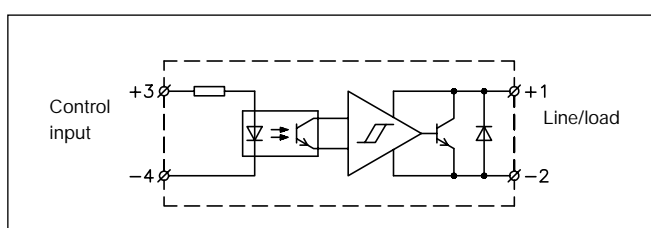



Functional Diagrams

RD 0605-D

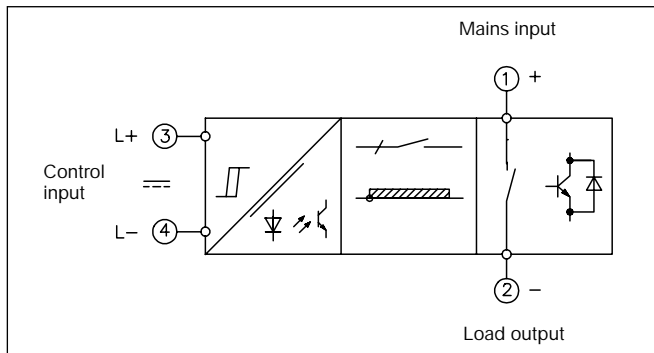

RD 2001-D RD 3501-D

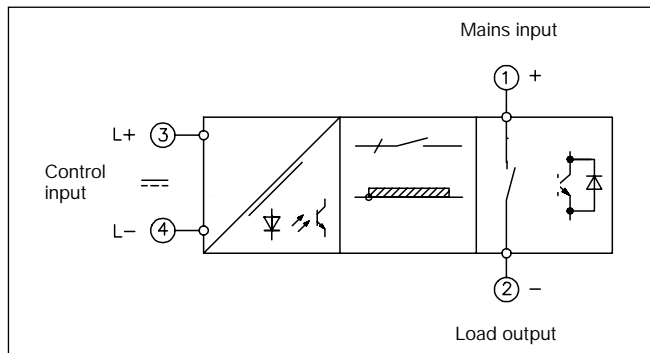

Applications

High-power switching

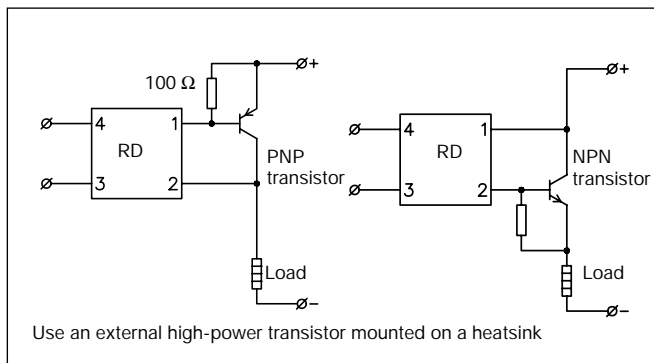

Inductive load

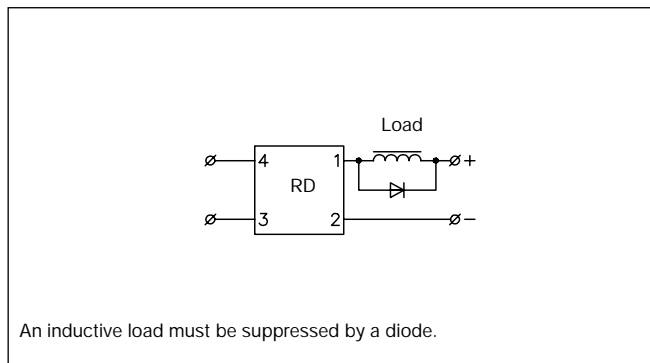

Fusing

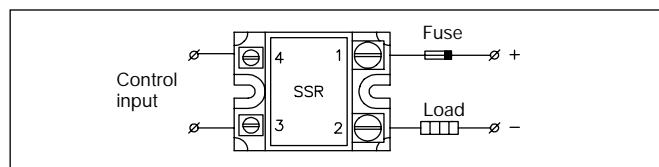

Heatsink Dimensions

RD 0605 -D

Load current [A DC]	Thermal resistance [K/W]					
	20	30	40	50	60	70
5	10.7	9.3	8	6.7	5.3	4
4	13.3	11.7	10	8.3	6.7	5
3	-	-	13.3	11.1	8.8	6.7
2	-	-	-	-	13.3	10
1	-	-	-	-	-	-

T_A
Ambient temp. [°C]

Heatsink Selection

Carlo Gavazzi Heatsink (see Accessories)	Thermal resistance
No heatsink required RHS 100 Assy	$R_{th\ s-a} > 12.5$ K/W 3.0 K/W

Compare the value found in the current versus temperature chart with the standard heatsink values and select the heatsink with the next lower value.

Frequency = 0 to 10 Hz.
Types RD 2001-D and RD 3501-D require no heatsinking.

Dimensions

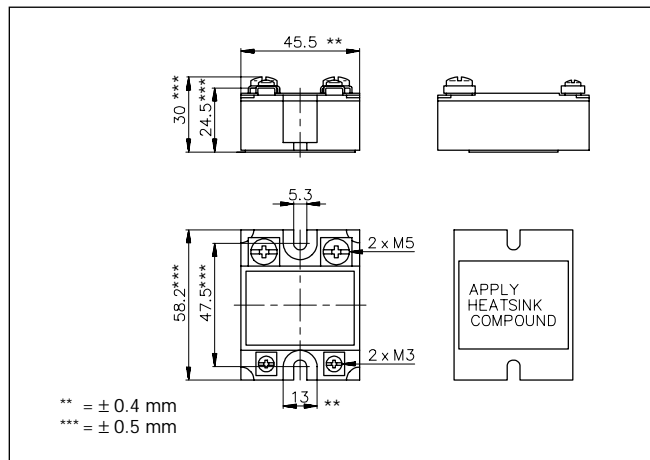

Housing Specifications

Weight	Approx. 110 g
Housing material	Noryl GFN 1, black
Base plate	Aluminium
Potting compound	Polyurethane
Relay	
Mounting screws	M5
Mounting torque	≤ 1.5 Nm
Control terminal	
Mounting screws	M3 x 6
Mounting torque	≤ 0.5 Nm
Power terminal	
Mounting screws	M5 x 6
Mounting torque	≤ 2.4 Nm

Accessories

Protection cover
Heatsinks
DIN rail adapter
Varistors
Fuses

For further information refer to "General Accessories".