

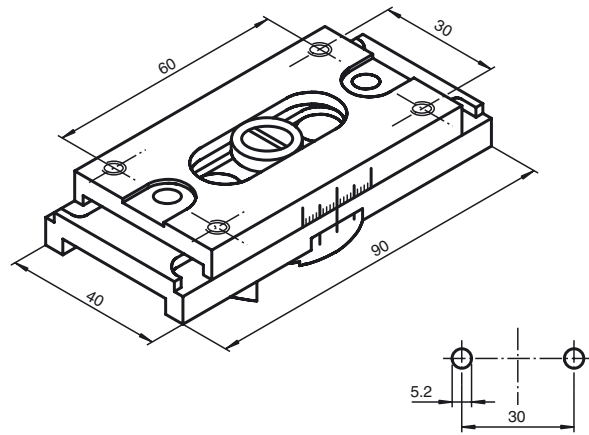

Dimensions



Model number

MH 04-2681F

Mounting aid for VariKont, +U1+ and +U9*

Features

- Suitable for VariKont, +U1+ and +U9* sensors
- Fixing screws for VariKont included in delivery

Function

The mounting bracket type 04-2681 simplifies the adjustment of sensors of the model line VariKont® and the series +U1+ and +U9* according to DIN 43694, EN 50025 or EN 50037.

Fitting is simple using the well-tried and tested C section rail (e.g. NIEDAX GmbH) according to EN 50024 (15 mm x 30 mm x 1.5 mm). For existing installations, the mounting bracket is suitable for the C section rail according to the expiring DIN 43662 (15 mm x 30 mm x 2 mm).

Instead of the C section rail, two-point fitting is possible. The respective drill holes are accessible via the middle guiding slot. Screws M5 x 16 mm can be used.

Large adjusting ranges in x and y direction and the 360° turning range simplify and reduce the mounting and adjustment work.

The selected position can be adjusted by tightening the sensor mounting screws (included in the delivery package).

Technical data

Standard conformity

Standards IEC 68-2-6, IEC 68-2-27

Ambient conditions

Shock resistance b < 30 g, T < 11 ms
 Vibration resistance f < 55 Hz, a < 1 mm

Mechanical specifications

Material pressure-diecast zinc chrom coated
 Mass approx. 270 g
 Dimensions 90 mm x 40 mm x 28 mm (in case of two-point fixing)