

An economic compact limit switch equipped with a forced contact opening mechanism and excellent environment proofing (IP67).



(Roller arm) + (Conduit connector)

CHARACTERISTICS

1. Forced contact opening mechanism

When the limit switch is ON, the contact is forced open by the N.C. contact through the cam movement.

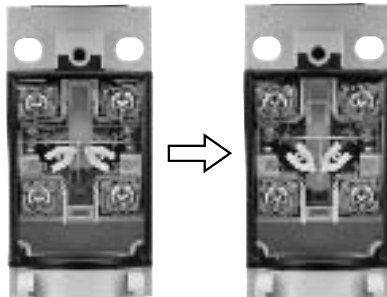

2. Conforms to EN standard (EN50047)

3. Uses a unit system

Any combination of actuator, head block, and unit block is possible. The units are also sold separately, making maintenance easy.

4. Hinged cover for easy wiring

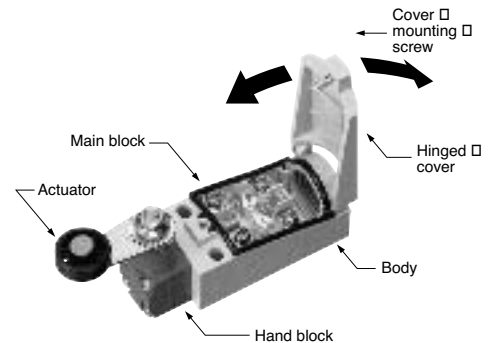

5. Protective construction (IP67), and wide operating temperature range (-30°C to +80°C -22°F to +176°F)

TYPICAL APPLICATIONS

General plant facilities such as food processing, light machinery such as packaging machines, and assembly lines.

PRODUCT TYPE

1. Basic products

Actuator	Part No.	
	PF type	PG type
Roller Lever	AZD1000	AZD1050
Push Plunger	AZD1001	AZD1051
Roller Plunger	AZD1002	AZD1052
Roller Arm	AZD1004	AZD1054
Adjustable Roller Arm	AZD1008	AZD1058
Adjustable roller arm (50 dia. rubber roller)	AZD1003	AZD1053
Adjustable rod (2.6 dia.)	AZD1007	AZD1057
Roller lever (vertical action)	AZD1009	AZD1059

Notes: 1. Type of conduit size: PF type (G1/2), PG type (PG13.5)
2. PG is a size standard used in Europe.

2. Blocks

Product name		Part No.	
Type of actuators	Roller Lever	AZD1800	
	Roller Arm	AZD1804	
	Adjustable Roller Arm	AZD1808	
Head block		AZD1820	
Main block	For plunger	PF type	AZD1001
		PG type	AZD1051
	For arm type	PF type	AZD1104
		PG type	AZD1154

3. Conduit connector

Product name	Part No.
PF type conduit connector	AZD1830

Note: The conduit connector is for cables.
Rubber seals with an inside diameter of 9 and 11 are attached.

FOREIGN STANDARDS

Standards	Applicable product	Part No.
UL	File No. : E122222 Ratings : 6A 380V AC Pilot duty A300 Product type : All models	Order by standard part No.
CSA	File No. : LR55880 Ratings : 6A 380V AC Pilot duty A300 Product type : All models	
TÜV	File No. : J9551205 Ratings : AC-15 2A/250V~ Pilot duty A300 Product type : All models	

PRODUCT COMBINATION

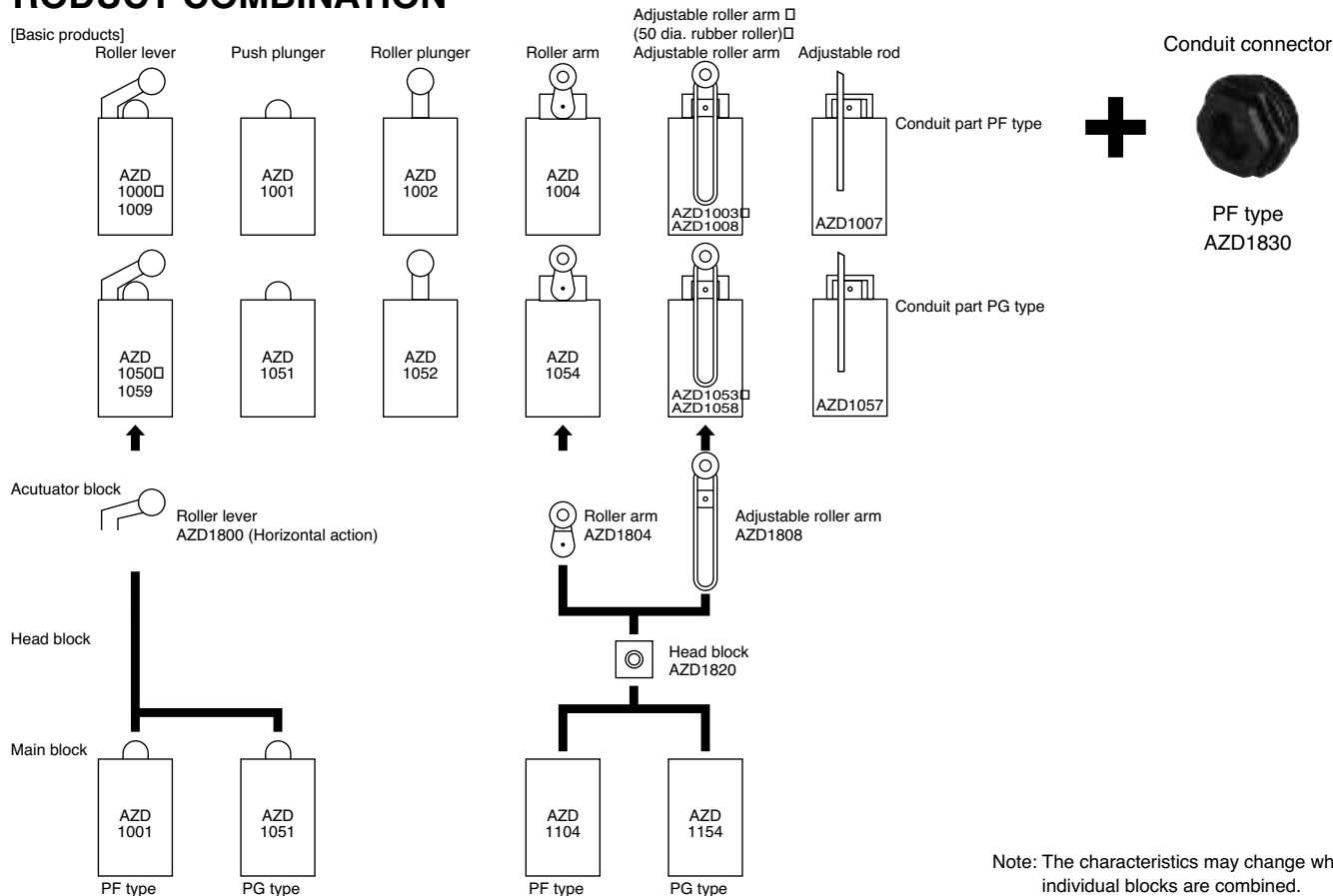

Note: The characteristics may change when the individual blocks are combined.

SPECIFICATIONS

1. Rating

Voltage	Load	Resistive load	Inductive load
		($\cos \phi \approx 1$)	($\cos \phi \approx 0.4$)
AC	125V	6A	6A
	250V	6A	6A
	380V	6A	3A
DC	24V	5A	2.5A
	60V	1.5A	1.5A
	220V	0.3A	0.3A

Note: When DC voltage is applied, the time constant is (τ)= 0ms for resistive load, (τ)= 100ms or less for inductive load.

3. EN60947-5-1 performance

Item	Rating
Rated insulation voltage (Ui)	250VAC Note*
Rated impulse withstand voltage (Uimp)	2.5kV Note*
Switching overvoltage	2.5kV
Rated enclosed thermal current (Ithe)	6A
Conditional short-circuit current	100A
Short-circuit protection device	10A Fuse
Protective construction	IP67 (Note 1)
Pollution degree	2

Note) * The ratings, performance and operating characteristics are based on the basic model.

Note 1: Adjustable roller arm (50 dia. rubber roller) type is IP65.

5. Protective characteristics

Protective construction	DL mini limit switches
IEC	
IP60	○
IP64	○
IP67	○ (Note 1)

Note 1: The value for protective function characteristics is the initially set value. Also, adjustable roller arm (50 dia. rubber roller) type is IP65.

The switches are compatible with DIN EN50047.

2. Characteristics

Contact arrangement	1a1b	
Initial contact resistance, max.	25mΩ (By voltage drop of 5 to 6 V DC 1A)	
Contact material	Silver alloy	
Initial insulation resistance (At 500V DC)	Min. 100MΩ	
Initial breakdown voltage	1,000Vrms for 1 min	Between non-consecutive terminals
	2,500Vrms for 1 min	Between dead metal parts and each terminal
	2,500Vrms for 1 min	Between ground and each terminal
Shock resistance	Functional	Max. 294 m/s ² (equivalent 30G) (Noe 1)
	Destructive	Max. 980 m/s ² (equivalent 100G)
Vibration resistance	10 to 55Hz, double amplitude of 1.5mm	
Expected life (min. operations)	Mechanical	10 ⁷ (at 120 cpm)
	Electrical	1.5×10 ⁵ (at 20 cpm, 6A 380V AC resistive load)
Ambient temperature	-30 to +80°C -22°F to +176°F (but not in a frozen environment)	
Ambient humidity	Max. 95%R.H. (without dew at 40°C 104°F)	
Max. operating speed	120 cpm	

Note: The ratings, performance and operating characteristics are based on the basic model.

Note 1: This value applies when the arm length of the adjustable roller arm (50 dia. rubber roller) is 70 mm or less.

4. Operating characteristics

Characteristics	Actuator					
	O.F. (N {gf}) max.	R.F. (N {gf}) min.	Pretravel (P.T.), max. mm inch	Movement Differential (M.D.), max. mm inch	Overtravel (O.T.), min. mm inch	Operating Position (O.P.), mm inch
Push plunger	6.37 {650}	1.47 {150}	2.079	1.2 .047	4.157	18±0.5 .708±.020
Roller plunger	6.37 {650}	1.47 {150}	2.079	1.2 .047	4.157	28±1 1.102±.03
Roller arm	4.90 {500}	0.49 {50}	20° to 26°	14°	30°	—
Roller lever	3.92 {400}	0.78 {80}	4.157	1.6 .063	5.197	—
Adjustable roller arm	4.90 {500}	0.49 {50}	20° to 26°	14°	30°	—
Adjustable roller arm (50 dia. rubber roller)	4.17 {425}	0.42 {43}	20° to 26°	14°	30°	—
Adjustable rod (2.6 dia.)	4.90 {500}	0.49 {50}	20° to 26°	14°	30°	—
Roller lever (vertical action)	4.41 {450}	0.88 {90}	4.157	1.7 .067	5.197	27±0.8 1.063±.031

Note: The above values of adjustable roller arm shows the values when roller length is set at 26mm same as roller type.

The value of adjustable roller arm (50 dia. rubber roller) type shows the value when roller length is set at 32 mm.

The value of adjustable rod (2.6 dia.) type shows the value when length of rod is set at 26 mm same as the roller arm type.

DL (AZD1)

WIRING DIAGRAM

Internal circuit

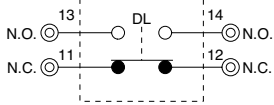

Terminals



DIMENSIONS

mm inch

Head block



AZD1820

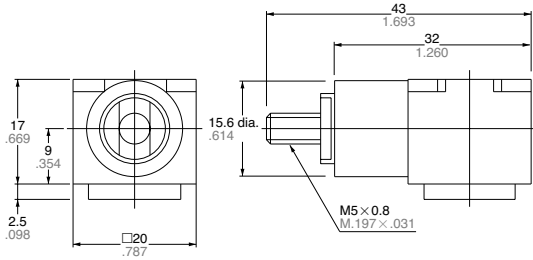

General tolerance: $\pm 0.4 \pm 0.16$

Roller lever type



AZD1000
AZD1050

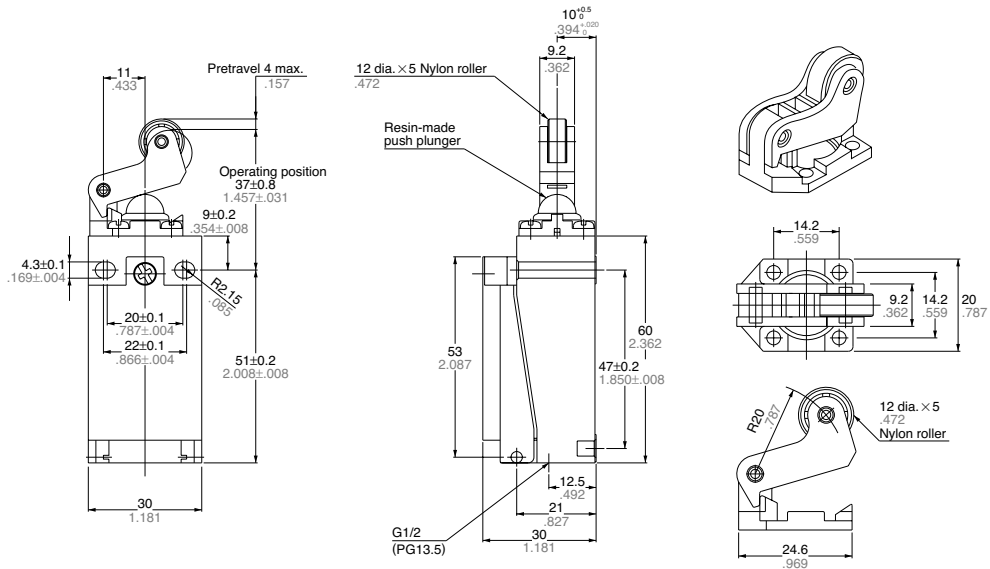

General tolerance: $\pm 0.4 \pm 0.16$

Push plunger type



AZD1001
AZD1051

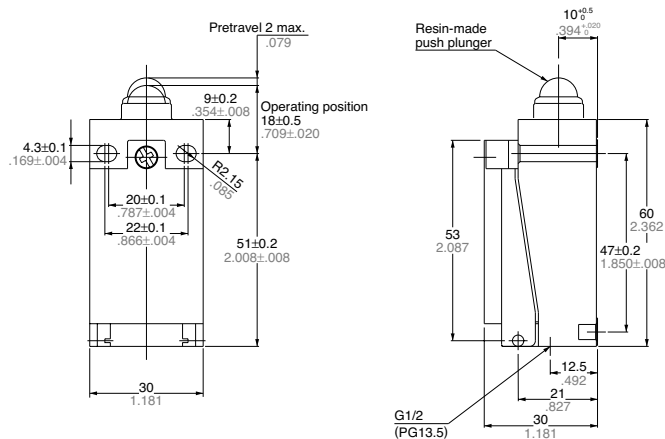

General tolerance: $\pm 0.4 \pm 0.16$

Roller plunger type



AZD1002
AZD1052

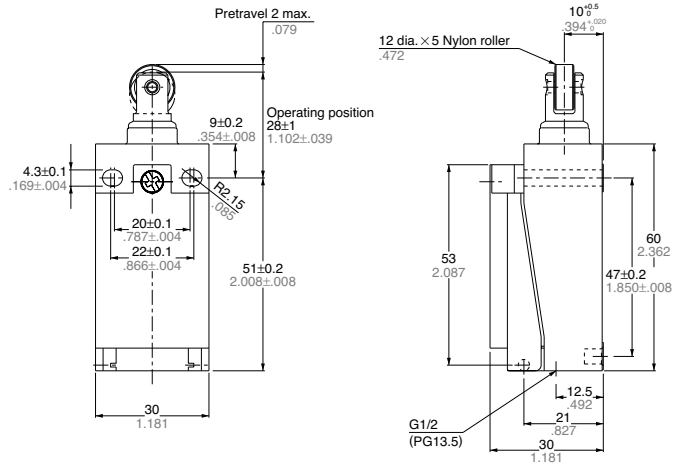

General tolerance: $\pm 0.4 \pm .016$

Adjustable roller arm (50 dia. rubber roller)



AZD1003
AZD1053

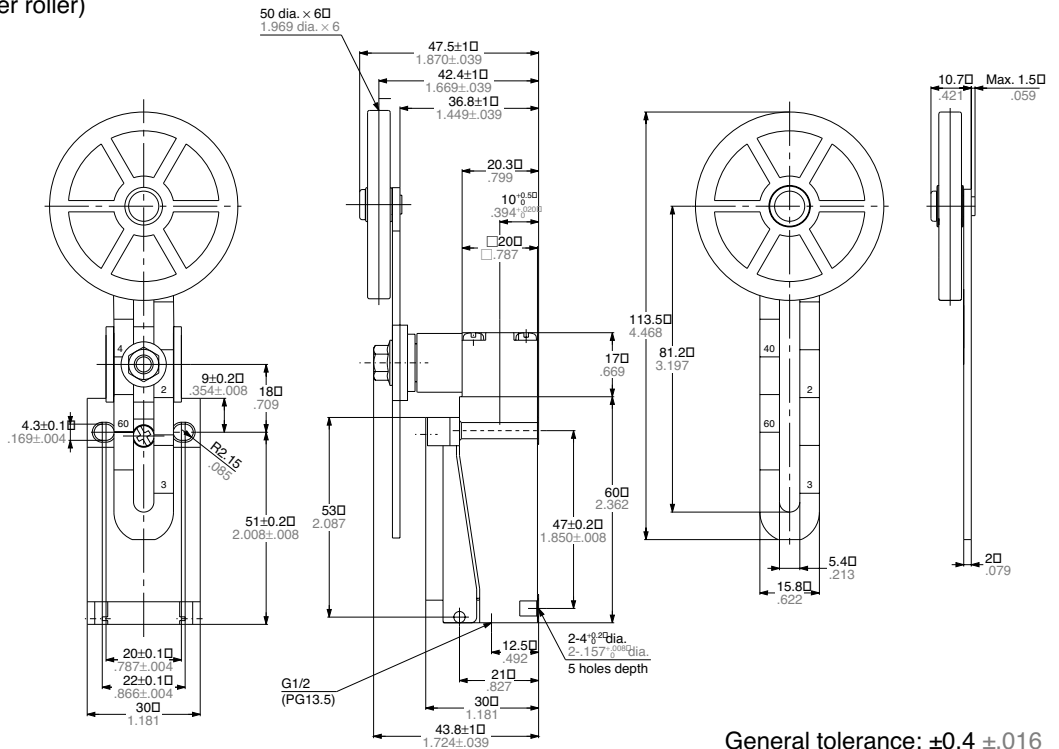

General tolerance: $\pm 0.4 \pm .016$

Roller arm type



AZD1004
AZD1054

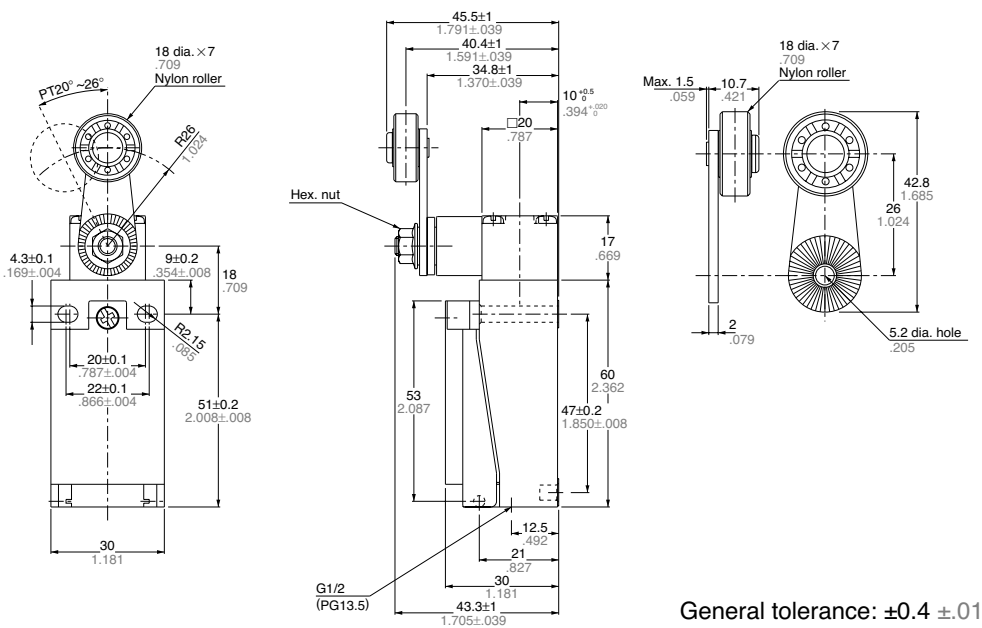

General tolerance: $\pm 0.4 \pm .016$

DL (AZD1)

Adjustable rod (2.6 dia.)

mm inch



AZD1007
AZD1057

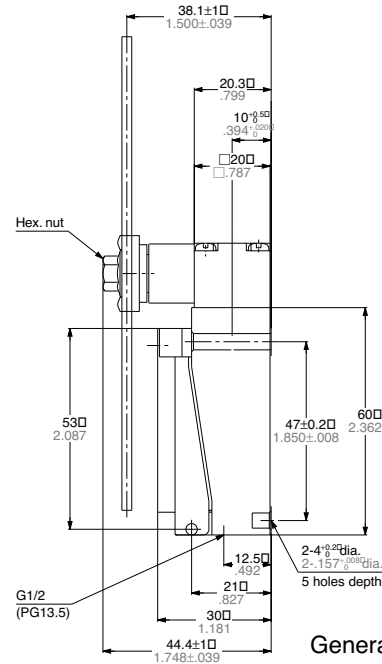
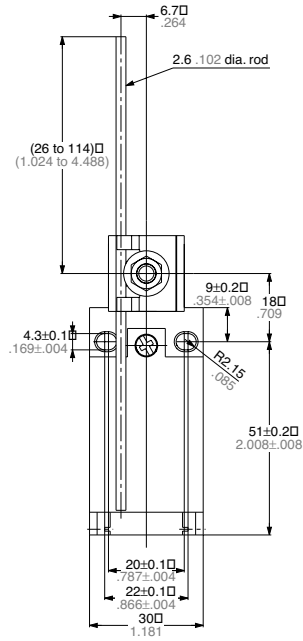

General tolerance: ±0.4 ±.016

Adjustable roller arm type



AZD1008
AZD1058

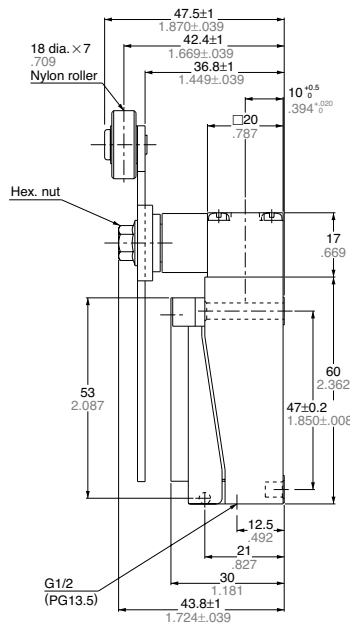
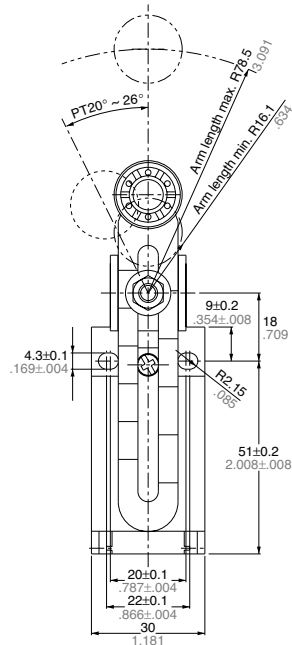

General tolerance: ±0.4 ±.016

Roller lever (vertical action)



AZD1009
AZD1059

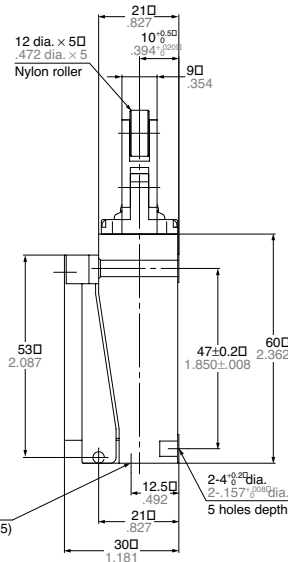
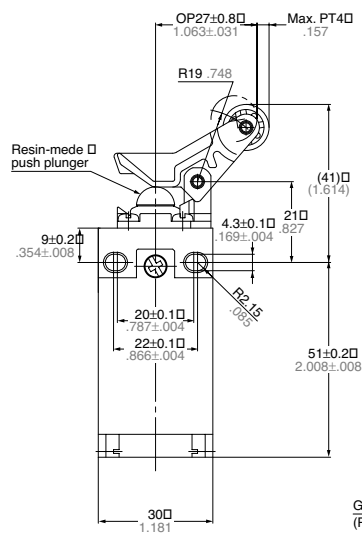

General tolerance: ±0.4 ±.016

Conduit connector (PF type)



AZD1830

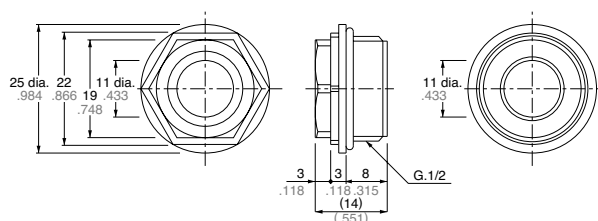

mm inch

Rubber seal inside diameter	Adaptable cable outer diameter	
	Min.	Max.
9 dia. (.354)	7.5 dia. (.295)	9.5 dia. (.374)
11 dia. (.433)	9 dia. (.354)	11 dia. (.433)

General tolerance: $\pm 0.5 \pm .020$

Arm Setting Position

The roller arm of the arm types (AZD1003, AZD1004, AZD1008, AZD1053, AZD1054 and AZD1058) can be set in any position at 15° intervals. Loosen the arm fastening hex. nut, reposition the arm, and retighten the hex. nut. When doing so tighten the hex. nut with the arm secured to the unit. Tightening without securing may cause damage. Also, the same is true of the variable rod types (AZD1007 and AZD1057).

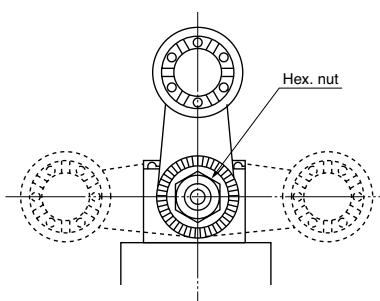

Roller Direction

The roller of the arm types (AZD1004, AZD1008, AZD1054 and AZD1058) can be mounted on the front and rear (dotted line in the figure) sides of the switch, as shown below. (Positioned on the front side at delivery.)

To set the roller on the rear side, remove the arm fastening hex. nut, and reinsert the arm so as to face the roller in the rear direction. Then, retighten the hex. nut.

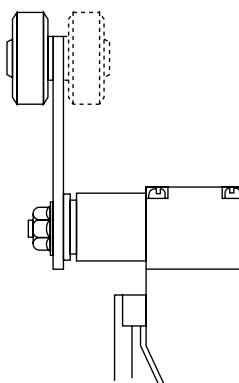

Roller Lever Direction

AZD1000, AZD1009, AZD1050 and AZD1059 type is move a detection object in the D direction as shown below. Be sure not to move the object oppositely. If the opposite direction is required, change the direction of the lever.

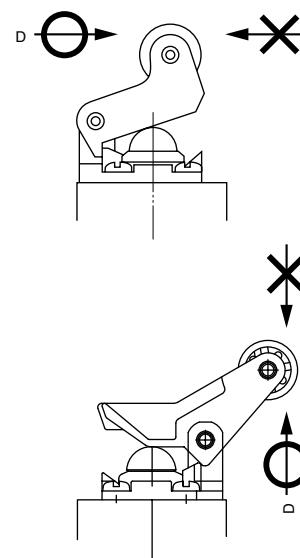

Head Direction

The head of the arm types (AZD1003, AZD1004, AZD1008, AZD1053, AZD1054 and AZD1058) can be set in any of four directions at 90° intervals, but not in any other intermediate directions. Loosen four screws on the upper side of the head, and set the head in a desired direction, and retighten them at a torque of 0.20 to 0.39 N·m. Be careful not to use too much strength when tightening as this will cause the threads to strip. Also, the same is true of the variable rod types (AZD1007 and AZD1057).

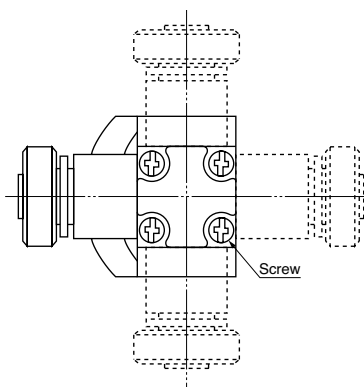

Adjustable Arm Length

To adjust the length of the adjustable arm of AZD1008 and AZD1058, slightly loosen the arm fastening hex. nut, and adjust the length.

The adjustable arm is graduated in two kinds of length units. Use these indications as the reference during adjustment.

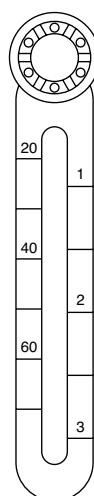

The roller lever can be set in two directions at 180° intervals. (Even though it can be also set in the 90° direction, the mounting surface will project.) Remove the four lever base fastening screws, turn the lever together with the lever base in 180°, and retighten the four screws at a torque of 0.20 to 0.39 N·m {2 to 4 kg·cm}.

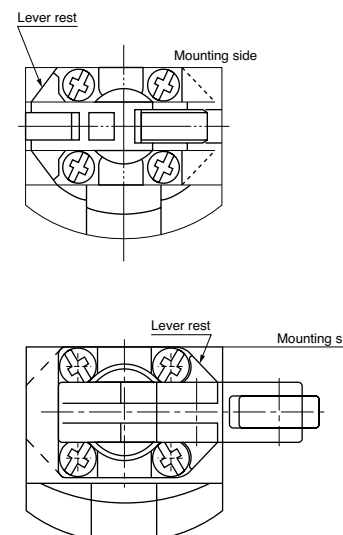

Open and close the cover

For the adjustable roller arm type, the cover will not open and close since it contacts the adjustable arm. Either extend the arm fully or remove the arm, then open or close the cover. Also, the same is true of the variable rod types (AZD1007 and AZD1057).

Adjustable Rod Length

To adjust the length of the variable rod, slightly loosen the hex. nut that is securing the rod and then change the length. After making the change, tighten the hex. nut keeping within a tightening torque of 0.98 and 1.37 N·m. Over tightening might damage the rod presser plate.

Mounting

- 1) When mounting, use washers (to prevent loosening) and tighten at a torque of 0.49 to 0.69 N·m {5 to 7 kg·cm}.
- 2) To securely mount the switch, not only fasten the main switch body only with two mounting holes, but also provide two 4^{+0.2}_{-0.35} mm dia. and max. 5mm .197inch high projections and insert them into the holes on the bottom of the main switch body.

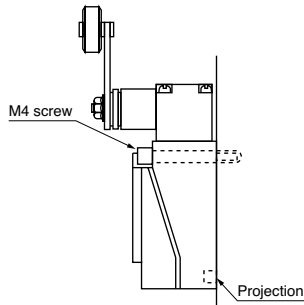

• Mounting dimensions

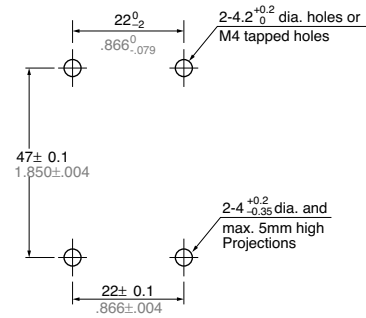

CAUTIONS

- 1) This model uses silver terminals. Therefore, if used at relatively low frequencies for long periods of time, or if used with very small loads, the oxidation that forms on the contact surfaces will not wear away and eventually cause improper contact. For such applications, use limit switches with gold/metal contacts (e.g. VL limit switches) or ones meant for small loads (e.g. HL limit switches).
- 2) This switch is not designed for underwater use. Do not use the unit underwater.
- 3) Do not use the switch where it may come in direct contact with organic solvents, strong acids, strong alkaline liquids or steam, or in atmospheres containing flammable or corrosive gases.
- 4) For the arm type (roller arm type, adjustable roller arm type), the arm can only be set at 15° interval.
- 5) To improve reliability during actual use, it is recommended that the operation be checked under installation conditions.
- 6) If OT is too big, the life of limit switch will be shortened switching friction. Use it with enough margin of OT. 70% of OT standard value will be good for use.
- 7) Do not use the switch in a silicon atmosphere. Case should be taken where organic silicon rubber, adhesive, sealing material, oil, grease or lead wire generates silicon.

Adaptable crimp terminal (Bare terminal) mm inch

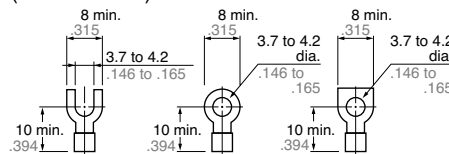

(Terminal with insulating grip)

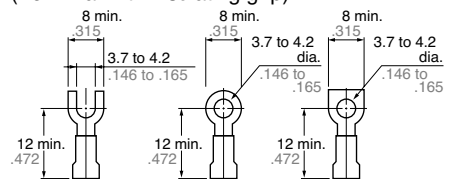

When crimp terminals are used.

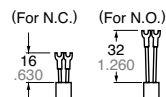

- 8) When wiring, do not connect the lead wires directly to the terminals, but use the crimp terminals and tighten them to a torque of 0.39 to 0.59 N·m {4 to 6 kg·cm}.
- 9) After wiring, when attaching the cover to switch body, be careful that the cover seal rubber is set normally on it and tighten the screw to a torque of 0.20 to 0.39 N·m {2 to 4 kg·cm}. If tighten the screw strongly, the thread is broken.
- 10) Safety mechanism is adopted which secures positive break under such abnormal conditions like contact welding, spring break, etc. In case of using the safety mechanism which breaks welded N.C. contact, conform to the conditions as shown below.

(For the value below of adjustable rod, the length of the rod shows the value when length of rod is set at 26 mm same as the roller arm. The value of adjustable roller arm (50 dia. rubber roller) type shows the value when arm length is set at 40 mm.)

	Actuator movement	Required force (Min.)
Push plunger Roller plunger	Approx. 3.5mm .138 inch	Approx. 29.4 N
Roller arm Adjustable rod Adjustable roller arm (50 dia. rubber roller)	Approx. 45° Approx. 45°	9.8 N 6.4 N
Roller lever type	Approx. 7 mm .276 inch	19.6 N

- 11) To protect against entry of foreign matter from the outside, we recommend sealing as much as possible using conduit connectors.
- 12) Avoid use in excessively dusty environments where actuator operation would be hindered.
- 13) When used outdoors (in places where there is exposure to direct sunlight or rain such as in multistory car parks) or in environments where ozone is generated, the influence of these environments may cause deterioration of the rubber material. Please consult us if you intend to use a switch in environments such as these.
- 14) Do not store in places where organic gas might be generated or in places of high dust content or high humidity.
- 15) Since the roller section of the roller arm (50 mm dia. rubber roller type)(AZD1003 and AZD1053) is heavy, the contacts may reverse due to inertia of the roller section which easily leads to erroneous operation. If there is a possibility of exposure to shock, please make considerations for safety, for example, by providing a redundant circuit so that danger can be avoided in the event that the contacts reverse and cause erroneous operation.

DESIGN OF OPERATING DOG

Roller arm type

(H: Hysteresis)

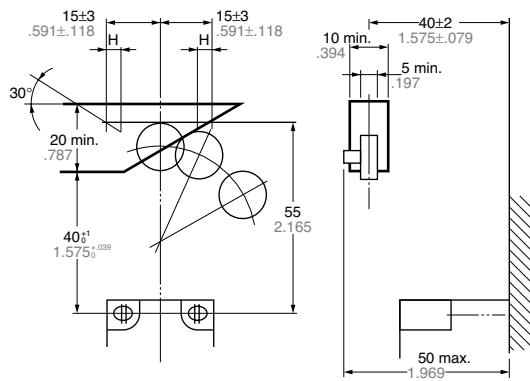

Roller plunger type

(H: Hysteresis)

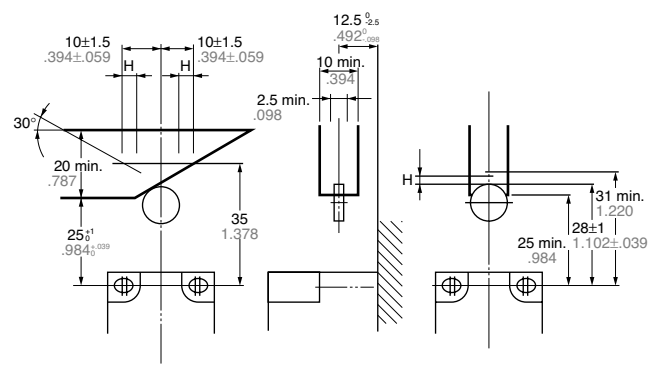

Roller lever type

(H: Hysteresis)

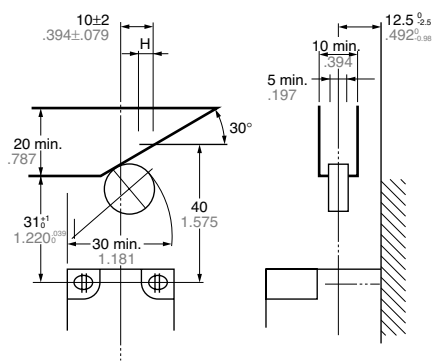

Push plunger type

(H: Hysteresis)

