

ASMT-QBB3-Nxxxx

Super 0.5W Power PLCC-4 Surface Mount LED Indicator

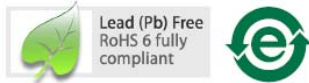

Data Sheet



Description

The Super 0.5W Power PLCC-4 SMT LED is Blue mid-Power PLCC-4 SMT LEDs using InGaN chip technology. The package can be driven at high current due to its superior package design. The product is able to dissipate the heat more efficiently compared to the Power PLCC-4 SMT LEDs. These LEDs produce higher light output with better flux performance compared to the Power PLCC-4 SMT LED.

The Super 0.5W Power PLCC-4 SMT LEDs are designed for higher reliability, better performance, and operate under a wide range of environmental conditions. The performance characteristics of these new mid-power LEDs make them uniquely suitable for use in harsh conditions such as in electronics signs and signals.

To facilitate easy pick and place assembly, the LEDs are packed in EIA-compliant tape and reel. Every reel is shipped in single intensity and color bin, to provide close uniformity.

Features

- Industry Standard PLCC 4 platform (3.2x2.8x1.9mm)
- High reliability package with enhanced silicone resin encapsulation
- High brightness with optimum flux performance using InGaN chip technologies
- Available in Blue color
- Available in 8mm carrier tape & 7 inch reel
- Wide viewing angle at 120 degree
- JEDEC MSL 2

Applications

- Electronic signs and signals
 - a. Decorative/Advertising Lighting
 - b. Channel Lettering
 - c. Signs Luminaire
 - d. RGB Backlighting

CAUTION: ASMT-QBB3-Nxxxx LEDs are Class 1C ESD sensitive. Please observe appropriate precautions during handling and processing. Refer to Avago Application Note AN-1142 for additional details.

Package Dimensions

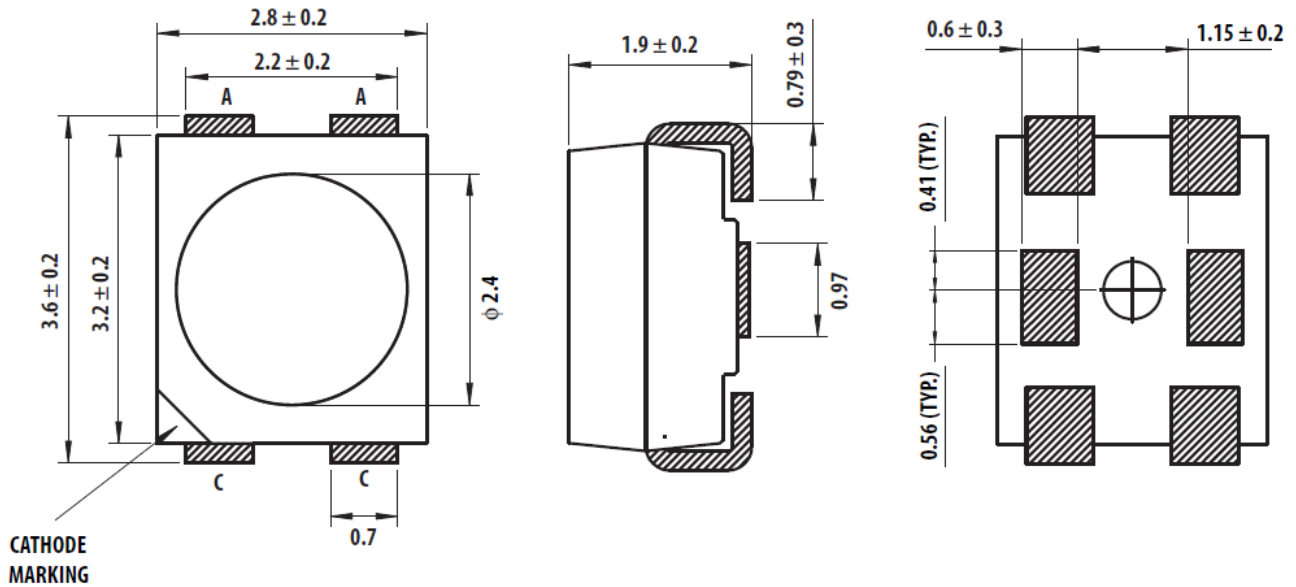

NOTE:

1. All Dimensions in millimeters.
2. Lead Polarity as Shown in Figure 13
3. Terminal Finish : Ag Plating
4. Encapsulation material : Silicone Resin

Figure 1. Package Drawing

Table 1. Device Selection Guide ($T_j = 25^\circ\text{C}$)

Color	Part Number	Luminous Flux, $\Phi_v^{[1]}$ (lm)		Test Current (mA)	Dice Technology
		Min Flux (mlm)	Max. Flux (mlm)		
Blue	ASMT-QBB3-NBDxE	5.50	11.50	150	InGaN

Notes:

1. Φ_v is the total luminous flux output as measured with an integrating sphere at mono pulse conditions.
2. IV Tolerance = $\pm 12\%$

Part Numbering System

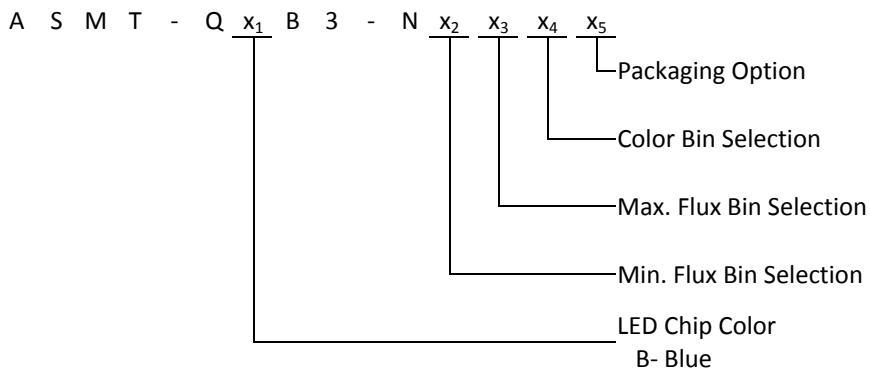

Table 2. Absolute Maximum Ratings (T_A = 25 °C)

Parameters	ASMT-QBB3
DC Forward Current ^[1]	150mA
Peak Forward Current ^[2]	300mA
Power Dissipation	570mW
Reverse Voltage, V _R @ 10μA	4 V
Junction Temperature	125 °C
Operating Temperature	- 40 °C to + 120 °C
Storage Temperature	- 40 °C to + 120 °C

Notes:

1. Derate linearly as shown in Figure 6.
2. Duty Factor = 10%, Frequency = 1kHz

Table 3. Optical Characteristics (T_A = 25 °C)

Color	Part Number	Dice Technology	Peak Wavelength	Dominant Wavelength	Viewing Angle
			λ _{PEAK} (nm) Typ.	λ _D (nm) Typ.	2θ _½ ^[2] (Degrees) Typ.
Blue	ASMT-QBB3	InGaN	454.0	460.0	120

Notes:

1. θ_½ is the off-axis angle where the luminous intensity is ½ the peak intensity.

Table 4. Electrical Characteristics (T_A = 25 °C)

Part Number	Forward Voltage V _F (Volts) @ I _F = 150 mA ^[1]		Thermal Resistance Rθ _{JP} (°C/W)
	Typ.	Max.	
ASMT-QBB3	3.5	3.8	40

Notes:

1. Tolerance = ± 0.1V

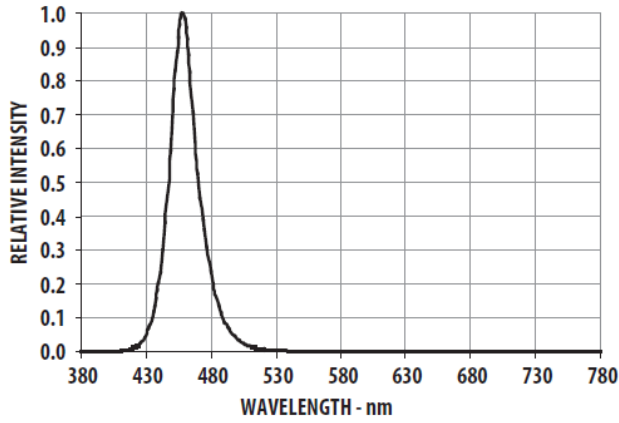

Figure 2. Relative Intensity Vs. Wavelength

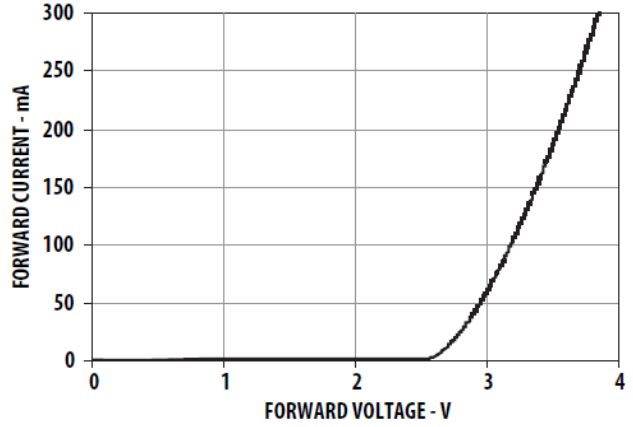

Figure 3. Forward Current Vs. Forward Voltage.

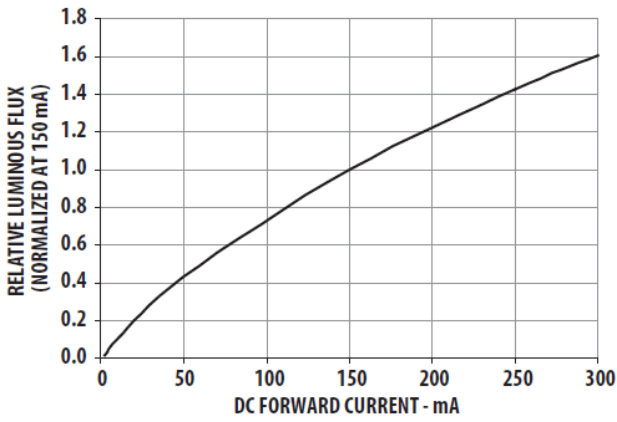

Figure 4. Relative Flux vs. Forward Current

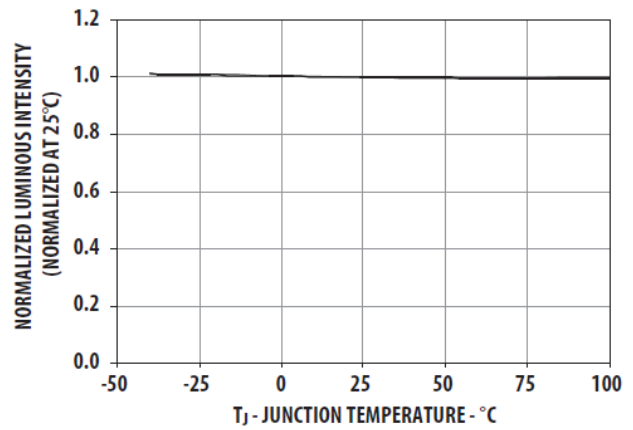

Figure 5. Relative Flux vs. Temperature

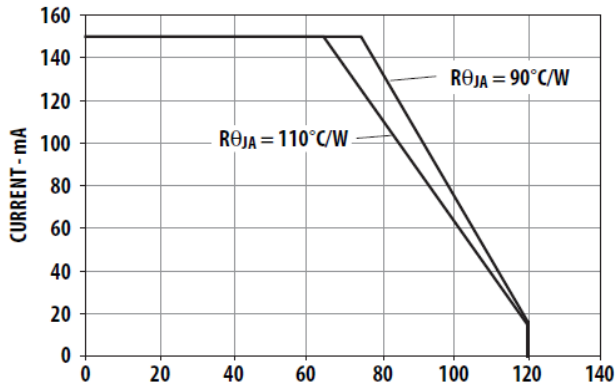

Figure 6a. Maximum Forward Current Vs. Ambient Temperature. Derated
Based on $T_{JMAX} = 125^{\circ}C$, $R_{J-A} = 110^{\circ}C/W$ & $90^{\circ}C/W$.

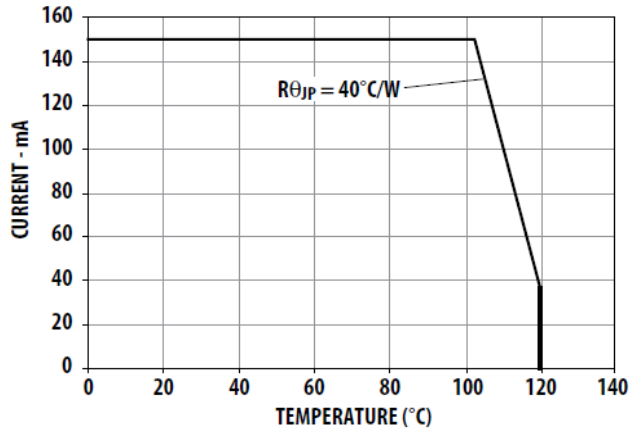

Figure 6b. Maximum Forward Current Vs. Solder Point Temperature. Derated
Based on $T_{JMAX} = 125^{\circ}C$, $R_{J-P} = 40^{\circ}C/W$.

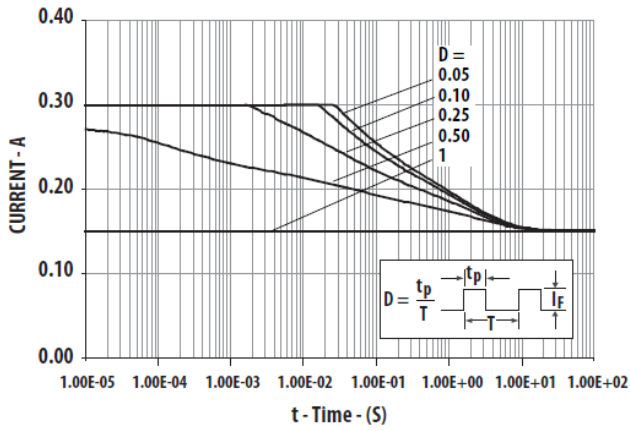

Figure 7a. Maximum Pulse Current Vs. Ambient Temperature. Derated Based on $T_A = 25^\circ\text{C}$, $R_{J-A} = 110^\circ\text{C/W}$.

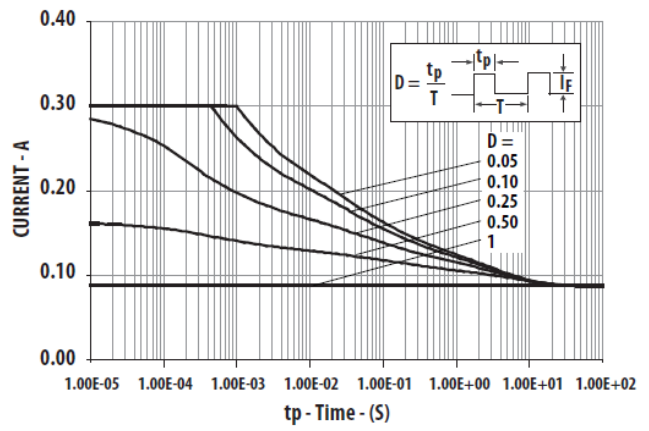

Figure 7b. Maximum Pulse Current Vs. Ambient Temperature. Derated Based on $T_A = 85^\circ\text{C}$, $R_{J-A} = 110^\circ\text{C/W}$.

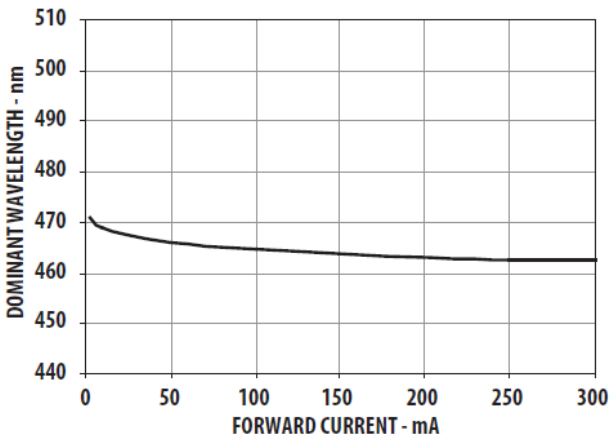

Figure 8. Chromaticity Shift Vs. Forward Current

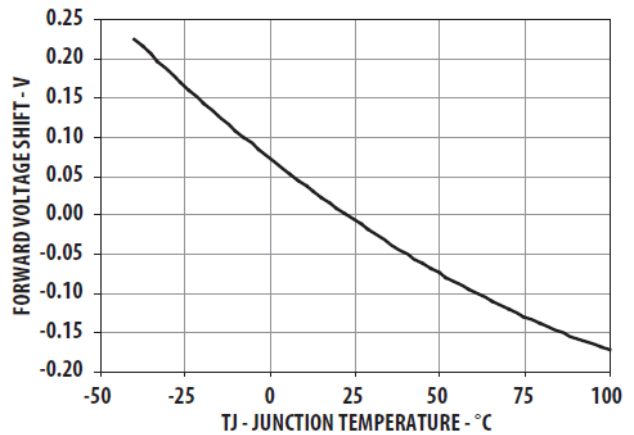

Figure 9. Forward Voltage Shift Vs. Temperature

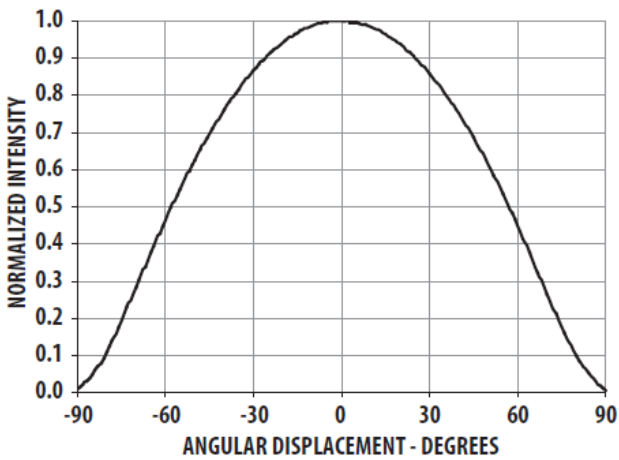
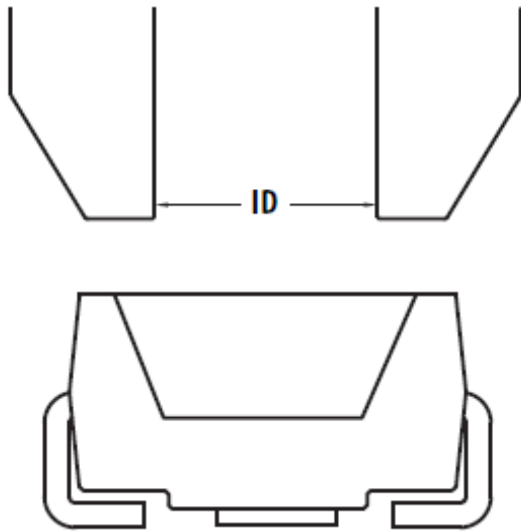
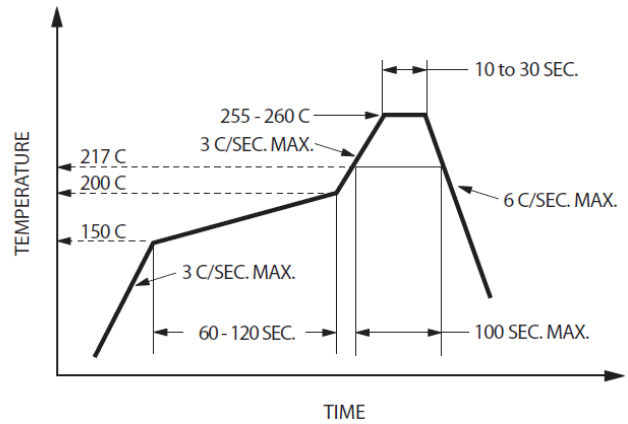

Figure 10. Radiation Pattern



Note: Diameter "ID" should be bigger than 1.7mm SMT LED Indicator Components

Figure 11. Recommended Pick and Place Nozzle Size



Note: For detail information on reflow soldering of Avago surface mount LEDs, do refer to Avago Application Note AN 1060 Surface Mounting

Figure 12. Recommended Pb-free Reflow Soldering Profile

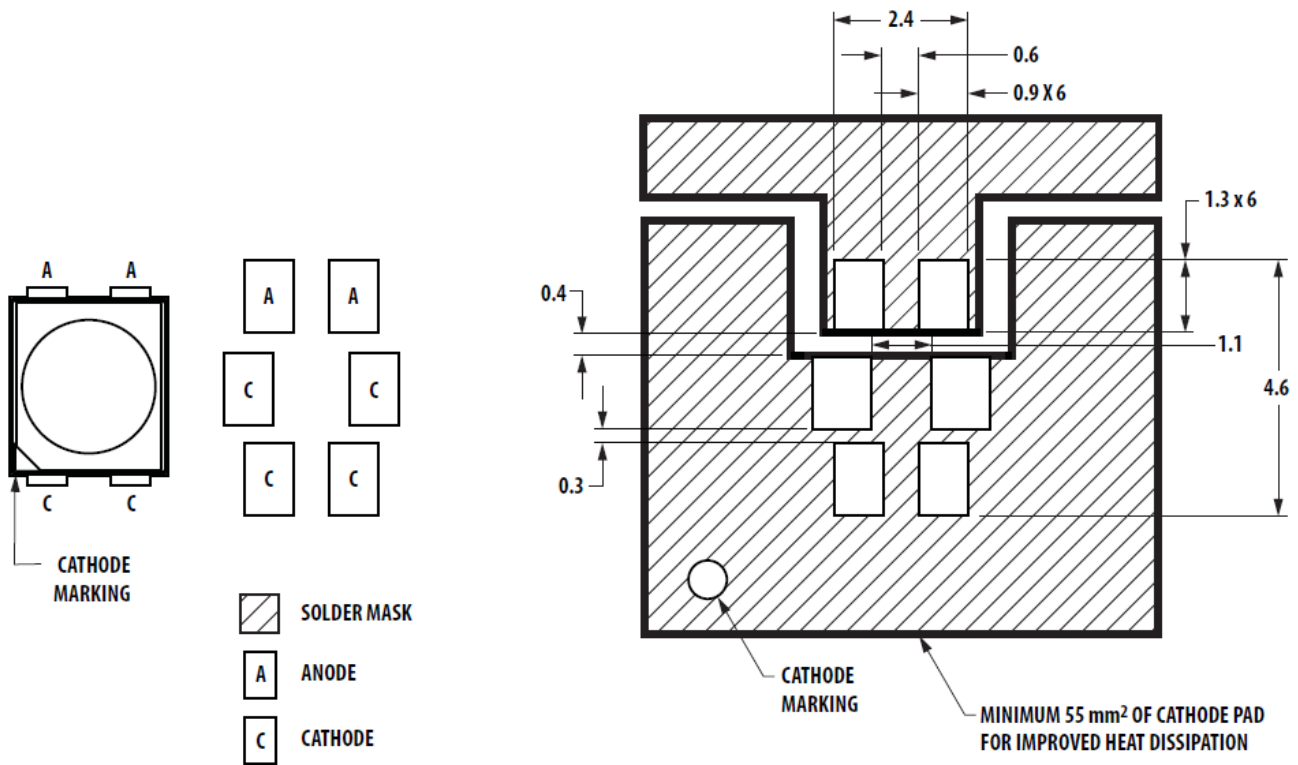

Figure 13. Recommended Soldering Pad Pattern

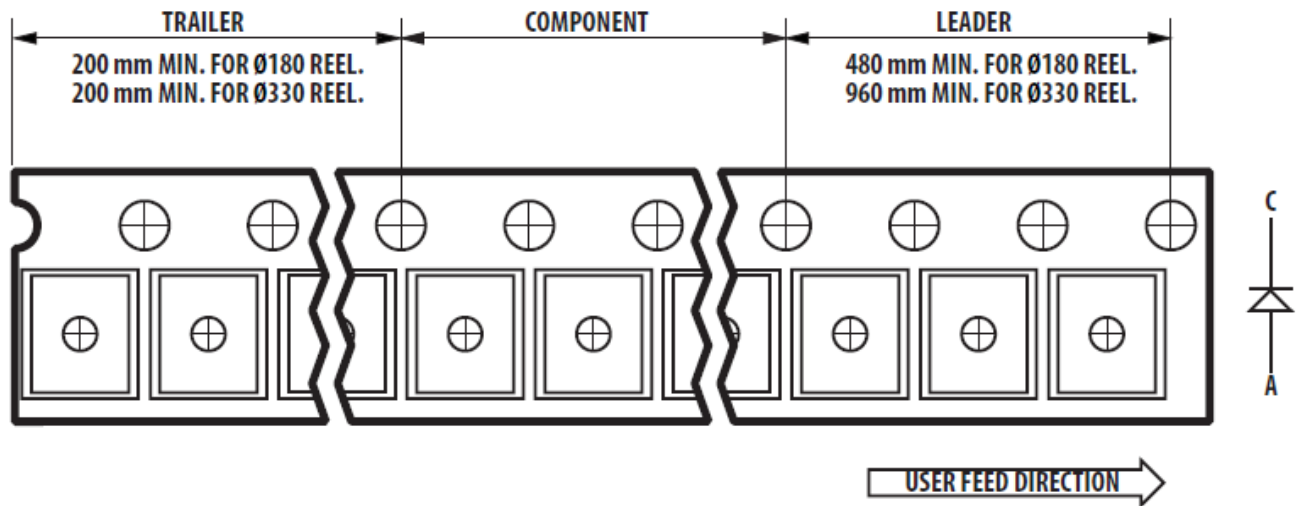
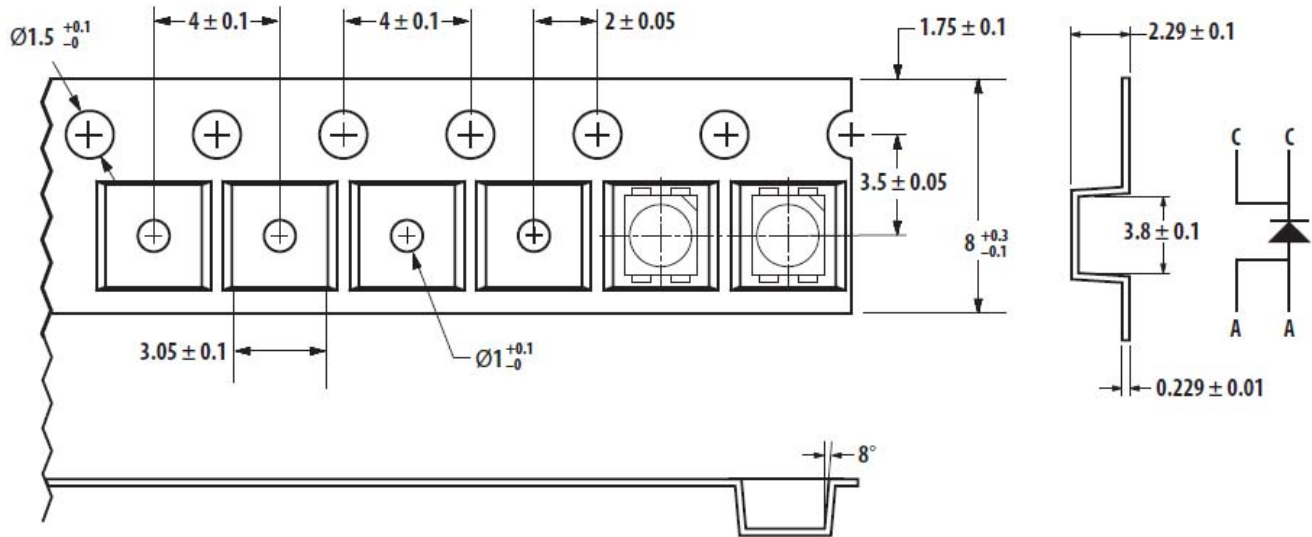

Figure 14. Tape Leader and Trailer Dimensions



ALL DIMENSIONS IN mm.

Figure 15. Tape Dimensions

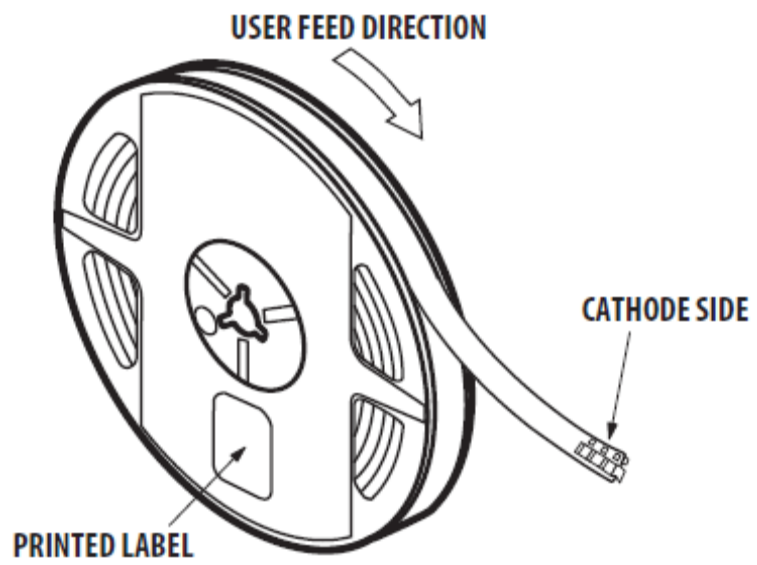

Figure 16. Reeling Orientation

Device Color (X₁)

B	Blue
---	------

Flux Bin Select (X₂X₃)

Individual reel will contain parts form one bin only

X ₂	Min Flux Bin
----------------	--------------

X ₃	Max Flux Bin
----------------	--------------

Flux Bin Limit

Bin ID	Min. (lm)	Max. (lm)
9	Special Flux Bin	
0	3.40	4.30
A	4.30	5.50
B	5.50	7.00
C	7.00	9.00
D	9.00	11.50
E	11.50	15.00
F	15.00	19.50
G	19.50	25.50
H	25.50	33.00
J	33.00	43.00
K	43.00	56.00
L	56.00	73.00

Tolerance of each bin limit = +/- 12%

Color Bin Select (X₄)

Individual reel will contain parts form one full bin only

X₄

0	Full Distribution
A	8 and 9 only
B	9 and 1 only
C	1 and 2 only
G	8, 9 and 1 only
H	9, 1 and 2 only
Z	Special binning

Color Bin Limits

Blue	Min. (nm)	Max. (nm)
8	450.0	455.0
9	455.0	460.0
1	460.0	465.0
2	465.0	470.0

Tolerance of each bin limit = +/- 1 nm

Vf Bin Limit

Bin ID	Min.	Max.
S4	2.90	3.20
S5	3.20	3.50
S6	3.50	3.80

Tolerance of each bin limit = +/- 0.1V

Packaging Option (X₅)

Option	Test Current	Package Type	Reel Size
E	150mA	Top Mount	7 inch

Handling Precaution

The encapsulation material of the product is made of silicone for better reliability of the product. As silicone is a soft material, please do not press on the silicone or poke a sharp object onto the silicone. These might damage the product and cause premature failure. During assembly or handling, the unit should be held on the body only. Please refer to Avago Application Note AN 5288 for detail information.

Moisture Sensitivity

This product is qualified as Moisture Sensitive Level 2 per Jedec J-STD-020. Precautions when handling this moisture sensitive product is important to ensure the reliability of the product. Do refer to Avago Application Note AN5305 Handling of Moisture Sensitive Surface Mount Devices for details.

A. Storage before use

- Unopen moisture barrier bag (MBB) can be stored at <40°C/90%RH for 12 months. If the actual shelf life has exceeded 12 months and the HIC indicates that baking is not required, then it is safe to reflow the LEDs per the original MSL rating.
- It is not recommended to open the MBB prior to assembly (e.g. for IQC).

B. Control after opening the MBB

- The humidity indicator card (HIC) shall be read immediately upon opening of MBB.
- The LEDs must be kept at <30°C / 60%RH at all time and all high temperature related process including soldering, curing or rework need to be completed within 1 year.

C. Control for unfinished reel

- For any unuse LEDs, they need to be stored in sealed MBB with desiccant or desiccator at <5%RH.

D. Control of assembly boards

- If the PCB soldered with the LEDs is to be subjected to other high temperature processes, the PCB need to be stored in sealed MBB with desiccant or desiccator at <5%RH to ensure no LEDs have exceeded their floor life of 1 year.

E. Baking is required if

- "60%" HIC indicator is NOT Green.
- The LEDs are exposed to condition of >30°C/60% RH at any time.
- The LEDs floor life exceeded 1 year.

Recommended baking condition: 60°C for 20 hours.

For product information and a complete list of distributors, please go to our web site:

www.avagotech.com

Avago, Avago Technologies, and the A logo are trademarks of Avago Technologies, Pte. in the United States and other countries.

July 25, 2012

