



Our *passion* is enclosures.

An entirely new concept.

ROLEC aluDISC. The round enclosure.
Roundly complete.





There are industries in which everything is round. Tanks. Pipes. Lamps. Displays. Instruments.

Only the enclosures are square. Because round ones did not exist. Until now!

Now there's aluDISC from **ROLEC** Round! Roundly complete!

With aluDISC ROLEC is once again setting entirely new benchmarks. Until now leak proof enclosures made from metal that were round and suitable for harsh environmental conditions did not come "off the shelf". Anyone who required round enclosures had to have these developed and manufactured specially.

The ROLEC idea: Standardised enclosures to meet this demand. Not so simple: Space for fixing channels and lid fixing screws is provided even though totally round bodies have not flat surfaces upon which to mount cable glands and connectors.

Perspectives of the n





The watch as an example

The experienced ROLEC designers found the solution. There were many ideas, which went on to become proto-types before being once again rejected. ROLEC has known for a long time: Concepts follow on from rejects. Only thus can one really get round the matter.

new enclosure creation



The brilliant ROLEC principle as with aluCAGE: Enclosure attachment with closed lids and design covers.

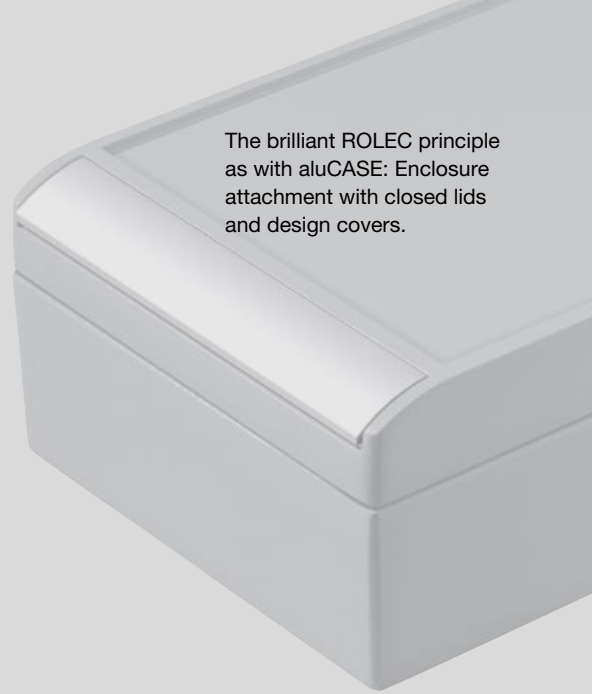

The perfect symbiosis of form and function.

ROLEC aluDISC. Perfect design.
Perfect technology. Round.

Advantages at a glance



Integrated recesses for membrane keypads.



Enclosure attachment with closed lids.



Design covers for the perfect look.



Economical lid support.



Attachment domes in the enclosures and lids for components.



Covers from transparent polycarbonate as protection for membrane keypads and against manipulation.

The design

The unusual shape of the new enclosure opened up new possibilities with respect to the design. So that a product came into being with an attractive design.

Likewise "round" the technology. With aluDISC all of the technical achievements of the aluCAGE range, introduced a few years previously, came into effect.

Cover for frontal installations

Users often wish to protect the integrated membrane keypad against unauthorised access. Another requirement is the protection of integrated actuation elements against environmental influences. ROLEC developed a cover from transparent polycarbonate.

Approvals:





aluDISC

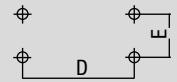
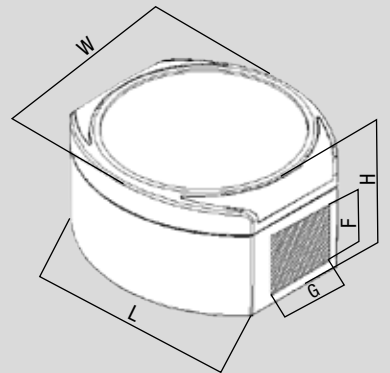

Installation dimensions

The delivery program



AR 080

AR 100

AR 120

AR 160

aluDISC range overview

Type	Mat. No	L	W	H	D	E	F	G	g	M	D	EMV	L	SH	DH	Plus
AR 080	280.080.000	110	97	55	89,8	45,2	27,5	12,5	410	●	□	●	●	○	○	●
AR 100	280.100.000	130	119	65	99,4	68,4	40,5	27,5	590	●	□	●	●	○	●	●
AR 120	280.120.000	150	139	80	116,5	80	55,5	40	820	●	□	●	●	●	●	●
AR 160	280.160.000	190	179	90	155,5	99	65,5	57,5	1190	●	□	●	●	○	●	●

□ Standard ● Available ○ Not available

Technical information

Enclosure

Die-cast aluminium
EN AN-44300 DIN EN 1706
(GD AL SI 12 / DIN 1725)
1° mould slope for casting
ejection, internal measures
diminishing circulatory towards
enclosure bottom by 1°.

Lid screws

Stainless steel 1.4567, captive.

Integrated recess

1.7 mm recess in the lid for
membrane keypad or front
plates, membrane dimension-
al data for standard powder
coating.

Optional cover

Cover with hinge mechanism
from transparent polycarbonate
(PC) UV-stabilised, sealable.
UL 94 V-2 – 0.36 ~ 1.9 mm,
HB > 1.9 mm.

Optional lid support

Screw hinge, lid screw with
plastic element from stainless
steel 1.4567 and polyamide
(PA6).

Clip-on design cover

Plastic polyoxymethylene
(POM) in RAL 7016,
anthracite grey.

Fixtures

Attachment domes in the top
and bottom section ensure
secure fastening of installed
components.

Ingress protection







IP 66 / EN 60529
IP 67 / EN 60529
IP 69K DIN 40050 (optional)

Gasket

Silicone gasket
(-50°C bis +140°C)
Optional: Chloroprene gasket
(-30°C bis +90°C)

Surface

Powder coated in RAL 7035,
light grey,
optional: Special colours

-  **M** Mounting plates
-  **D** Silicone gasket
-  **EMV** Shielding
-  **L** Corrosion proof coating
-  **SH** Cover
-  **DH** Lid support
-  **PLUS** Protection class IP 69K

ROLEC Attachment and installation dimensions

aluDISC

AR 080

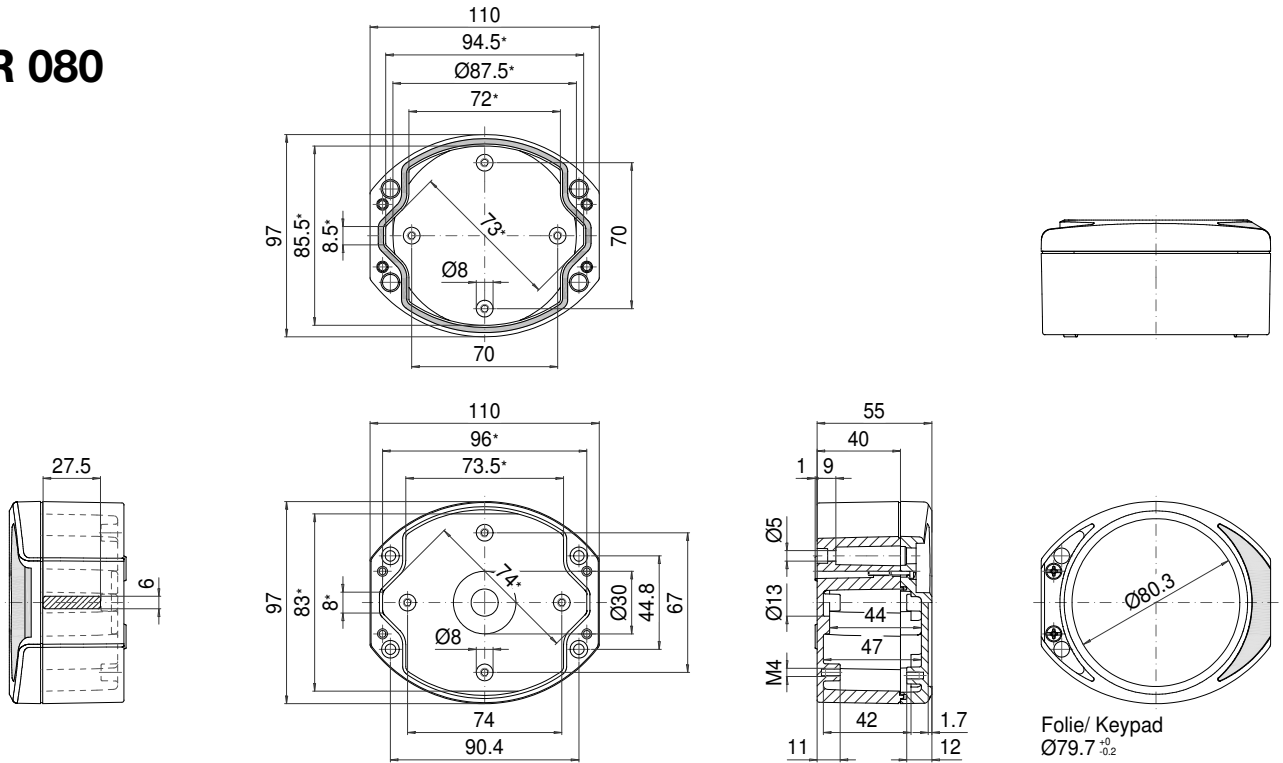

AR 100

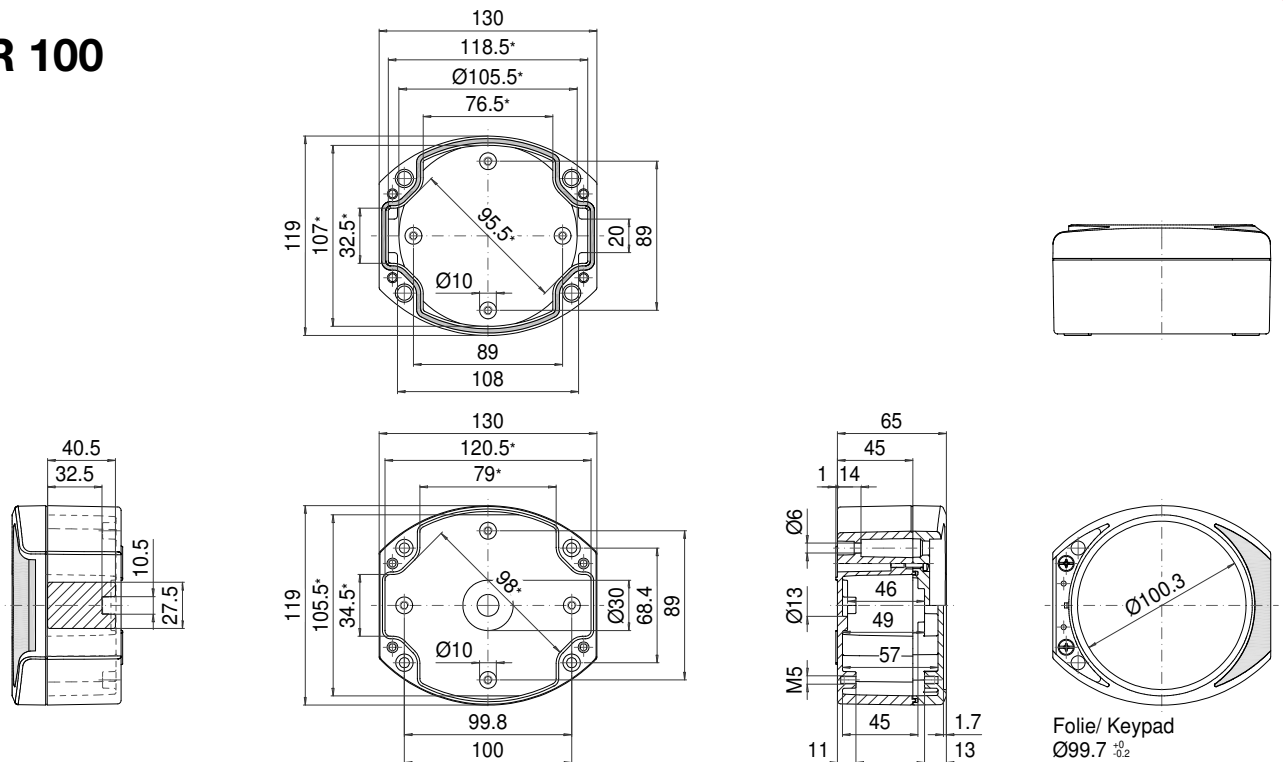

AR 120

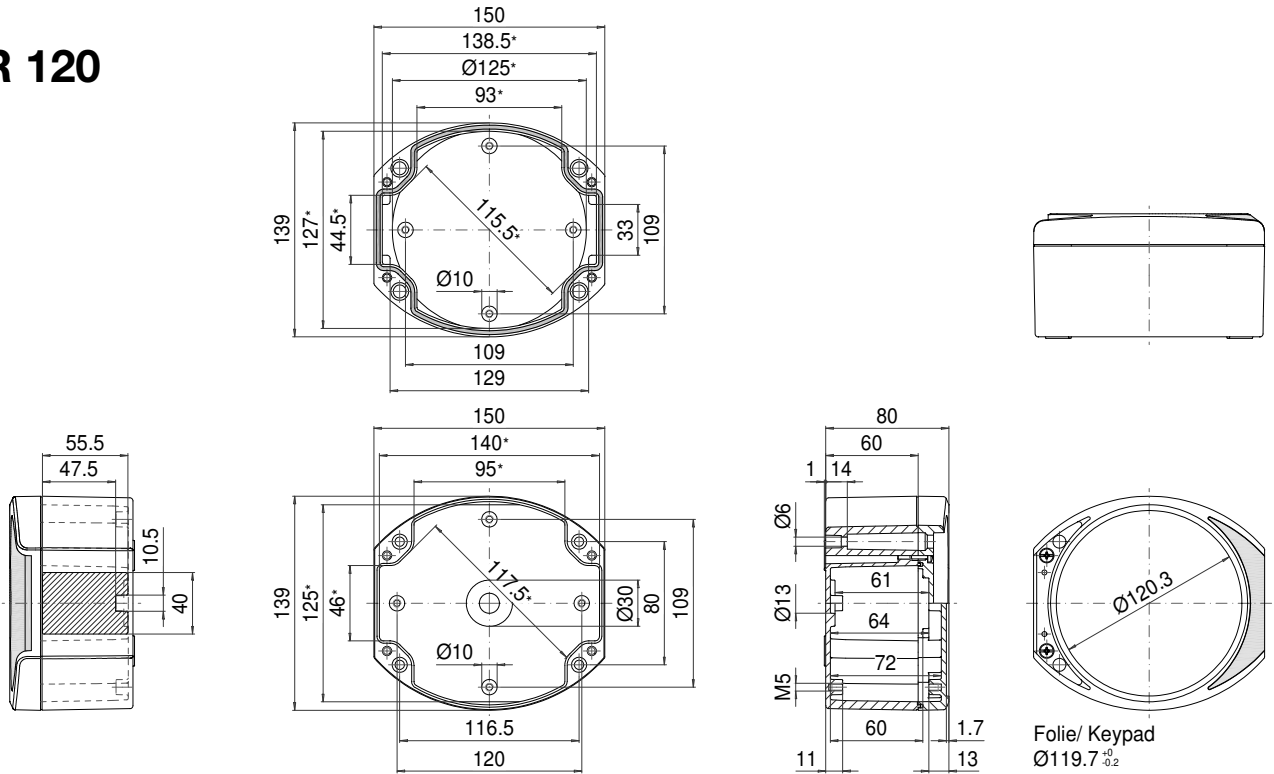

AR 160

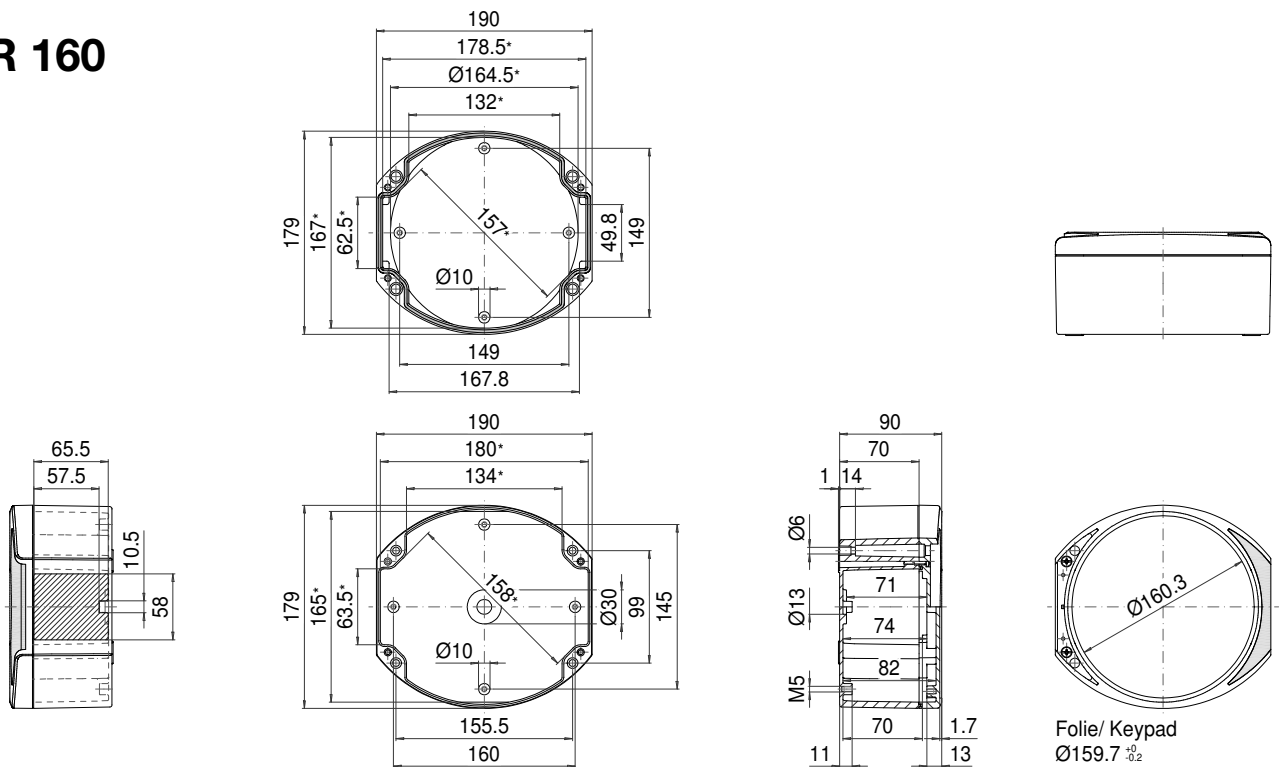



Our *passion* is enclosures.

Just-in-time. Ready for installation.

- Drilled.
- Milled.
- Engraved.
- Printed.
- Powder coated.
- Wet painted.
- Equipped.
- Assembled.
- Delivered.

ROLEC
Gehäuse-Systeme GmbH
Kreuzbreite 2
31737 Rinteln

Fon +49 (0) 57 51/ 40 03-0
Fax +49 (0) 57 51/ 40 03-50

info@rolec.de
www.rolec.de

