

Features

- Close responsively to the human eye spectrum
- Light to Current, analog output
- Good output linearity across wide illumination range
- Low sensitivity variation across various light sources
- Operating temperature performance, -40°C to 85°C
- Wide supply voltage range, 1.8V to 5.5V
- Size : 2.0mm(L)*1.25mm(W)*0.8mm(H)
- RoHS compliant and Pb Free package

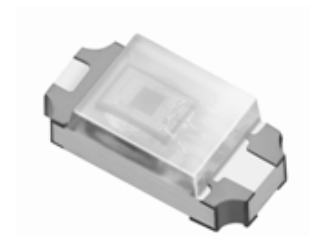

Description

The ALS-PDIC17-55C/TR8 is a low cost ambient light sensor, consisting of a photodiode and a current amplification IC. EVERLIGHT ALS series product is a good effective solution to the power saving of display backlighting of mobile appliances, such as the mobile phones, NB and PDAs. Due to the high rejection ratio of infrared radiation, the spectral response of the ambient light sensor is close to that of human eyes.

Applications

- Detection of ambient light to control display backlighting
 - Mobile devices – mobile phones, PDAs
 - Computing device – TFT LCD monitor for Notebook computer
 - Consumer device – TFT LCD TV, plasma TV, video camera, digital camera, toys
- Automatic residential and commercial management
- Automatic contrast enhancement for electronic signboard
- Ambient light monitoring device for daylight and artificial light
 - Street light, CCD/CCTV

Package Dimensions

Top view

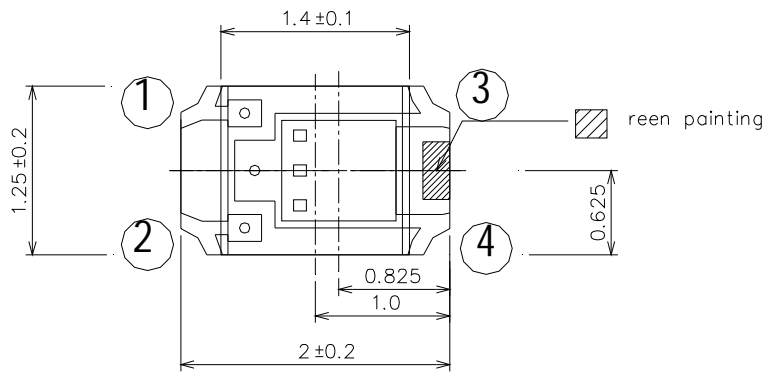

- ① Out
- ② Vcc
- ③ GND
- ④ GND

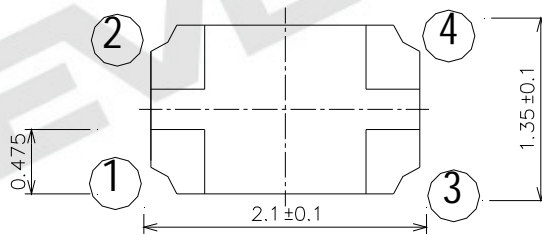
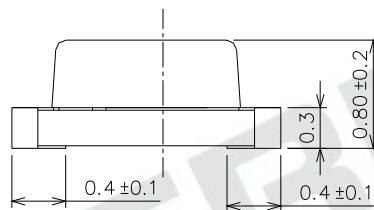

Bottom view

Unit: mm

Tolerances: ± 0.1 mm

Absolute Maximum Ratings (Ta=25°C)

Parameter	Symbol	Rating	Unit
Supply Voltage	V _{cc}	-0.5~6.0	V
Output Voltage	V _o	0 ~ V _{cc} -0.8	V
Output Photo Current	I _{PH}	0 ~ 5	mA
Operating Temperature Range	T _{opr}	-40 ~ +85	°C
Storage Temperature Range	T _{stg}	-40 ~ +100	°C
Soldering Temperature Range [Note1]	T _{sol}	260	°C
Human Body Model ESD	HBM	3000	V
Machine Model ESD	MM	300	V

Note1: For detail reflow time and the recommended temperature profile, please refer to page 8.

Recommended Operating Conditions (Ta=25°C)

Parameter	Symbol	Min.	Max.	Unit
Operating Temperature	T _{opr}	-40	+85	°C
Supply Voltage	V _{cc}	1.8	5.5	V

Electrical and Optical Characteristics (Ta=25°C)

Parameter	Symbol	Min.	Typ.	Max.	Unit	Test Condition	
Dark Current	I _D	-	-	100	nA	V _{CC} =3V E _v = 0Lux	
Light Current	I _{PH2}	27	-	54	μA	V _{CC} =3V; E _v = 100Lux [Note1] [Fig.2]	
	I _{PH3}	32.4	-	70.2	μA	V _{CC} =3V; E _v = 100Lux [Note2] [Fig.2]	
	I _{PH4}	270	-	540	μA	V _{CC} =3V; E _v =1000Lux [Note1] [Fig.2]	
Photocurrent Ratio	I _{PH3} / I _{PH2}	-	1.2	-	-		
Peak Sensitivity Wavelength	λ _p	-	590	-	nm		
Switching Time	Rise Time	tr	-	0.36	-	ms	V _{CC} =3V, R _L =27KΩ [Fig.4]
	Fall Time	tf	-	1.13	-	ms	
	Delay Time	td	-	2.30	-	ms	
	Storage Time	ts	-	0.69	-	ms	

Note:

1. White Fluorescent light (Color Temperature = 6500K) is used as light source. However, White LED is substituted in mass production.
2. Illuminance by CIE standard illuminant-A / 2856K, incandescent lamp.

Fig.1 Block Diagram

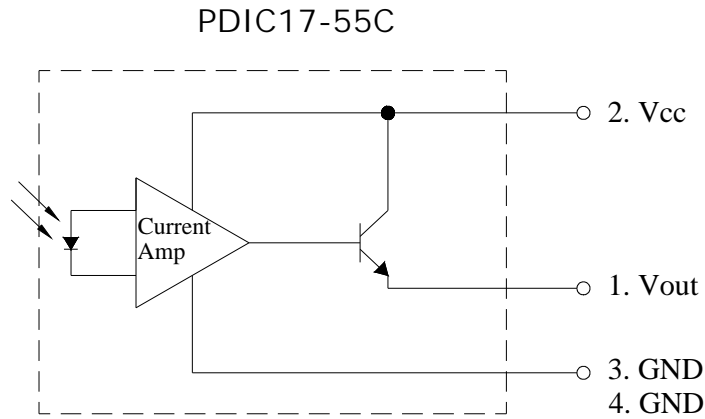

Fig.2 Measurement Method of Light Current

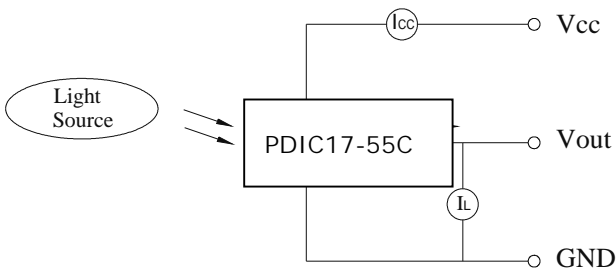

Fig.3 Measurement Method of Saturation Output Voltage

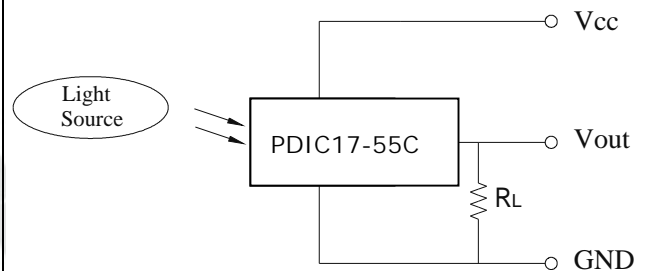
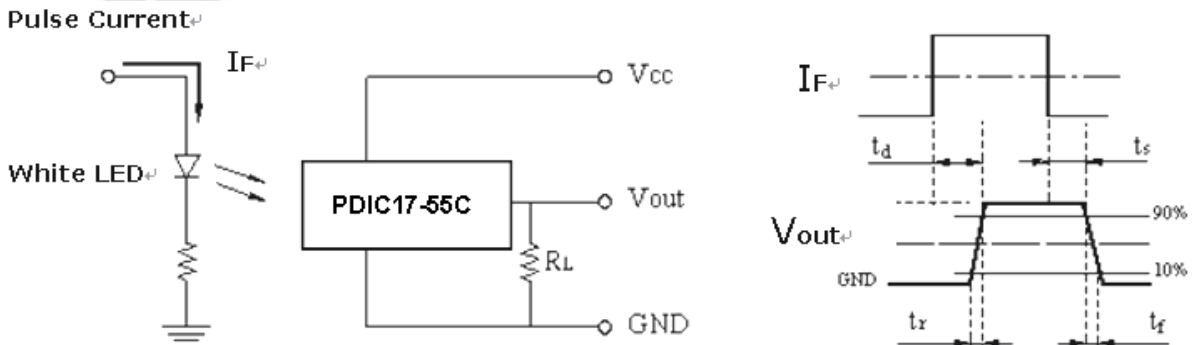
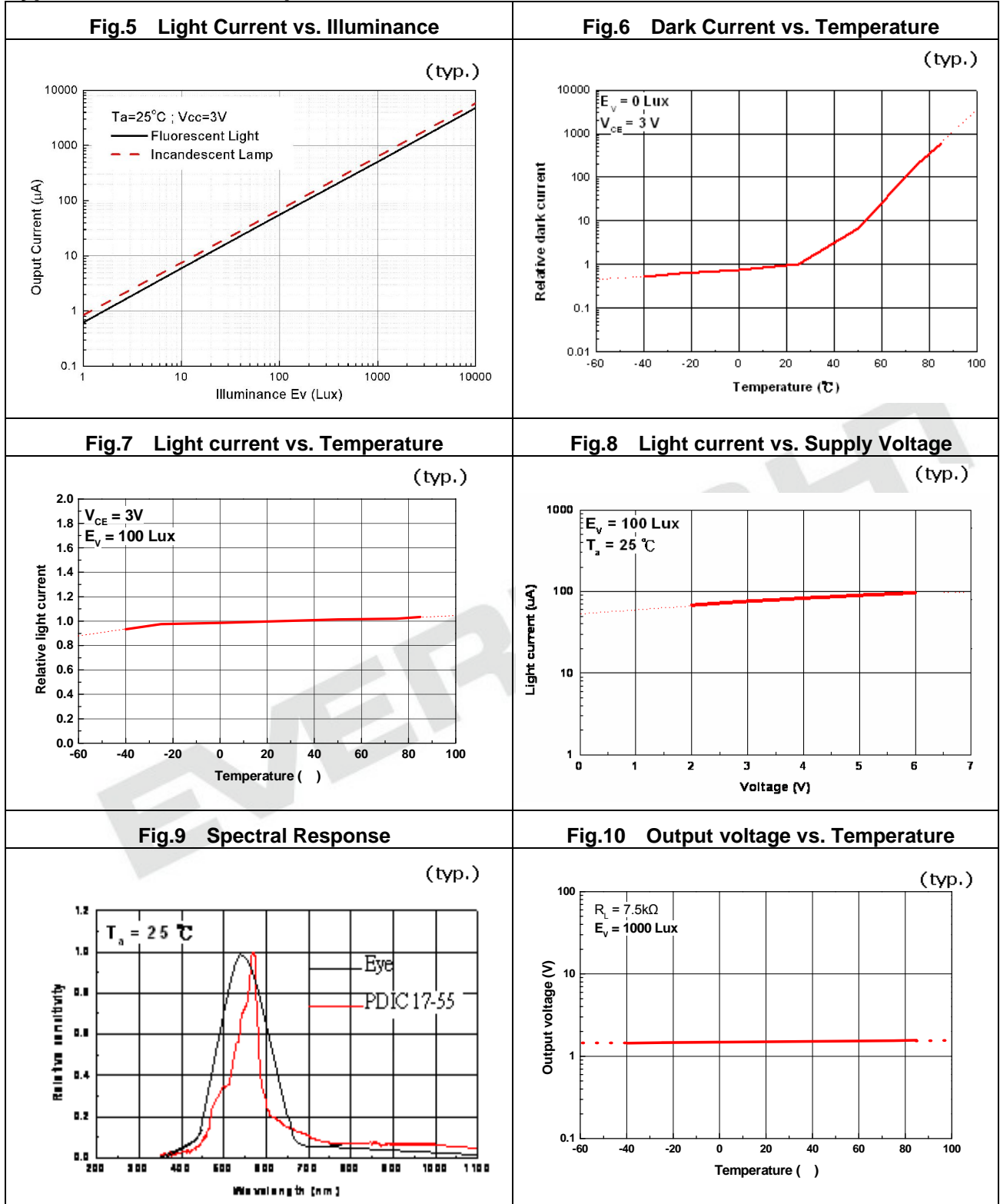

Fig.4 Switching Time Measurement Method



Typical Electrical and Optical Characteristics Curves



Converting Photocurrent to Voltage

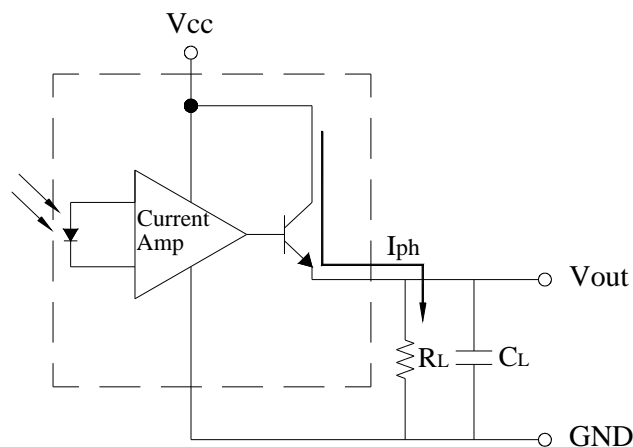

Note:

1. The output voltage (V_{out}) is the product of photocurrent (I_{PH}) and loading resistor (R_L)
2. A right loading resistor shall be chosen to meet the requirement of maximum ambient light, and output saturation voltage:

$$V_{out(max.)} = I_{out(max.)} \times R_L \quad V_{out(saturation)} = V_{cc} - 0.8V$$

3. To avoid 60Hz ripple from fluorescent lamps, we suggest that the time constant must be greater than 0.5 second:

$$R_L \times C_L \geq 0.5 \quad (\text{empirical data})$$

Recommended method of storage

Reflow Terms: JEDEC Level 4 Specification

Dry box storage is recommended as soon as the aluminum bag has been opened prevent moisture absorption. The following conditions should be observed, if dry boxes are not available:

- Storage temperature 10 to 30
- Storage humidity 60%RH max

After more than 72 hours under these conditions moisture content will be too high for reflow soldering. In case of moisture absorption, the devices will recover to former condition by drying under the following condition:

- 192 hours at 40 +5 -0 and 5%RH (dry air / nitrogen), or
- 96 hours at 60 +5 and < 5%RH for all device containers, or
- 24 hours at 125 +5 not suitable for reel or tubes

ESD Precaution:

Proper storage and handing procedures should be followed to prevent ESD damage to the devices especially when they are removed from the Anti-static bag. Electro-Static Sensitive Devices warning labels are on the packing.

Recommended Solder Profile

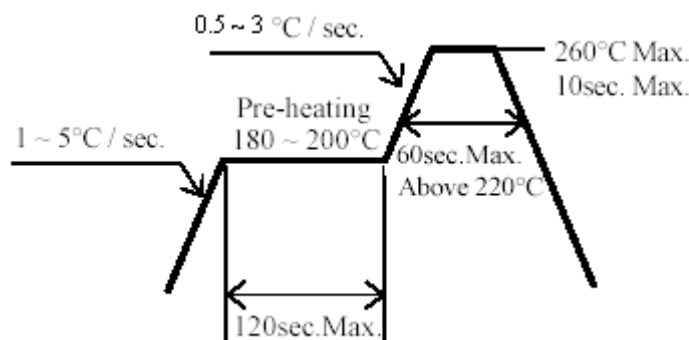

Notice:

- (1) Reflow soldering should not be done more than two times.
- (2) When soldering, do not put stress on the devices during heating.
- (3) After soldering, do not warp the circuit board.

Soldering Iron

Each terminal is to go to the tip of soldering iron temperature less than 350 for 3 seconds within once in less than the soldering iron capacity 25W. Leave two seconds and more intervals, and do soldering of each terminal. Be careful because the damage of the product is often started at the time of the hand solder.

Repairing

Repair should not be done after the device have been soldered. When repairing is unavoidable, a double-head soldering iron should be used (as below figure). It should be confirmed beforehand whether the characteristics of the device will or will not be damaged by repairing.

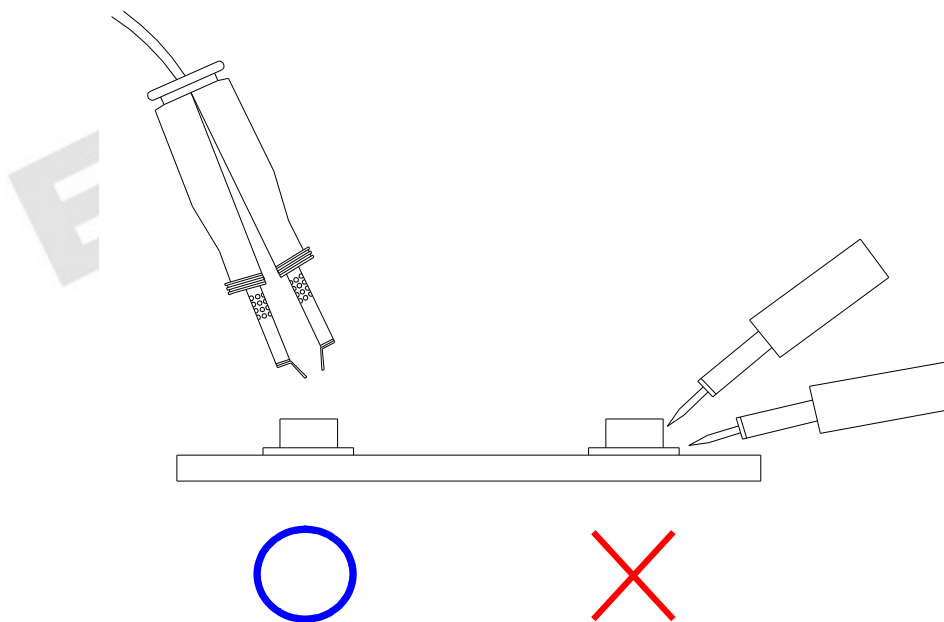

Packing Quantity Specification

3000 PCS/ 1 Reel

Label Format

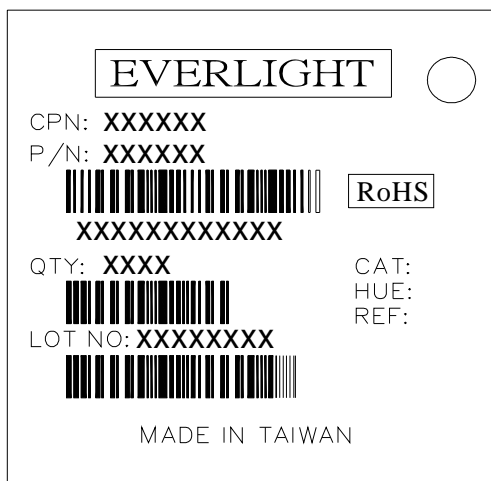

Reel Dimensions

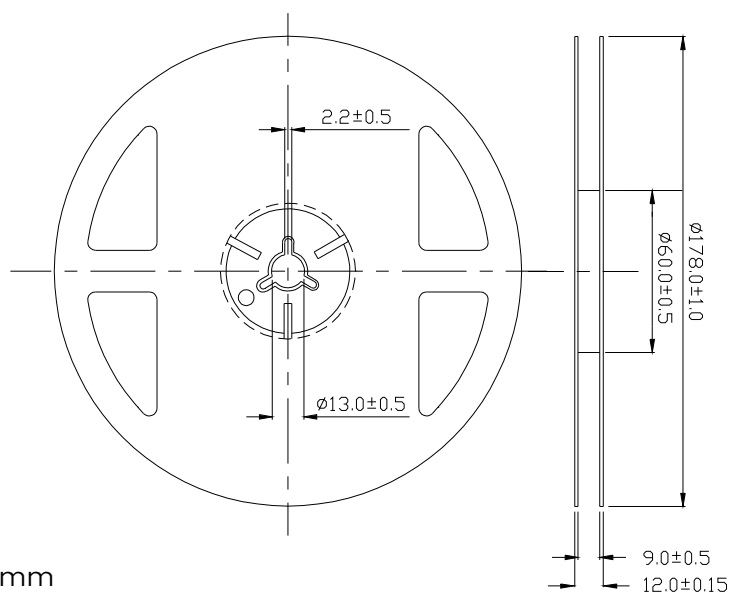

Unit: mm

Tolerance: ± 0.1mm

Tape Dimensions

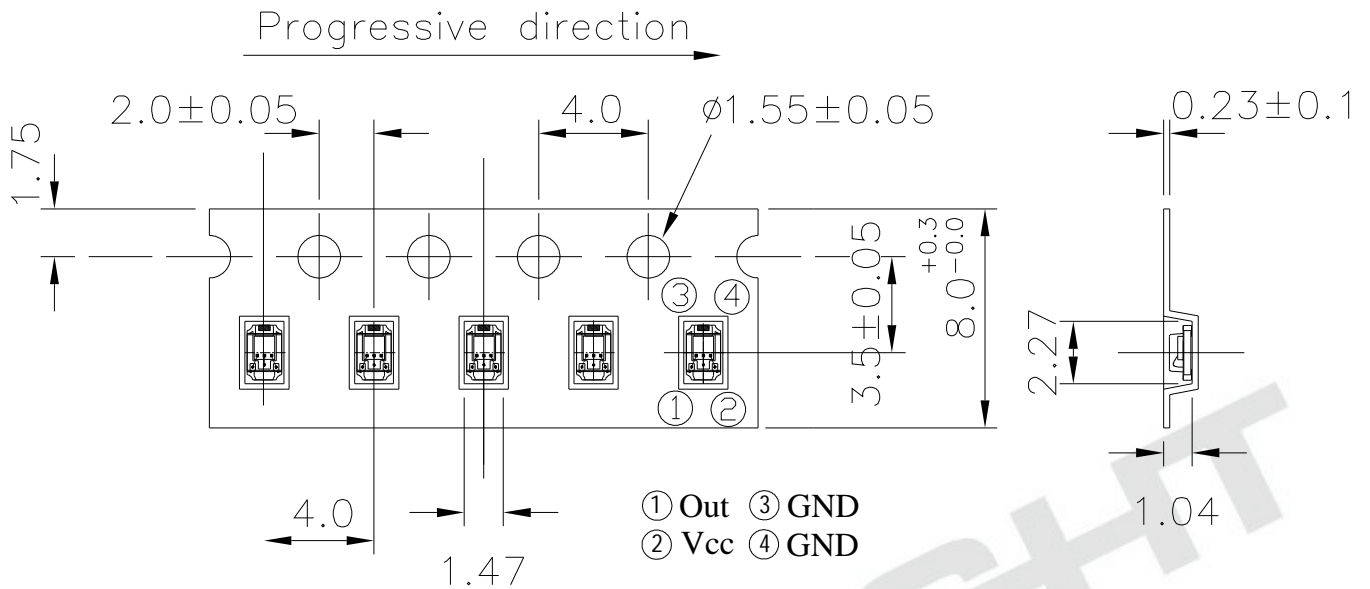

Unit: mm

Tolerance: $\pm 0.1\text{mm}$

Moisture Resistant Packaging

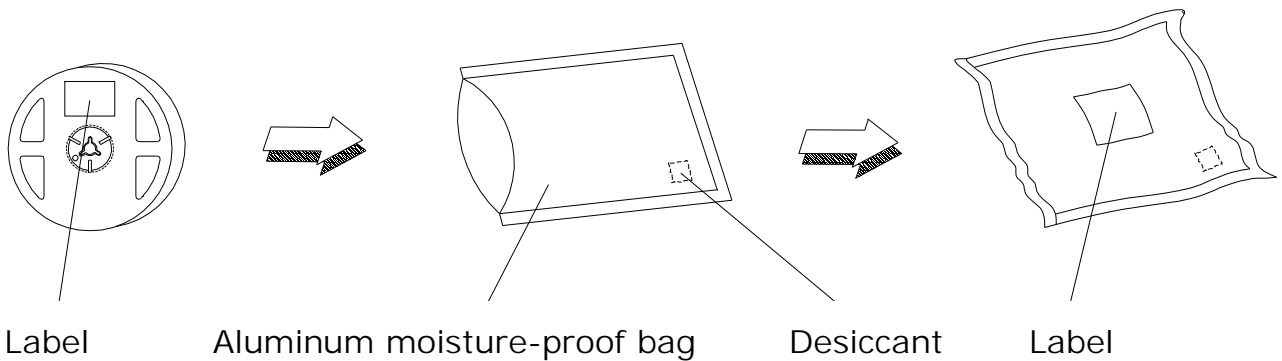

Note:

1. Above specification may be changed without notice. EVERLIGHT will reserve authority on material change for above specification.
2. When using this product, please observe the absolute maximum ratings and the instructions for using outlined in these specification sheets. EVERLIGHT assumes no responsibility for any damage resulting from use of the product which does not comply with the absolute maximum ratings and the instructions included in these specification sheets.
3. These specification sheets include materials protected under copyright of EVERLIGHT corporation. Please don't reproduce or cause anyone to reproduce them without EVERLIGHT's consent.

EVERLIGHT