



Compliance with RoHS Directive

### FEATURES

- Handles low level load 100  $\mu$ A at 3 VDC to 100 mA 30 VDC  
[Minimum switching capacity (reference value) 10  $\mu$ A at 1 VDC]
- Ultra-long stroke. For pin plunger type, it maintains an ultra-long stroke O.T. (Over Travel) with over 2.2 mm on the NO side and over 2.5 mm on the NC side.
- Since contact pressure does not depend on the operation stroke, the range of possible use over the entire stroke is greatly increased.
- Silent operation

### TYPICAL APPLICATIONS

- Household appliances  
(Cover detection of air conditioners and air purifiers for safety purpose. Cover destruction detection of crime prevention devices.)

### ORDERING INFORMATION

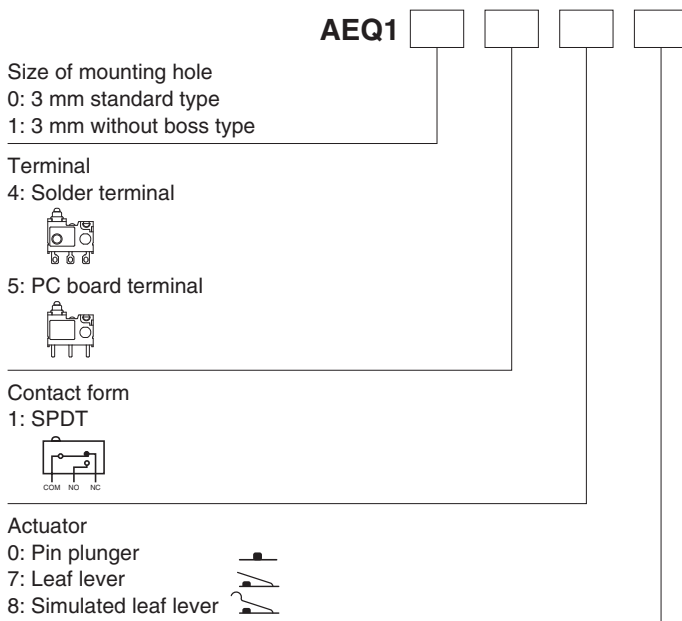

### PRODUCT TYPES

Terminal type (Mounting hole: 3mm standard type / 3mm without boss type)

| Actuator             | Operating force Max. | Mounting hole: 3mm standard type | Mounting hole: 3mm without boss type |
|----------------------|----------------------|----------------------------------|--------------------------------------|
|                      |                      | Solder terminal                  | PC board terminal                    |
| Pin plunger          | 1.2N                 | AEQ10410                         | AEQ11510                             |
| Leaf lever           | 1.7N                 | AEQ10417                         | AEQ11517                             |
| Simulated leaf lever | 1.5N                 | AEQ10418                         | AEQ11518                             |

# AEQ1

## RATING

### 1. Rating

100  $\mu$ A at 3 VDC to 100 mA 30 VDC.

[Min. switching capacity (Reference value\*) 10  $\mu$ A at 1 VDC]

\* This value is a rough indication of the lowest possible low level load at which switching is possible.

This value can change due to the switching frequency, environmental conditions, and desired reliability level, therefore it is recommended to check this with the actual load.

### 2. Operation environment and conditions

| Item                            | Specifications                              |
|---------------------------------|---------------------------------------------|
| Ambient and storage temperature | -25°C to +85°C (no freezing and condensing) |
| Allowable operating speed       | 30 to 500 mm/sec.                           |
| Max. operating cycle rate       | 120 cpm                                     |

Note 1: When switching at low and high speeds or under vibration, or in high-temperature, high-humidity environments, life and performance may be reduced significantly depending on the load capacity. Please consult us.

Note 2:

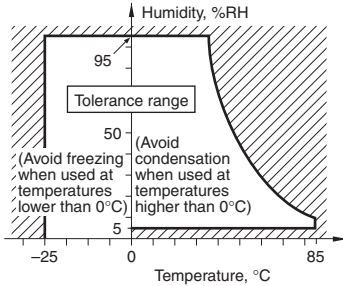

### 3. Electrical characteristics

|                                 |                                                                                                                                                                                          |
|---------------------------------|------------------------------------------------------------------------------------------------------------------------------------------------------------------------------------------|
| Breakdown voltage (Initial)     | Between non-continuous terminals: 600 Vrms, Between each terminal and other exposed metal parts: 1,500 Vrms, Between each terminal and ground: 1,500 Vrms (at detection current of 1 mA) |
| Insulation resistance (Initial) | Min. 100 M $\Omega$ (at 500 V DC insulation resistance meter, Locations measured same as breakdown voltage.)                                                                             |
| Contact resistance (Initial)    | Max. 1 $\Omega$ (by voltage drop 0.1 A, 6 to 8 V DC)                                                                                                                                     |

### 4. Characteristics

| Item                                                    | Specifications                                                                                                                                                            |
|---------------------------------------------------------|---------------------------------------------------------------------------------------------------------------------------------------------------------------------------|
| Electrical switching life                               | 3 V DC 0.1 mA (resistive load) Min. $2 \times 10^5$ Switching frequency: 20 times/min.<br>Conduction ratio: 1:1                                                           |
|                                                         | 30 V DC 100 mA (resistive load) Min. $10^5$ Pushbutton operation speed: 100 mm/s<br>Pushbutton switching position: free position (F.P.) to total travel position (T.T.P.) |
| Vibration resistance (malfunction vibration resistance) | Single amplitude: 0.75 mm<br>Amplitude of vibration: 10 to 55 Hz (4 minutes cycle)<br>Direction and time: 2 hours each in X, Y and Z directions                           |
| Shock resistance (malfunction shock resistance)         | Shock value: 294 m/s <sup>2</sup><br>Direction and time: 3 times each in X, Y and Z directions                                                                            |
| Vibration resistance endurance                          | Frequency of vibration: 33.3 Hz, Acceleration: 43.1 m/s <sup>2</sup><br>Direction and time: 8 hours each in X, Y and Z directions                                         |
| Terminal strength                                       | Min. 6 N (to each direction, applied power at 1 minute) *Terminal deformation possible.                                                                                   |
| Salt spray resistance                                   | Density of salt water: 5 %<br>Temperature: 35°C each 100 hours<br>At free position (F.P.) and total travel position (T.T.P.)                                              |
| Heat and cold resistance                                | -45 to -40°C 48 hours<br>85 to 90°C 48 hours                                                                                                                              |
| Humidity resistance                                     | 40°C 95% R.H. 96 hours                                                                                                                                                    |
| Protection grade                                        | IP40                                                                                                                                                                      |

Notes: As long as there are no particular designations, the following conditions apply to the test environment.

Ambient temperature: 5 to 35°C

Relative humidity: 25 to 85% R.H.

Air pressure: 86 to 106 kPa

5. Operating characteristics

| Item                                                | Standard value                          |            |                      |             |
|-----------------------------------------------------|-----------------------------------------|------------|----------------------|-------------|
|                                                     | Pin plunger                             | Leaf lever | Simulated leaf lever |             |
| Operating Force (max. O.F.) *Note 2                 | 1.2 N                                   | 1.7 N      | 1.5 N                |             |
| Total travel Force (max. T.F.) reference value      | (1.8 N)                                 | (3.1 N)    | (2.8 N)              |             |
| Free Position (max. F.P.)                           | From mounting boss and hole center line | 9.2 mm     | 11.5 mm              | 14.4 mm     |
| Operating Position on NC side [O.P. (N.C.)] *Note 3 | From mounting boss and hole center line | 8.7±0.3 mm | 9.8±0.5 mm           | 12.5±0.5 mm |
| Operating Position on NO side [O.P. (N.O.)] *Note 4 | From mounting boss and hole center line | 8.4±0.3 mm | 9.3±0.5 mm           | 12.0±0.5 mm |
| Release Position on NC side [R.P. (N.C.)] *Note 6   | From mounting boss and hole center line | 8.8±0.3 mm | 10.1±0.5 mm          | 12.9±0.5 mm |
| Release Position on NO side [R.P. (N.O.)] *Note 7   | From mounting boss and hole center line | 8.5±0.3 mm | 9.6±0.5 mm           | 12.4±0.5 mm |
| Over travel on NC side [min. O.T. (N.C.)]           |                                         | 2.5 mm     | 3.1 mm               | 3.3 mm      |
| Over travel on NO side [min. O.T. (N.O.)]           |                                         | 2.2 mm     | 2.6 mm               | 2.8 mm      |
| Total Travel Position (T.T.P.) reference value      | From mounting boss and hole center line | (5.9 mm)   | (6.2 mm)             | (8.7 mm)    |

- Notes: 1. The above indicates the characteristics when operating the pushbutton from the vertical direction.  
 2. Indicates operation load for NO contact to achieve ON status.  
 3. Indicates position for NC contact to achieve OFF status.  
 4. Indicates position for NO contact to achieve ON status.  
 5. Although there is some overlap in the range of the operating position (O.P.) on the NC and NO sides due to the tolerance, in actuality there is always an intermediate OFF range (the NC and NO sides will never ON at the same time.)  
 6. Indicates position for NC contact to achieve ON status.  
 7. Indicates position for NO contact to achieve OFF status.

OPERATION CONCEPT DIAGRAM

Contact form: terminal type

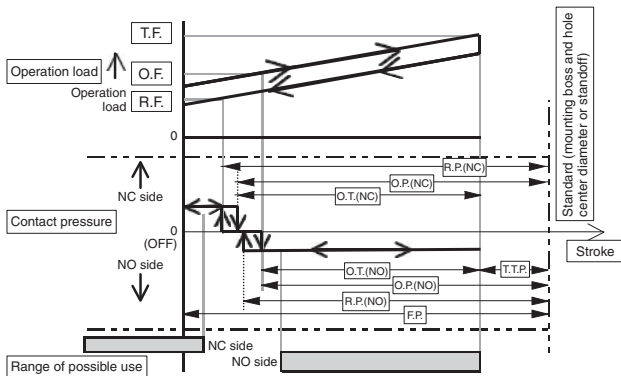

DATA

Applicable current range (reference)

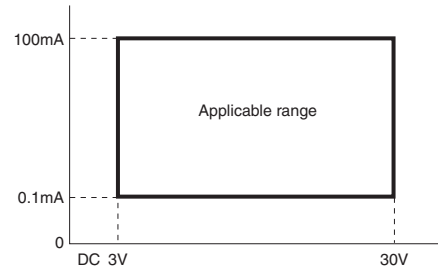

CONTACT ARRANGEMENT

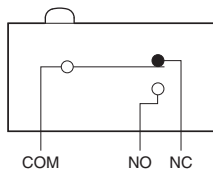

# AEQ1

## DIMENSIONS (Unit: mm)

The CAD data of the products with a **CAD Data** mark can be downloaded from: <http://panasonic-electric-works.net/ac>

### 1. Solder terminal; Mounting hole: 3mm, standard type

Pin plunger

**CAD Data**



External dimensions

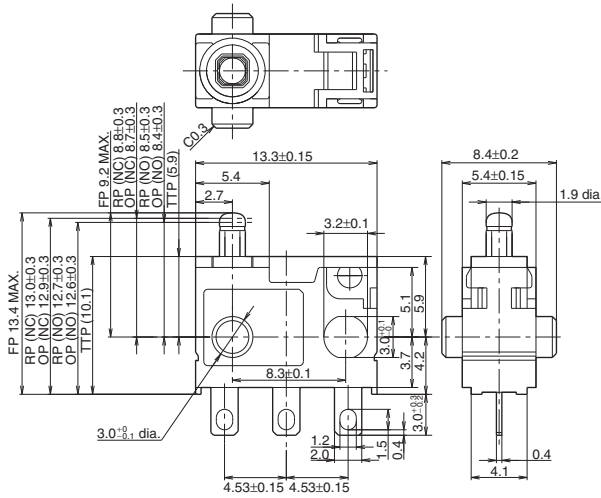

|                                                |                                         |             |
|------------------------------------------------|-----------------------------------------|-------------|
| Operating Force (max. O.F.)                    | 1.2 N                                   |             |
| Total travel Force (max. T.F.) reference value | (1.8 N)                                 |             |
| Free Position (F.P.)                           | From mounting boss and hole center line | 9.2 mm max. |
| Operating Position on NC side [O.P. (N.C.)]    | From mounting boss and hole center line | 8.7±0.3 mm  |
| Operating Position on NO side [O.P. (N.O.)]    | From mounting boss and hole center line | 8.4±0.3 mm  |
| Release Position on NC side [R.P. (N.C.)]      | From mounting boss and hole center line | 8.8±0.3 mm  |
| Release Position on NO side [R.P. (N.O.)]      | From mounting boss and hole center line | 8.5±0.3 mm  |
| Over travel on NC side [min. O.T. (N.C.)]      | 2.5 mm                                  |             |
| Over travel on NO side [min. O.T. (N.O.)]      | 2.2 mm                                  |             |

### 2. Leaf lever

**CAD Data**

External dimensions

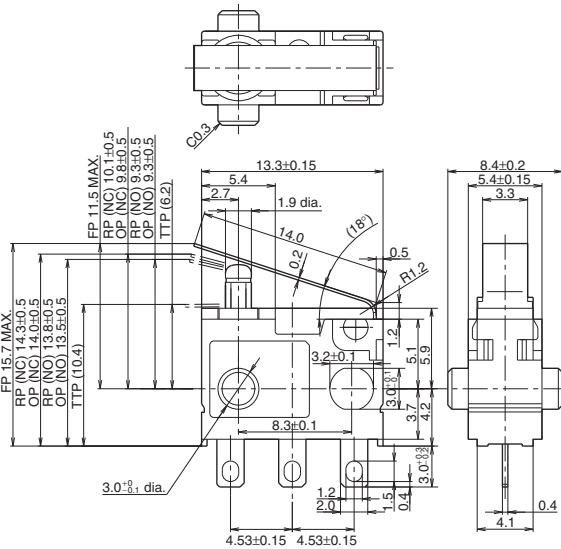

|                                                |                                         |              |
|------------------------------------------------|-----------------------------------------|--------------|
| Operating Force (max. O.F.)                    | 1.7 N                                   |              |
| Total travel Force (max. T.F.) reference value | (3.1 N)                                 |              |
| Free Position (F.P.)                           | From mounting boss and hole center line | 11.5 mm max. |
| Operating Position on NC side [O.P. (N.C.)]    | From mounting boss and hole center line | 9.8±0.5 mm   |
| Operating Position on NO side [O.P. (N.O.)]    | From mounting boss and hole center line | 9.3±0.5 mm   |
| Release Position on NC side [R.P. (N.C.)]      | From mounting boss and hole center line | 10.1±0.5 mm  |
| Release Position on NO side [R.P. (N.O.)]      | From mounting boss and hole center line | 9.6±0.5 mm   |
| Over travel on NC side [min. O.T. (N.C.)]      | 3.1 mm                                  |              |
| Over travel on NO side [min. O.T. (N.O.)]      | 2.6 mm                                  |              |

Note: When switching at high speed or under shock, lever endurance may drop. Therefore, please be sure to conduct an endurance evaluation under actual switching conditions.

### 3. Simulated leaf lever

**CAD Data**

External dimensions

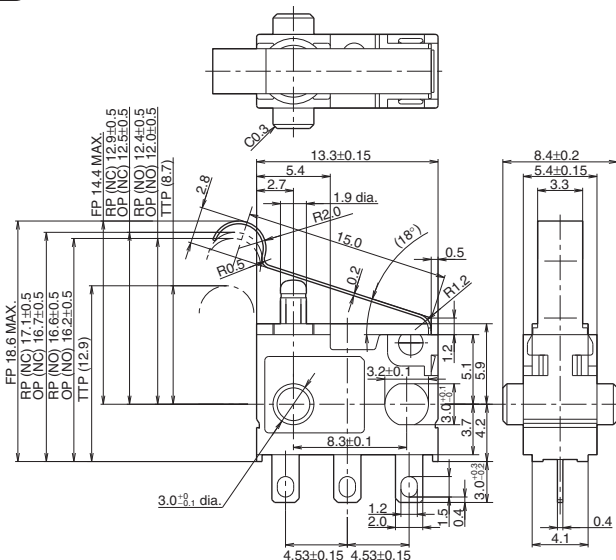

|                                                |                                         |              |
|------------------------------------------------|-----------------------------------------|--------------|
| Operating Force (max. O.F.)                    | 1.5 N                                   |              |
| Total travel Force (max. T.F.) reference value | (2.8 N)                                 |              |
| Free Position (F.P.)                           | From mounting boss and hole center line | 14.4 mm max. |
| Operating Position on NC side [O.P. (N.C.)]    | From mounting boss and hole center line | 12.5±0.5 mm  |
| Operating Position on NO side [O.P. (N.O.)]    | From mounting boss and hole center line | 12.0±0.5 mm  |
| Release Position on NC side [R.P. (N.C.)]      | From mounting boss and hole center line | 12.9±0.5 mm  |
| Release Position on NO side [R.P. (N.O.)]      | From mounting boss and hole center line | 12.4±0.5 mm  |
| Over travel on NC side [min. O.T. (N.C.)]      | 3.3 mm                                  |              |
| Over travel on NO side [min. O.T. (N.O.)]      | 2.8 mm                                  |              |

Note: When switching at high speed or under shock, lever endurance may drop. Therefore, please be sure to conduct an endurance evaluation under actual switching conditions.

4. PC board terminal; Mounting hole: 3 mm, without boss type

Pin plunger

CAD Data

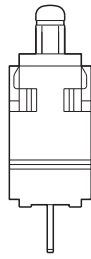
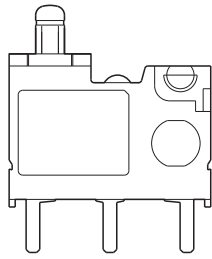

PC board terminal

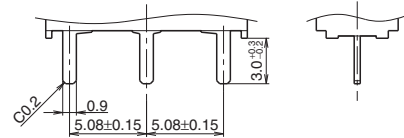

PC board pattern

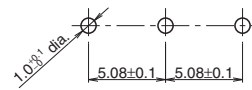

NOTES

■ Soldering conditions

Manual soldering: use soldering irons (max. 350°C, within 2 seconds) capable of temperature adjustment. This is to prevent deterioration due to soldering heat. Care should be taken not to apply force to the terminals during soldering. Terminal portion must not be moved within 1 minute after soldering.

■ Mounting

Please avoid use in which load would be applied to the sides [hatch part (both sides) shown below] of the switch in the direction indicated by the arrows. This could cause erroneous operation. Also, when using a metal installation board, please make allowance for burr direction designation and burr suppressing, etc., so that the burr side will not be on the switch installation side.

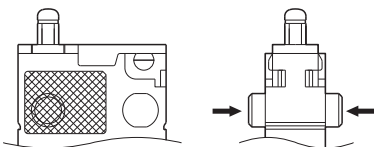

- 1) To secure the switch, please use an M3 small screw on a flat surface and tighten using a maximum torque of 0.29 N·m. It is recommended that spring washers be used with the screws and adhesive be applied to lock the screws to prevent loosening of the screws. Please make sure not to apply adhesive onto the moving parts.
- 2) Be sure to maintain adequate insulating clearance between each terminal and ground.
- 3) Although it is possible to directly operate the pin plunger type from the lateral direction, please consult us if doing so.
- 4) After mounting please make sure no tensile load will be applied to the switch terminals.

5) Range of possible use: Please set the operation position to within the ranges in the following table so that there is sufficient insulation distance and to maintain contact reliability.

| Actuator             | Plunger/lever free             |               |
|----------------------|--------------------------------|---------------|
|                      | From boss and hole center line | From standoff |
| Pin plunger          | >9.2 mm                        | >13.4 mm      |
| Leaf lever           | >10.7 mm                       | >14.9 mm      |
| Simulated leaf lever | >13.5 mm                       | >17.7 mm      |

| Actuator             | Plunger/Lever pushed           |                 |
|----------------------|--------------------------------|-----------------|
|                      | From boss and hole center line | From standoff   |
| Pin plunger          | 7.8 to 5.9 mm                  | 12.0 to 10.1 mm |
| Leaf lever           | 8.4 to 6.2 mm                  | 12.6 to 10.4 mm |
| Simulated leaf lever | 11.1 to 8.7 mm                 | 15.3 to 12.9 mm |

6) PC board terminal type should be used if the products are to be soldered on the PC board. (Solder terminal type is not for soldering on PC board.)

■ Cautions regarding the circuit

- 1) In order to prevent malfunction in set devices caused by bounce and chattering during the ON-OFF switch operation, please verify the validity of the circuit under actual operating conditions and temperature range.
- 2) When switching inductive loads (relays, solenoids, buzzers, etc.), an arc absorbing circuit is recommended to protect the contacts.

■ Please verify under actual conditions.

Please be sure to conduct quality verification under actual operating conditions in order to increase reliability during actual use.

■ Switch selection

Please make your selection so that there will be no problems even if the operating characteristics vary up to ±20% from the standard values.

■ Other

- 1) Keep away from environments where silicon based adhesives, oil or grease are present as faulty contacts may result from silicon oxide. Do not use in areas where flammable or explosive gases from gasoline and thinner, etc., may be present.
- 2) When using the lever type, please be careful not to apply unreasonable load from the reverse or lateral directions of operation.
- 3) Do not exceed the total travel position (TTP) and press the actuator. This could cause operation failure. Also, when switching at high speed or under shock even within the operation limit, the working life may decrease. Therefore, please be sure to verify the quality under actual conditions of use.
- 4) Please make considerations so that the switch does not become the stopper for the operating part. The switch could break.



North America

Europe

Asia Pacific

China

Japan

## Panasonic Electric Works

Please contact our Global Sales Companies in:

### Europe

|                           |                                                           |                                                                                                                                                                                                                            |
|---------------------------|-----------------------------------------------------------|----------------------------------------------------------------------------------------------------------------------------------------------------------------------------------------------------------------------------|
| ▶ <b>Headquarters</b>     | <b>Panasonic Electric Works Europe AG</b>                 | Rudolf-Diesel-Ring 2, 83607 Holzkirchen, Tel. +49 (0) 8024 648-0, Fax +49 (0) 8024 648-111, <a href="http://www.panasonic-electric-works.com">www.panasonic-electric-works.com</a>                                         |
| ▶ <b>Austria</b>          | <b>Panasonic Electric Works Austria GmbH</b>              | Rep. of PEWDE, Josef Madersperger Str. 2, 2362 Biedermansdorf, Tel. +43 (0) 2236-26846, Fax +43 (0) 2236-46133<br><a href="http://www.panasonic-electric-works.at">www.panasonic-electric-works.at</a>                     |
|                           | <b>PEW Electronic Materials Europe GmbH</b>               | Ennsshafenstraße 30, 4470 Enns, Tel. +43 (0) 7223 883, Fax +43 (0) 7223 88333, <a href="http://www.panasonic-electronic-materials.com">www.panasonic-electronic-materials.com</a>                                          |
| ▶ <b>Benelux</b>          | <b>Panasonic Electric Works Sales Western Europe B.V.</b> | De Rijn 4, (Postbus 211), 5684 PJ Best, (5680 AE Best), Netherlands, Tel. +31 (0) 499 372727, Fax +31 (0) 499 372185,<br><a href="http://www.panasonic-electric-works.nl">www.panasonic-electric-works.nl</a>              |
| ▶ <b>Czech Republic</b>   | <b>Panasonic Electric Works Czech s.r.o.</b>              | Průmyslová 1, 34815 Planá, Tel. (+420)-374 799 990, Fax (+420)-374 799 999, <a href="http://www.panasonic-electric-works.cz">www.panasonic-electric-works.cz</a>                                                           |
| ▶ <b>France</b>           | <b>Panasonic Electric Works Sales Western Europe B.V.</b> | Succursale française, 10, rue des petits ruisseaux, 91370 Verrières Le Buisson, Tél. +33 (0) 1 6013 5757, Fax +33 (0) 1 6013 5758,<br><a href="http://www.panasonic-electric-works.fr">www.panasonic-electric-works.fr</a> |
| ▶ <b>Germany</b>          | <b>Panasonic Electric Works Deutschland GmbH</b>          | Rudolf-Diesel-Ring 2, 83607 Holzkirchen, Tel. +49 (0) 8024 648-0, Fax +49 (0) 8024 648-555, <a href="http://www.panasonic-electric-works.de">www.panasonic-electric-works.de</a>                                           |
| ▶ <b>Hungary</b>          | <b>Panasonic Electric Works Europe AG</b>                 | Erdőalja út 91/a, 1037 Budapest, Tel. +36 (0) 20 9715688, <a href="http://www.panasonic-electric-works.hu">www.panasonic-electric-works.hu</a>                                                                             |
| ▶ <b>Ireland</b>          | <b>Panasonic Electric Works UK Ltd.</b>                   | Dublin, Tel. +353 (0) 14600969, Fax +353 (0) 14601131, <a href="http://www.panasonic-electric-works.co.uk">www.panasonic-electric-works.co.uk</a>                                                                          |
| ▶ <b>Italy</b>            | <b>Panasonic Electric Works Italia srl</b>                | Via del Commercio 3-5 (Z.I. Ferlina), 37012 Bussolengo (VR), Tel. +39 (0) 456752711, Fax +39 (0) 456700444,<br><a href="http://www.panasonic-electric-works.it">www.panasonic-electric-works.it</a>                        |
| ▶ <b>Nordic Countries</b> | <b>Panasonic Electric Works Nordic AB</b>                 | Sjöängsvägen 10, 19272 Sollentuna, Sweden, Tel. +46 859476680, Fax +46 859476690, <a href="http://www.panasonic-electric-works.se">www.panasonic-electric-works.se</a>                                                     |
| ▶ <b>Poland</b>           | <b>Panasonic Electric Works Polska sp. z o.o</b>          | Jungmansgatan 12, 21119 Malmö, Tel. +46 40 697 7000, Fax +46 40 697 7099, <a href="http://www.panasonic-fire-security.com">www.panasonic-fire-security.com</a>                                                             |
| ▶ <b>Portugal</b>         | <b>Panasonic Electric Works España S.A.</b>               | Al. Krakowska 4/6, 02-284 Warszawa, Tel. +48 (0) 22 338-11-33, Fax +48 (0) 22 338-12-00, <a href="http://www.panasonic-electric-works.pl">www.panasonic-electric-works.pl</a>                                              |
| ▶ <b>Spain</b>            | <b>Panasonic Electric Works España S.A.</b>               | Portuguese Branch Office, Avda Adelino Amaro da Costa 728 R/C J, 2750-277 Cascais, Tel. +351 214812520, Fax +351 214812529                                                                                                 |
| ▶ <b>Switzerland</b>      | <b>Panasonic Electric Works Schweiz AG</b>                | Barajas Park, San Severo 20, 28042 Madrid, Tel. +34 913293875, Fax +34 913292976, <a href="http://www.panasonic-electric-works.es">www.panasonic-electric-works.es</a>                                                     |
| ▶ <b>United Kingdom</b>   | <b>Panasonic Electric Works UK Ltd.</b>                   | Grundstrasse 8, 6343 Rotkreuz, Tel. +41 (0) 41 7997050, Fax +41 (0) 41 7997055, <a href="http://www.panasonic-electric-works.ch">www.panasonic-electric-works.ch</a>                                                       |
|                           |                                                           | Sunrise Parkway, Linford Wood, Milton Keynes, MK14 6 LF, Tel. +44 (0) 1908 231555, Fax +44 (0) 1908 231599,<br><a href="http://www.panasonic-electric-works.co.uk">www.panasonic-electric-works.co.uk</a>                  |

### North & South America

|              |                                   |                                                                                                                                                             |
|--------------|-----------------------------------|-------------------------------------------------------------------------------------------------------------------------------------------------------------|
| ▶ <b>USA</b> | <b>PEW Corporation of America</b> | 629 Central Avenue, New Providence, N.J. 07974, Tel. 1-908-464-3550, Fax 1-908-464-8513, <a href="http://www.pewa.panasonic.com">www.pewa.panasonic.com</a> |
|--------------|-----------------------------------|-------------------------------------------------------------------------------------------------------------------------------------------------------------|

### Asia Pacific/China/Japan

|                    |                                                        |                                                                                                                                                                                |
|--------------------|--------------------------------------------------------|--------------------------------------------------------------------------------------------------------------------------------------------------------------------------------|
| ▶ <b>China</b>     | <b>Panasonic Electric Works (China) Co., Ltd.</b>      | Level 2, Tower W3, The Towers Oriental Plaza, No. 2, East Chang An Ave., Dong Cheng District, Beijing 100738, Tel. (010) 5925-5988, Fax (010) 5925-5973                        |
| ▶ <b>Hong Kong</b> | <b>Panasonic Electric Works (Hong Kong) Co., Ltd.</b>  | RM1205-9, 12/F, Tower 2, The Gateway, 25 Canton Road, Tsimshatsui, Kowloon, Hong Kong, Tel. (0852) 2956-3118, Fax (0852) 2956-0398                                             |
| ▶ <b>Japan</b>     | <b>Panasonic Electric Works Co., Ltd.</b>              | 1048 Kadoma, Kadoma-shi, Osaka 571-8686, Japan, Tel. (06) 6908-1050, Fax (06) 6908-5781, <a href="http://panasonic-electric-works.net">http://panasonic-electric-works.net</a> |
| ▶ <b>Singapore</b> | <b>Panasonic Electric Works Asia Pacific Pte. Ltd.</b> | 101 Thomson Road, #25-03/05, United Square, Singapore 307591, Tel. (06255) 5473, Fax (06253) 5689                                                                              |