



■ Features :

- Low power consumption
- High efficiency and low cost
- Good control and free combinations on the colors of LED lamps
- Good lock and easy to assembly
- Stackable and easy to assembly
- Stackable vertically and easy to assembly
- Versatile mounting on P.C board or panel
- Stackable horizontally and easy to assembly
- Pb free
- The product itself will remain within RoHS compliant version

■ Descriptions :

- ARRAY=Plastic Holder+Combinations of Lamps
- The array will easily mount the applicable lamps on any panel up to

■ Applications :

- 1.Used as indicators of indicating the Degree, Functions, Positions etc, in electronic instruments.

PART NO.	Chip		Lens Color
	Material	Emitted Color	
316SDRSYGW/S530-E2	AlGaInP	Super Deep-Red	White Diffused
	AlGaInP	Super Yellow Green	

Technical Data Sheet

3mm 1pcs Circuit Board Indicator

A96B/SDRSYGW/S530-E2

Package Dimensions

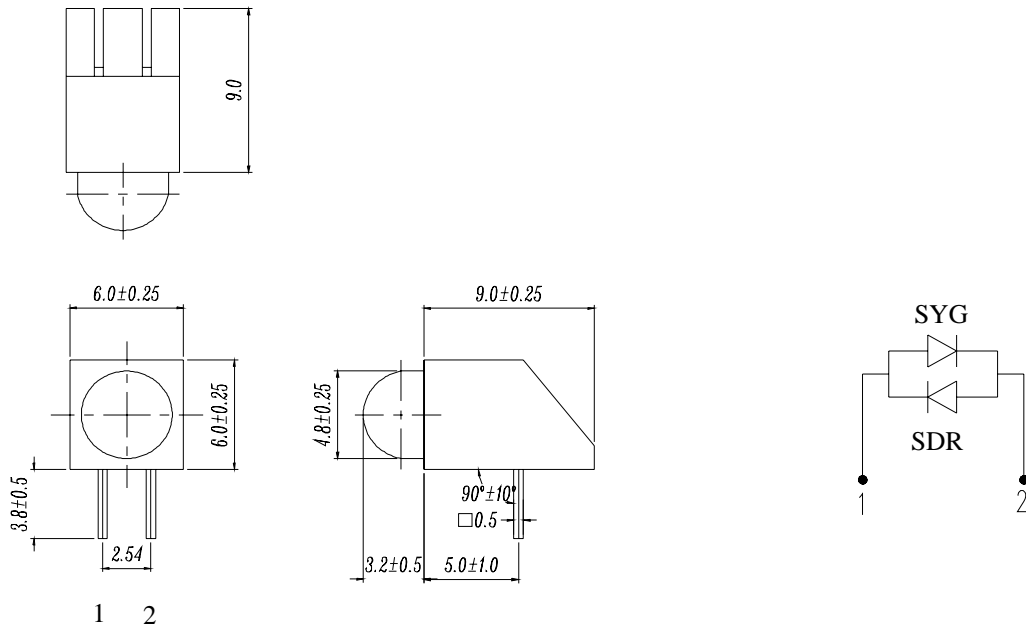

- Notes: 1.All dimensions are in millimeters, tolerance is 0.25mm except being specified
2.Lead spacing is measured where the lead emerge from the package

Absolute Maximum Ratings at Ta = 25°C

Parameter	Symbol		Rating	Unit
Forward Current	IF	SDR/S530	25	mA
		SYG/S530	25	
Operating Temperature	Topr		-40 to +85	°C
Storage Temperature	Tstg		-40 to +100	°C
Soldering Temperature	Tsol		260 ± 5	°C
Electrostatic Discharge	ESD	SDR/S530	2000	V
		SYG/S530	2000	
Power Dissipation	Pd	SDR/S530	60	mW
		SYG/S530	60	
Reverse Voltage	VR		5	V

Note: *1:Soldering time ≤ 5 seconds.



Technical Data Sheet

3mm 1pcs Circuit Board Indicator

A96B/SDRSYGW/S530-E2

Electro-Optical Characteristics (Ta=25°C)

Parameter	Symbol	Condition	Min	Typ	Max	Unit
Luminous Intensity	SDR/S530	$I_F = 20 \text{ mA}$	32	50	/	mcd
	SYG/S530		20	40	/	
Peak Wavelength	SDR/S530	$I_F = 20 \text{ mA}$	/	650	/	nm
	SYG/S530		/	575	/	
Dominant Wavelength	SDR/S530	$I_F = 20 \text{ mA}$	/	639	/	nm
	SYG/S530		/	573	/	
Viewing Angle	$2\theta_{1/2}$	$I_F = 20 \text{ mA}$	/	80	/	deg
Spectrum Radiation Bandwidth	SDR/S530	$I_F = 20 \text{ mA}$	/	20	/	nm
	SYG/S530		/	20	/	
Forward Voltage	SDR/S530	$I_F = 20 \text{ mA}$	/	2.0	2.4	V
	SYG/S530		/	2.0	2.4	
Reverse Current	SDR/S530	$V_R = 5 \text{ V}$	/	/	10	μA
	SYG/S530		/	/	10	

Typical Electro-Optical Characteristic Curves:

(SDR)

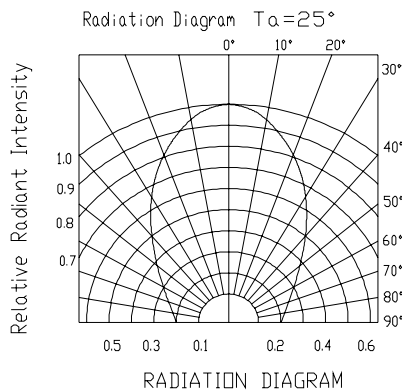
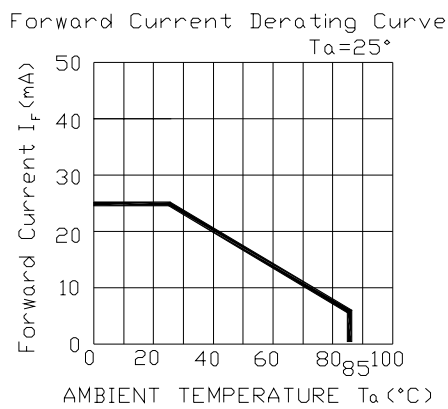
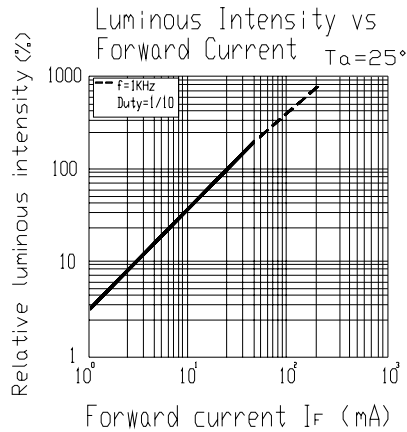
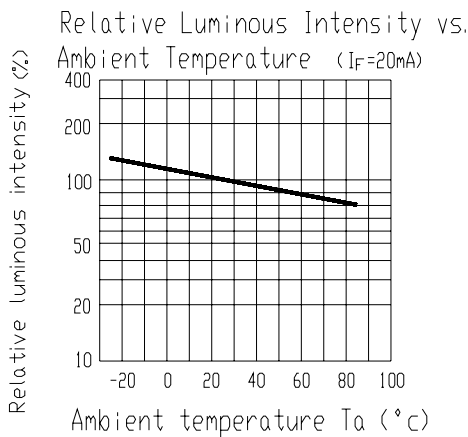
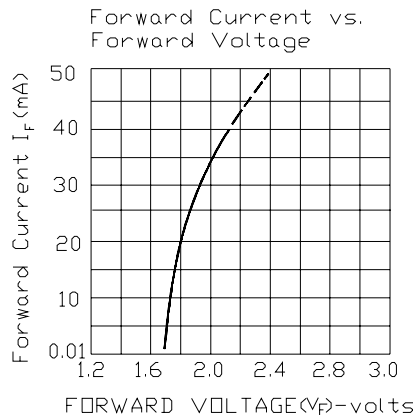
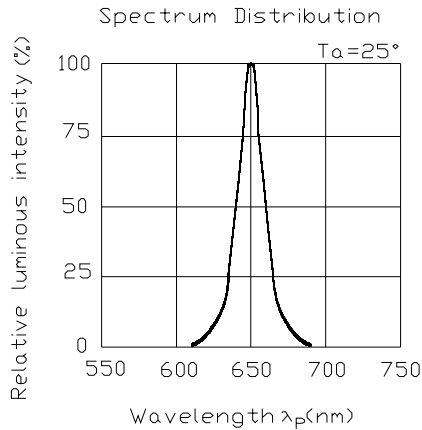

A96B/SDRSYGW/S530-E2

■ Typical Electro-Optical Characteristic Curves:

(SYG)

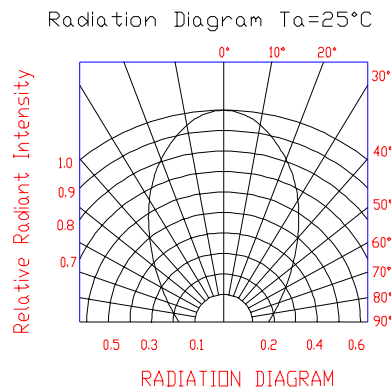
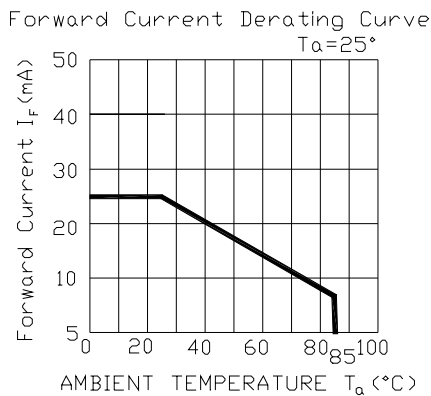
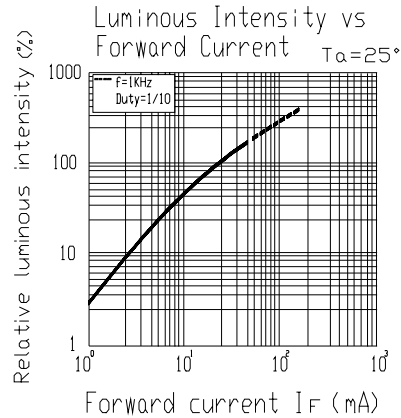
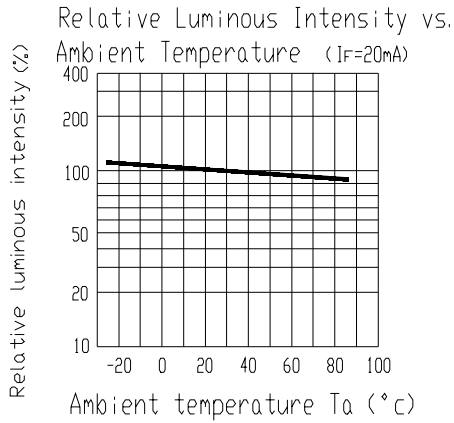
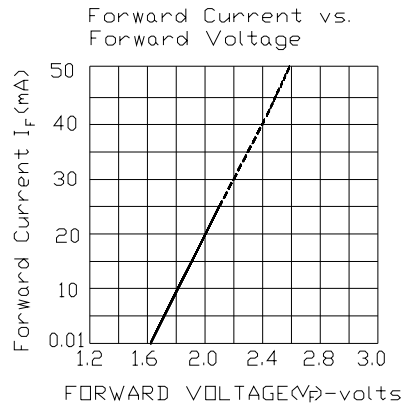
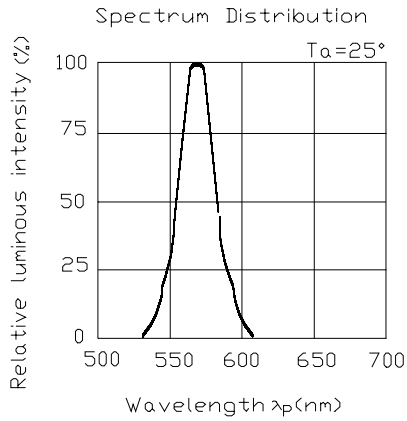

Technical Data Sheet

3mm 1pcs Circuit Board Indicator

A96B/SDRSYGW/S530-E2

■ Reliability test items and conditions:

The reliability of products shall be satisfied with items listed below.

Confidence level : 97%

LTPD : 3%

NO	Item	Test Conditions	Test Hours/Cycle	Sample Size	Failure Judgment Criteria	Ac/Re
1	Solder Heat	TEMP : 260°C ± 5 °C	10 SEC	76 PCS	$I_v \leq I_{vt} * 0.5$ or $V_f \geq U$ or $V_f \leq L$	0/1
2	Temperature Cycle	H : +100°C 15min \int 5 min L : -40°C 15min	300 CYCLES	76 PCS		0/1
3	Thermal Shock	H : +100°C 5min \int 10 sec L : -10°C 5min	300 CYCLES	76 PCS		0/1
4	High Temperature Storage	TEMP : 100°C	1000 HRS	76 PCS		0/1
5	Low Temperature Storage	TEMP : -40°C	1000 HRS	76 PCS		0/1
6	DC Operating Life	TEMP : 25°C I _F = 20mA	1000 HRS	76 PCS		0/1
7	High Temperature / High Humidity	85°C / 85% RH	1000 HRS	76 PCS		0/1

Note : I_{vt} : To test I_v value of the chip before the reliability test

I_v : The test value of the chip that has completed the reliability test

U : Upper Specification Limit

L : Lower Specification Limit



LIGHTING FOREVER

Technical Data Sheet

3mm 1pcs Circuit Board Indicator

A96B/SDRSYGW/S530-E2

Packing Quantity Specification

- 1.500PCS/1plate , 4 plates/1Box
- 2. 10Boxes/1Carton

Label Form Specification

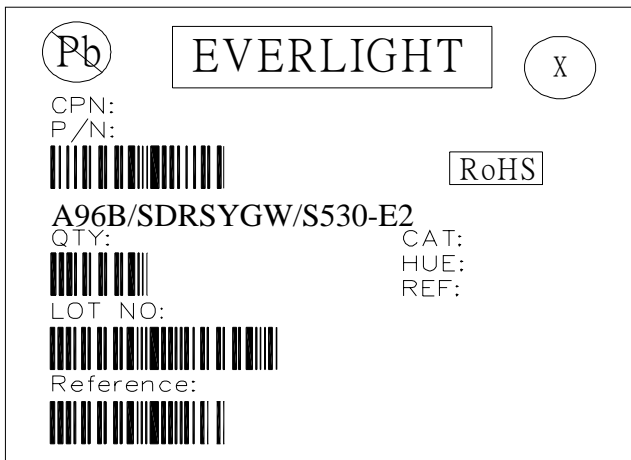

- CPN: Customer' s Production Number
- P/N : Production Number
- QTY: Packing Quantity
- CAT: Ranks
- HUE: Dominant Wavelength
- REF: Reference
- LOT No: Lot Number
- MADE IN TAIWAN: Production Place

Notes

- Above specification may be changed without notice. EVERLIGHT will reserve authority on material change for above specification.
- When using this product, please observe the absolute maximum ratings and the instructions for using outlined in these specification sheets. EVERLIGHT assumes no responsibility for any damage resulting from use of the product which does not comply with the absolute maximum ratings and the instructions included in these specification sheets.
- These specification sheets include materials protected under copyright of EVERLIGHT corporation. Please don' t reproduce or cause anyone to reproduce them without EVERLIGHT' s consent.

<i>EVERLIGHT ELECTRONICS CO., LTD.</i>	<i>Tel: 886-2-2267-2000, 2267-9936</i>
<i>Office: No 25, Lane 76, Sec 3, Chung Yang Rd,</i>	<i>Fax: 886-2267-6244, 2267-6189, 2267-6306</i>
<i>Tucheng, Taipei 236, Taiwan, R.O.C</i>	<i>http://www.everlight.com</i>