

Permanent Light 209 / Accessories
Base w. integrated tube BK



Part No.: 975.209.01

MECHANICAL DATA

Height	110 mm
Diameter	70 mm
Materials	PA-GF
Housing colour	Black
Weight with packaging	62 g
Product weight	62 g

DRAWING

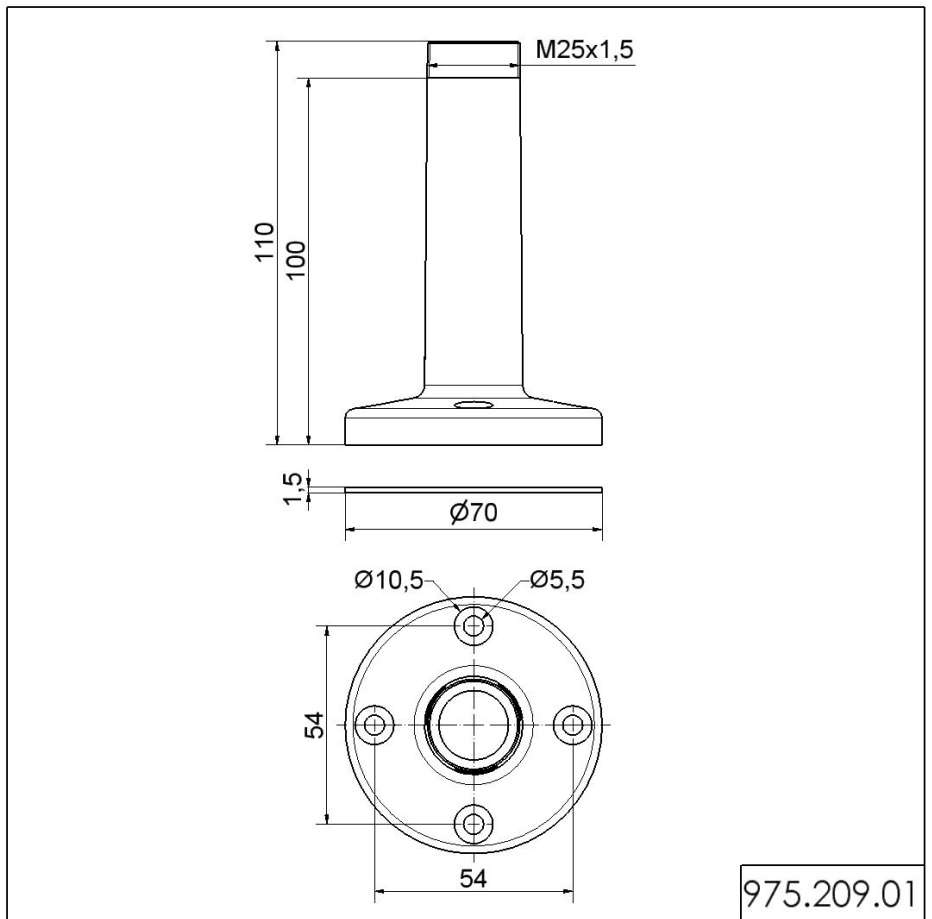

! For additional installation and mounting information, refer to the appropriate user guide at www.werma.com. This printed copy is for information only and is subject to alteration.