



UZ210

Universal signal converter: Analog (V/mA) - Incremental / SSI / RS232 / RS485

Product Features:

- Analog input for voltage, current or potentiometer operation
- Operation as frequency converter/-generator, positional / angular encoder or data logging possible
- Programmable curves with optionally repeating curve cycles
- Frequency output (HTL or TTL level, max. 1 MHz) proportional to the input signal
- Incremental output and SSI interface, for digital expression of linear or angular positions
- Incremental direction signal A, B under control of input signal and parameter settings
- Additional control functions similar to a motorized potentiometer
- USB programming port and serial interface (RS232 / RS485)
- Programmable marker resp. index pulse output (Z, /Z)
- Power supply 12 to 30 VDC

Version:	Description:
UZ21001a_af_hk/Feb12	First edition
UZ21002a_af_hk/Jul12	Extensions for communication via USB port
Uz210_02b_af_sn/Dec14	Extensions for inhibit-function
Uz210_02c_oi_/Dez-15/ag	Safety Instructions, Legal Notices and design added resp. updated. Connection diagram: mistake eliminated (X4/1 = GND instead of AGND). Analog in drawings: mistake eliminated (AGND = X4/6 instead of X4/1). Addition (Techn. Specifications): "SSI - only single transmission supported". Hint supplemented: Only RS232 or RS485 (not both at the same time).

Legal notices:
All contents included in this manual are protected by the terms of use and copyrights of motrona GmbH. Any reproduction, modification, usage or publication in other electronic and printed media as well as in the internet requires prior written authorization by motrona GmbH.

Table of Contents

1. Safety Instructions and Responsibility	4
1.1 General Safety Instructions	4
1.2 Use according to the intended purpose.....	4
1.3 Installation	5
1.4 Cleaning, Maintenance and Service Notes.....	5
2. Introduction	6
2.1. Operation as Signal Converter.....	7
2.2. Operation as Frequency or Position Generator (Motorized Potentiometer Mode)	7
3. Typical Examples of Application	8
3.1. UZ 210 as Analogue-to-Frequency Converter or Generator	8
3.2. UZ 210 as Positional or Angular Encoder with Analogue Input.....	9
3.3. UZ 210 for PC Applications (Data Logging)	9
4. Connections and Control Elements	10
4.1. Power Supply	10
4.2. Control Inputs Control1 - Control4.....	11
4.3. The SSI Interface	11
4.4. Analogue Inputs.....	12
4.5. Incremental Outputs	12
4.6. The Serial Interface	13
4.7. The USB Communication Port.....	14
4.8. The Front DIL Switch and the Front LEDs.....	14
5. Parameter Settings	15
5.1. General Settings	16
5.2. Analogue Settings (Analogue Input).....	17
5.3. SSI Setting (SSI Data Transmission)	17
5.4. Encoder Setting (Incremental Output)	18
5.5. Command Setting (Control Inputs).....	18
5.6. Serial Setting (RS232/RS485 Interface).....	19
5.7. Linearization Setting	20
5.8. Hints for Use of the Linearization Function.....	20
6. Hints for Serial Communication	21
6.1. Automatic and Cyclic Data Transmission.....	21
6.2. Communication Protocol.....	22
7. Hints for Operation of the USB Port	24
8. Technical Specifications	26
9. Dimensions.....	27

1. Safety Instructions and Responsibility

1.1 General Safety Instructions

This operation manual is a significant component of the unit and includes important rules and hints about the installation, function and usage. Non-observance can result in damage and/or impairment of the functions to the unit or the machine or even in injury to persons using the equipment!

Please read the following instructions carefully before operating the device and observe all safety and warning instructions! Keep the manual for later use.

A pertinent qualification of the respective staff is a fundamental requirement in order to use these manual. The unit must be installed, connected and put into operation by a qualified electrician.

Liability exclusion: The manufacturer is not liable for personal injury and/or damage to property and for consequential damage, due to incorrect handling, installation and operation. Further claims, due to errors in the operation manual as well as misinterpretations are excluded from liability.

In addition the manufacturer reserve the right to modify the hardware, software or operation manual at any time and without prior notice. Therefore, there might be minor differences between the unit and the descriptions in operation manual.

The raiser respectively positioner is exclusively responsible for the safety of the system and equipment where the unit will be integrated.

During installation or maintenance all general and also all country- and application-specific safety rules and standards must be observed.

If the device is used in processes, where a failure or faulty operation could damage the system or injure persons, appropriate precautions to avoid such consequences must be taken.

1.2 Use according to the intended purpose

The unit is intended exclusively for use in industrial machines, constructions and systems. Non-conforming usage does not correspond to the provisions and lies within the sole responsibility of the user. The manufacturer is not liable for damages which has arisen through unsuitable and improper use.

Please note that device may only be installed in proper form and used in a technically perfect condition - in accordance to the Technical Specifications (see chapter [8](#)). The device is not suitable for operation in explosion-proof areas or areas which are excluded by the EN 61010-1 standard.

1.3 Installation

The device is only allowed to be installed and operated within the permissible temperature range. Please ensure an adequate ventilation and avoid all direct contact between the device and hot or aggressive gases and liquids.

Before installation or maintenance, the unit must be disconnected from all voltage-sources. Further it must be ensured that no danger can arise by touching the disconnected voltage-sources.

Devices which are supplied by AC-voltages, must be connected exclusively by switches, respectively circuit-breakers with the low voltage network. The switch or circuit-breaker must be placed as near as possible to the device and further indicated as separator.

Incoming as well as outgoing wires and wires for extra low voltages (ELV) must be separated from dangerous electrical cables (SELV circuits) by using a double resp. increased isolation.

All selected wires and isolations must be conform to the provided voltage- and temperature-ranges. Further all country- and application-specific standards, which are relevant for structure, form and quality of the wires, must be ensured. Indications about the permissible wire cross-sections for wiring are described in the Technical Specifications (see chapter [8](#)).

Before first start-up it must be ensured that all connections and wires are firmly seated and secured in the screw terminals. All (inclusively unused) terminals must be fastened by turning the relevant screws clockwise up to the stop.

Overvoltages at the connections must be limited to values in accordance to the overvoltage category II.

For placement, wiring, environmental conditions as well as shielding and earthing/grounding of the supply lines the general standards of industrial automation industry and the specific shielding instructions of the manufacturer are valid. Please find all respective hints and rules on www.motrona.com/download.html --> "[General EMC Rules for Wiring, Screening and Earthing]".

1.4 Cleaning, Maintenance and Service Notes

To clean the front of the unit please use only a slightly damp (not wet!), soft cloth. For the rear no cleaning is necessary. For an unscheduled, individual cleaning of the rear the maintenance staff or assembler is self-responsible.

During normal operation no maintenance is necessary. In case of unexpected problems, failures or malfunctions the device must be shipped for back to the manufacturer for checking, adjustment and reparation (if necessary). Unauthorized opening and repairing can have negative effects or failures to the protection-measures of the unit.

2. Introduction

UZ 210 is a versatile and competitive signal converter and frequency generator for use with industrial applications in drive and automation technology.

Functional overview:

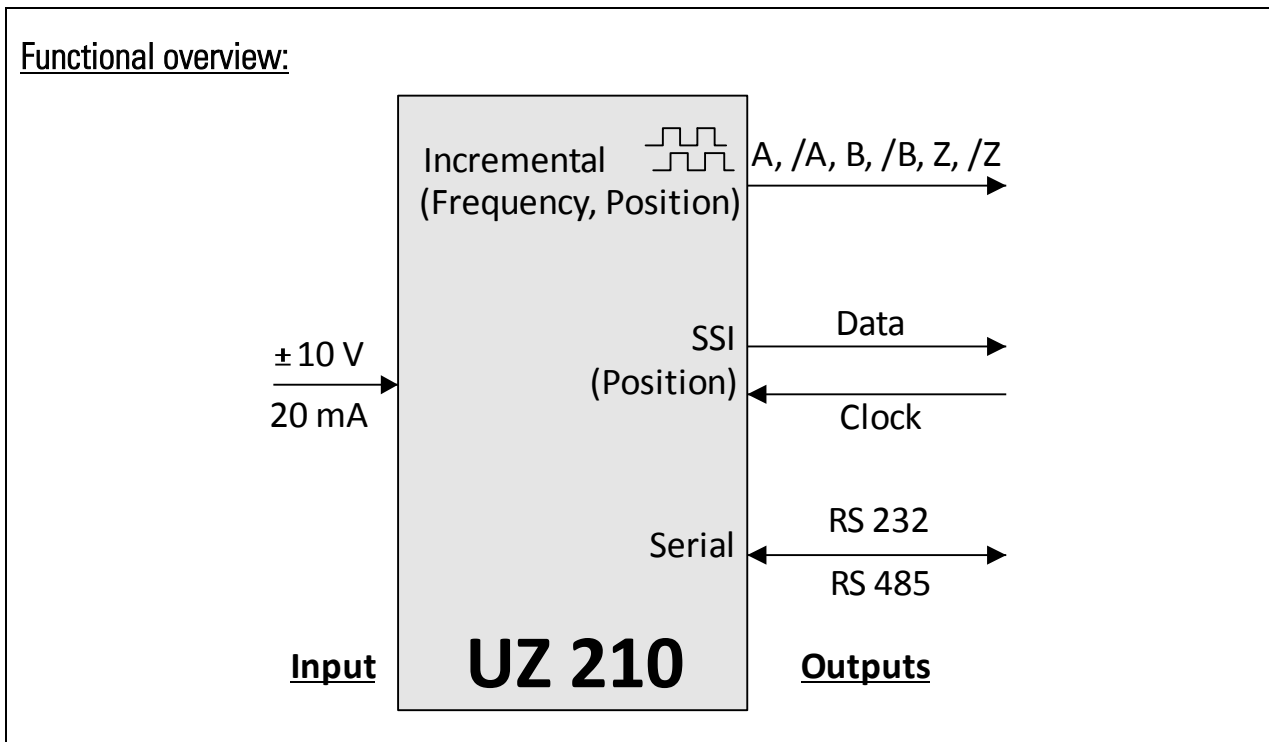

The unit accepts analogue input signals (0 - $\pm 10\text{ V}$, 0 - 20 mA or 4 - 20 mA) for conversion to digital output signals.

Due to an inbuilt reference voltage source it is also easy to connect potentiometers or similar analogue transducer systems to the input of the unit.



The USB communication port is not available with the previous version UZ210.01.

2.1. Operation as Signal Converter

The conversion output generated from the analogue input is available with following formats:

- **Frequency**
The unit converts the analogue input into a proportional output frequency with a free programmable range between 0,01 Hz and 1 MHz. A full set of impulse channels A, /A, B, /B, Z, /Z is available and the direction information (A, B, 90°) automatically considers the actual state and course of the analogue input with regard to the related parameter settings. An external voltage connected to terminal [Com+] defines the output voltage level (range 5 - 30 V). Where no remote voltage has been applied (Com+ unconnected), the unit automatically provides a 4 volts output (TTL compatible).
- **Linear or angular position with incremental representation**
The unit converts the analogue input into a positional or angular information similar to an incremental encoder. This means that e.g. the rotation angle of an analogue potentiometer shaft converts to real incremental encoder information. The unit provides a full set of output channels A, /A, B, /B, Z /Z, and the directional information (A, B, 90°) fully follows the mechanical motion of the potentiometer. The impulse level on the incremental output is determined by the remote voltage applied to terminal [Com+] (range 5 - 30 V). When no external voltage is applied (i.e. terminal Com+ unconnected) the unit automatically generates a 4 volts signal swing (TTL compatible).
- **Linear or angular position with absolute SSI output**
The unit converts the analogue input into a positional or angular information similar to an absolute encoder with SSI interface. This means that e.g. the rotation angle of an analogue potentiometer shaft converts to real SSI encoder information. Similar to a real SSI encoder the UZ 210 converter always acts as a "Slave" responding to the clock signal of a remote SSI master unit. All SSI signal levels are in line with the common SSI standard (TTL-differential or RS422 respectively).
- **Serial and USB**
At any time and with all modes of operation the conversion result of the unit is accessible by PC or PLC, via the serial interface or by the converter's USB port

2.2. Operation as Frequency or Position Generator (Motorized Potentiometer Mode)

With this mode of operation the unit functions similar to a motorized potentiometer or to a digital positioning axis.

In frequency mode the unit generates a scalable frequency output where the frequency can be adjusted via remote commands „UP“ (increase) and „DOWN“ (decrease). In positioning mode the unit generates quadrature counting impulses in forward or reverse direction, under control of the „UP“ and „DOWN“ commands (virtual positioning axis).

Moreover the unit provides a „Repeat“-Function for cyclic execution of frequency or position curves within programmable limits.

3. Typical Examples of Application

3.1. UZ 210 as Analogue-to-Frequency Converter or Generator

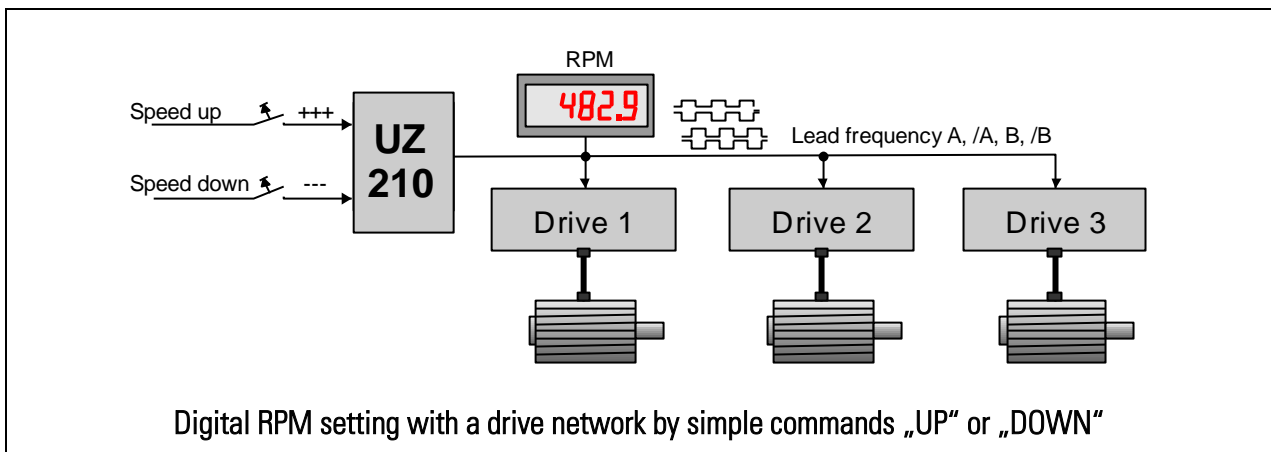
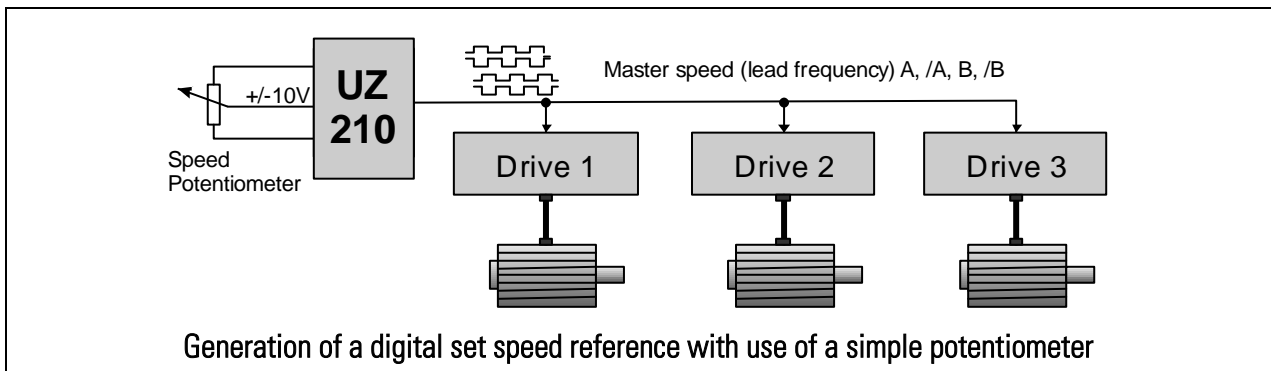
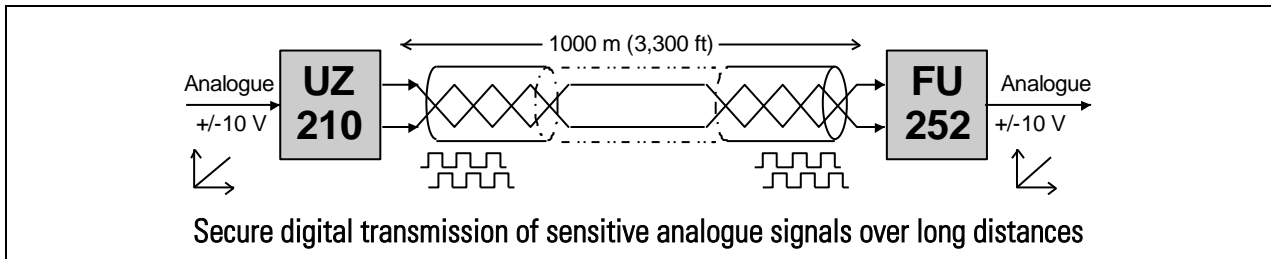

3.2. UZ 210 as Positional or Angular Encoder with Analogue Input

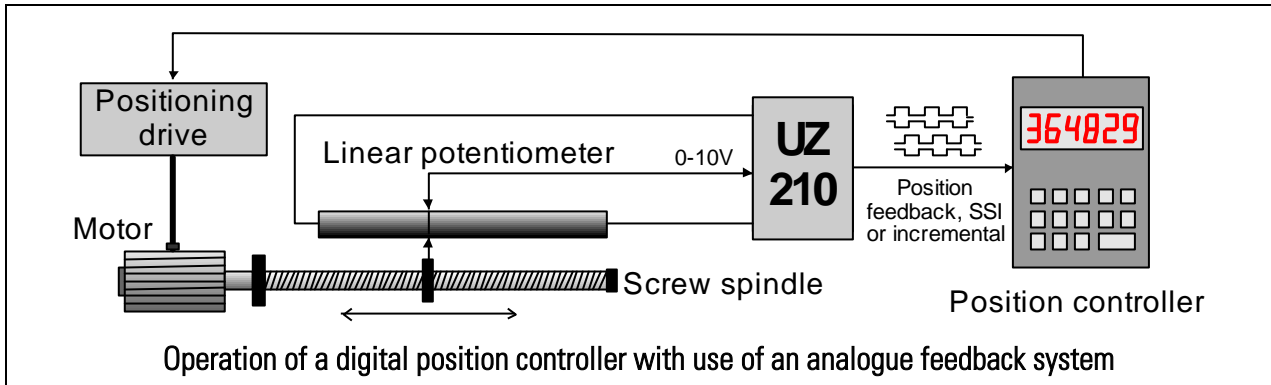

3.3. UZ 210 for PC Applications (Data Logging)

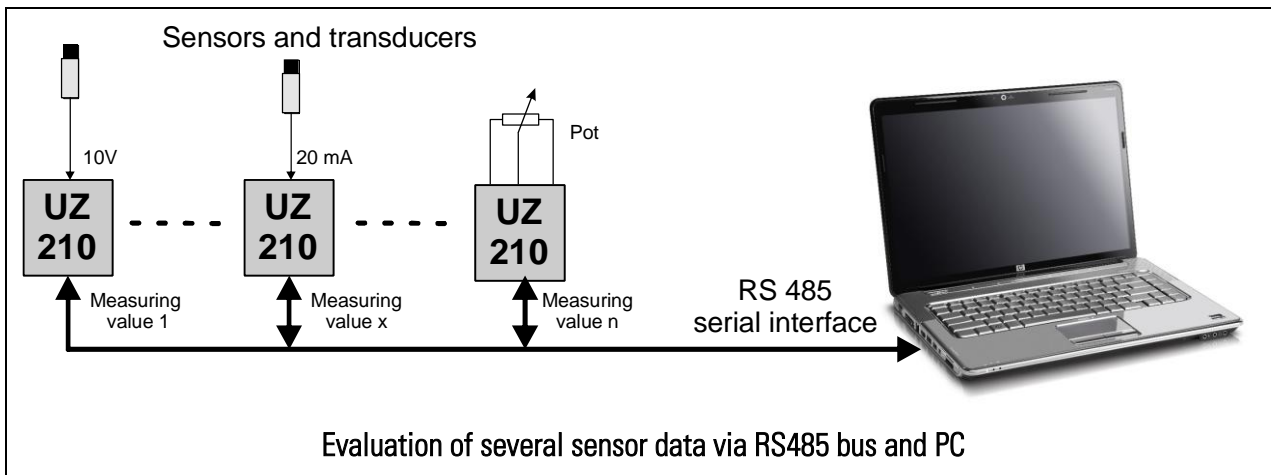

4. Connections and Control Elements

For electrical connection the unit provides four plug-in terminal strips **X1**, **X3**, **X4** and **X5**, with mechanical codification against accidental misconnection. The 9-position Sub-D-connector **X2** and the front USB port provide communication and PC setup of the unit.

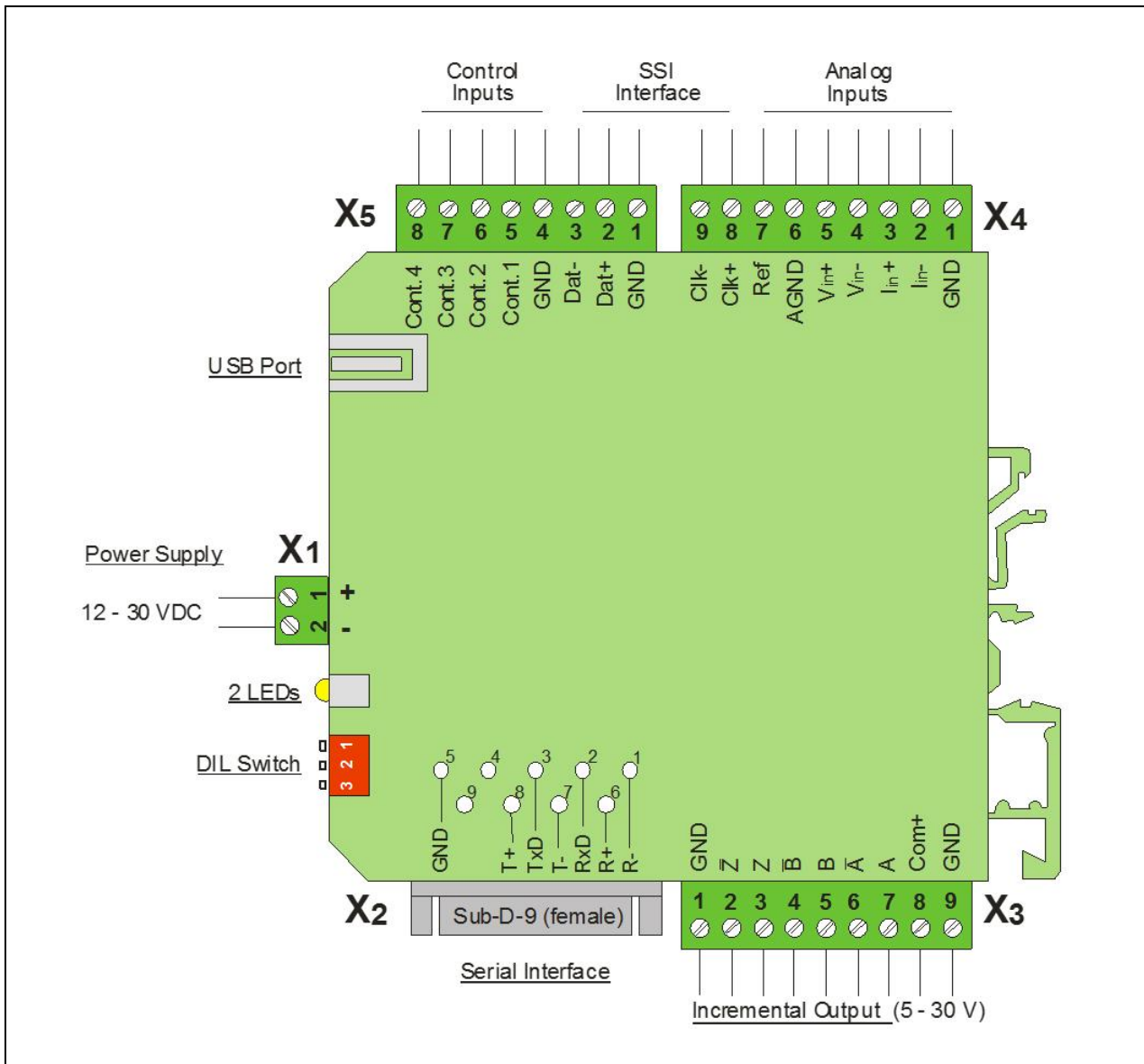

4.1. Power Supply

The UZ 210 converter requires a DC supply from 12 to 30 VDC applied to the screw terminals **X1** [1] (+) and **X1** [2] (-) (residual ripple $\leq 0,5$ V). In idle state the typical consumption is approx. 50 mA (24 VDC input). The green front LED indicates that power is applied to the unit.

4.2. Control Inputs Control1 - Control4

Four control inputs with programmable function are accessible via terminals **X5** [5, 6, 7, 8]. The desired function can be assigned by the parameters [Input Config.] and [Input Function] of the „Command Setting“ menu.[a]

All control inputs are designed as PNP inputs, i.e. a positive voltage must be applied with reference to GND. The switching thresholds are $LOW \leq 3\text{ V}$ and $HIGH \geq 10\text{ V}$, and the input impedance is about $15\text{ k}\Omega$.

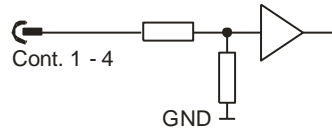

Principal of a control input circuit

4.3. The SSI Interface

A synchronous serial interface according to the industrial SSI standard is available on terminal strips **X4** and **X5**, for absolute signal transmission of positions or angles. In SSI operating mode the converter acts exactly like an SSI absolute encoder, i.e. it receives a clock signal from a remote Master via lines **X4** [8] (Clk+) and **X4** [9] (Clk-), and it sends the corresponding data via lines **X5** [2] (Dat+) and **X5** [3] (Dat-).

Please note that the unit will not provide any internal termination resistors. [b]

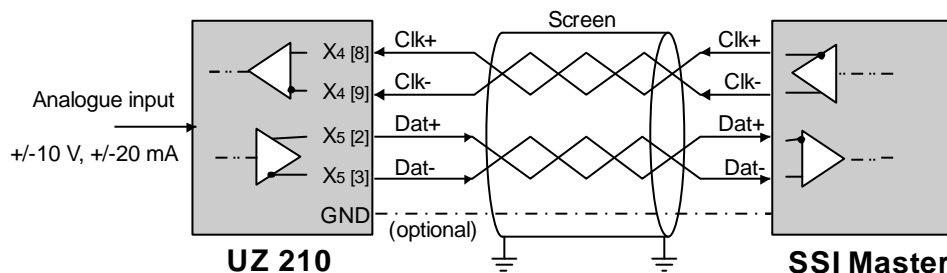

Connection of the SSI interface to a remote SSI Master (position controller, PLC or similar)

[a] See chapter [5.5](#)

[b] For recommendations about screening and signal termination please refer to the document “General Rules for Wiring, Screening and Earthing” available under the Support section of our website.

4.4. Analogue Inputs

The differential inputs on the input side of the converter accept standard voltages ($\pm 10\text{ V}$), standard currents (0/4 - 20 mA) and also potentiometer connection. The drawings below explain the principle of the input circuits with each of the input connection modes.

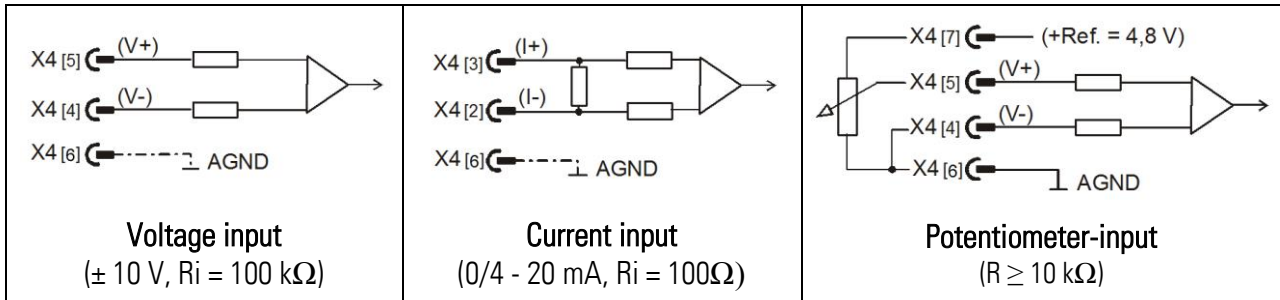

4.5. Incremental Outputs

A complete set of incremental channels A, /A, B, /B, Z and /Z is available for incremental representation of the analogue input signal. Inverted channels are for optional use and may remain unconnected if not needed (e.g. for transmission at a 24 volts impulse level with use of channels A and B only). Likewise also the marker pulse outputs Z and /Z may remain open when the application does not provide zero pulse evaluation.

Dependent on the respective Mode of Operation of the converter the incremental output signals represent either a frequency proportional to the analogue input signal (i.e. straight analogue-to-frequency conversion), or a linear or angular position (i.e. for applications with analogue linear scales or analogue angular transducers).

All output lines are equipped with push-pull drivers (short-circuit-proof) and the output swing (signal level) results from the remote voltage applied to terminal X3 [8]. Upon non-connection of this terminal the unit automatically generates a 4 volts TTL-compatible output.

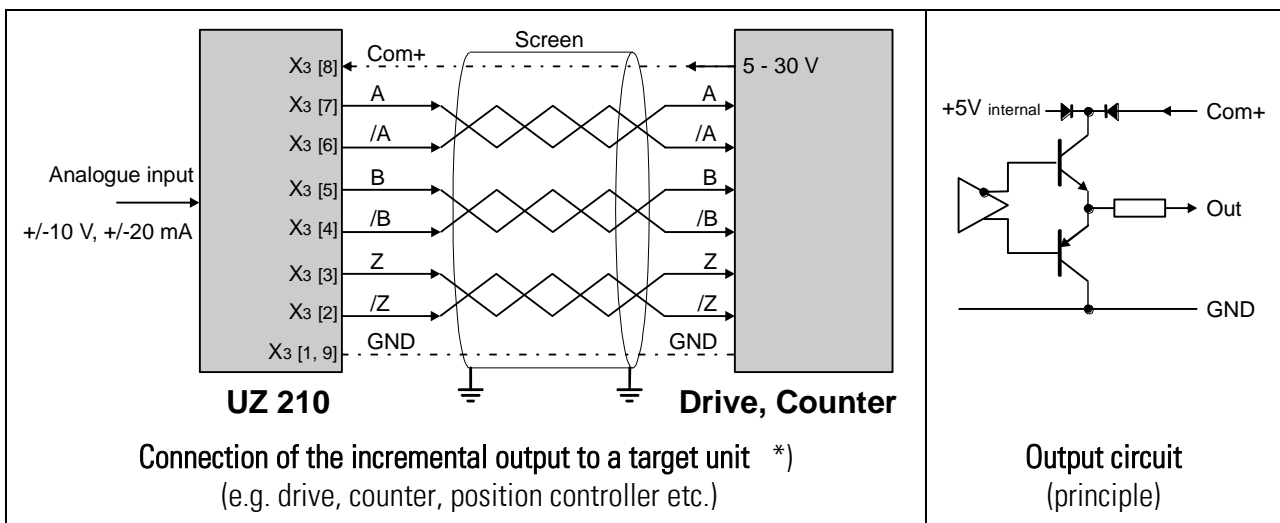

*) For recommendations about screening and signal termination please refer to the document "General Rules for Wiring, Screening and Earthing" available under the Support section of our website.

4.6. The Serial Interface

Both, a serial RS 232 interface and a RS 485 interface are available on the unit; however the converter can only communicate by one or by the other interface, but not by both at a time. Serial communication allows readout of internal measuring and conversion results and is also required for setup and commissioning of the unit via PC.

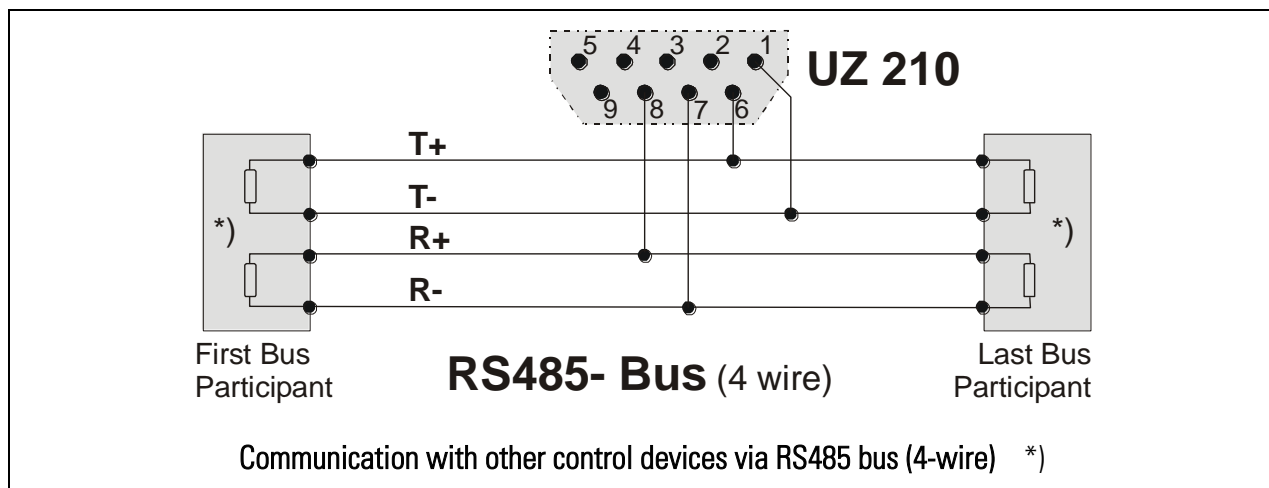
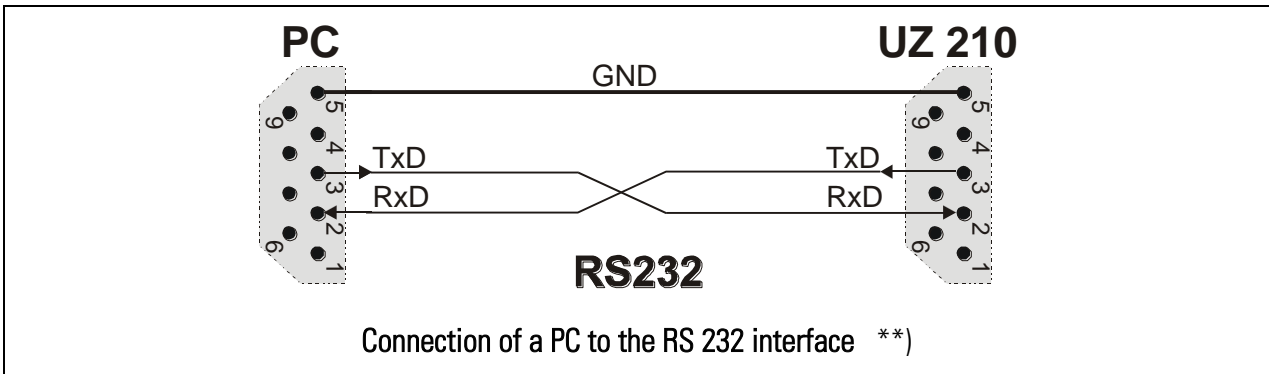
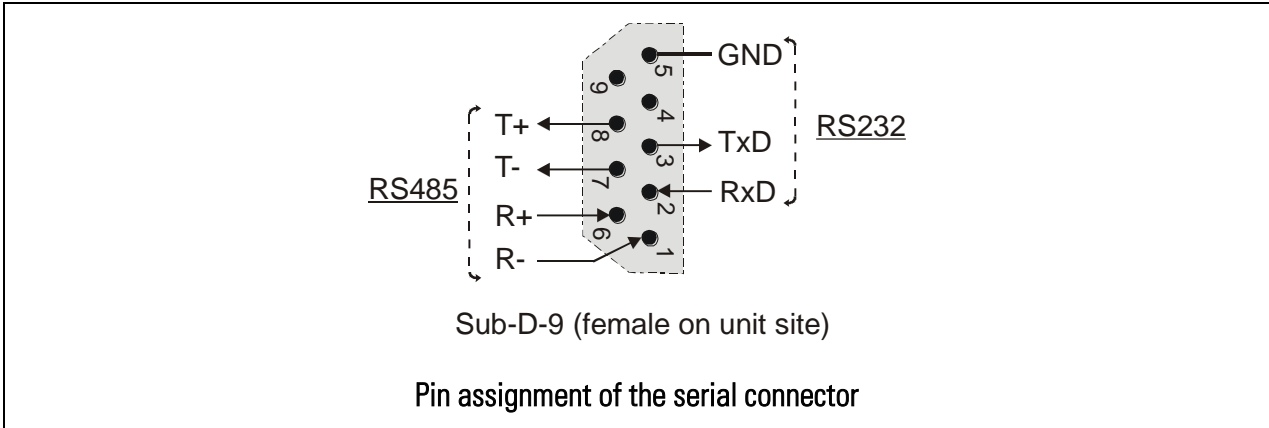

*) For recommendations about screening and signal termination please refer to the document "General Rules for Wiring, Screening and Earthing" available under the Support section of our website.

***) Please connect only pins 2, 3 and 5 as shown. Connection of the other pins (e.g. by using a fully occupied 9-conductor cable) will cause problems with communication.



Where both, RS232 and RS485 interface are in use, you can communicate by the one or by the other, but not by both interfaces at the same time.

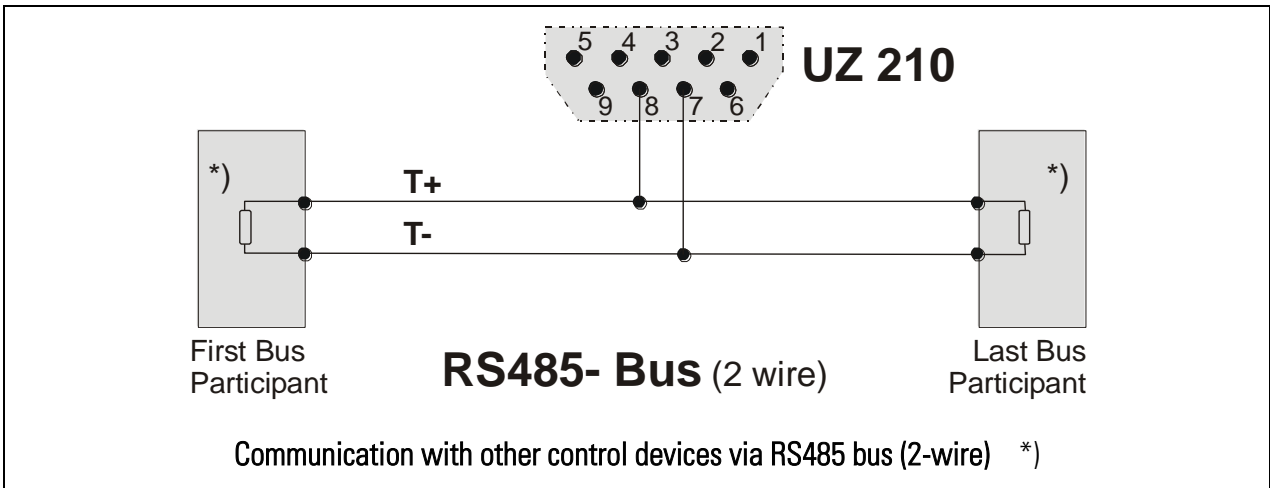

*) For recommendations about screening and signal termination please refer to the document "General Rules for Wiring, Screening and Earthing" available under the Support section of our website

4.7. The USB Communication Port

For connection of the converter to a PC via USB a connection cable with "type A" connectors on both sides is required (A-A-cable, available in Electronic Shops or from motrona).

Special hints for operation of the USB port can be found in chapter [7](#).



4.8. The Front DIL Switch and the Front LEDs

The 3-position DIL switch located on the front side provides the following settings:

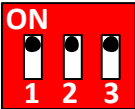
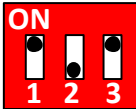
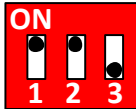
		
<p><u>Normal Operation</u></p> <p>For normal operation of the converter all positions of the switch must be ON at any time.</p>	<p><u>Reload Default Settings</u></p> <p>Upon next power-up all parameters will be overwritten by the factory default values.</p>	<p><u>Programming-Mode</u></p> <p>For factory use only, e.g. to download a new firmware version to the unit</p>

DIL switch settings are read once upon power up of the unit only. It is therefore important to cycle the power supply after any change of DIL switch settings, in order to activate the corresponding function.

The green LED on the front indicates that DC power is applied to the unit. The yellow LED remains OFF first after powering the unit up, then turns on after initialization of the processor, to indicate that the converter is ready for operation.

5. Parameter Settings

For setting of parameters and commissioning a PC with Operator Software OS32 is required. Please connect your PC to the unit via USB cable (see [4.7](#) and [7](#)) or by serial link (see [4.6](#)). After starting the OS32 software the following screen will appear:

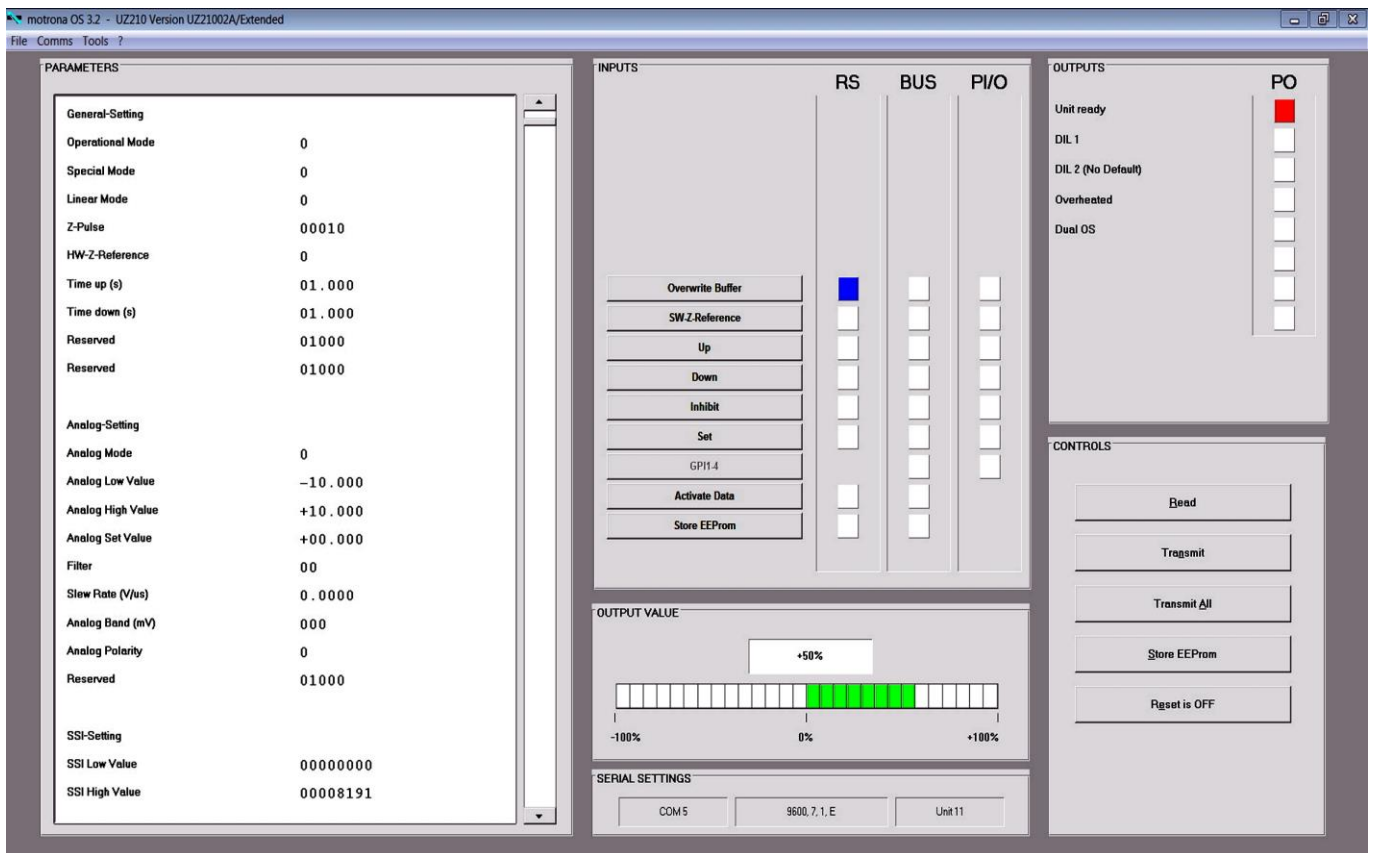

Where you find the parameter field empty with the top line indicating "OFFLINE", please click to the "Comms" menu in the head line to adapt the serial communication parameters of your PC correspondingly.

The parameter field allows to read and to edit all unit parameters according to need. The subsequent parameter tables explain the function and setting of each parameter in detail. The tables also inform about the factory default settings and the serial access codes of all parameters.



- It is possible to operate both, the serial interface and the USB port simultaneously.
- Special hints for serial communication can be found in chapter [6](#).
- Special hints for USB communication and for simultaneous operation of both communication ports can be found in chapter [7](#).

5.1. General Settings

No.	Parameter Description	Range	Default	Ser.
001	Operational Mode: 0: Analogue input => Frequency (incremental output) 1: Analogue input => Position (incremental output) [a] 2: Analogue input => Position (incremental output) [a] 3: Analogue input => Position (SSI interface)	0, 1, 2, 3	0	A0
002	Special Mode: 0: standard operation as a signal converter 1: Function as „Motorized Potentiometer“ (frequency and position generator, keys „UP“ and „DOWN“) 2: Repeat-Function (cyclic course of frequency or position curves)	0, 1, 2	0	A1
003	Linear Mode: Programmable Linearization [b] 0: Linearization OFF 1: Linearization in the positive range only (negative input values appear as a mirror of positive values) 2: Full range linearization of positive and negative inputs	0, 1, 2	0	A2
004	Z-Pulse: Number of increments between 2 marker pulses When this parameter is set to a value “n”, the converter generates an index output pulse after every “n” encoder impulses	5 - 60 000	10	A3
005	HW-Z-Reference: Hardware Reference for marker pulse Parameter to define the function of control input [Cont1] 0: Free function assignment to [Cont1] Parameter 032 [Input 1 Function] assigns the function to the control input [Cont1] 1: a static HIGH signal on input [Cont1] will reset the marker pulse counter to zero (re-initialization) [c] 2: a rising edge on input [Cont1] will reset the marker pulse counter to zero (re-initialization) [c] 3: a falling edge on input [Cont1] will reset the marker pulse counter to zero (re-initialization) [c]	0, 1, 2, 3	0	A4
006	Time up: Ramp time for UP commands (increase output with motorized potentiometer and repeat functions)	0,001 - 99,999 sec	1,000	A5
007	Time down: Ramp time for DOWN commands (decrease output with motorized potentiometer and repeat functions)	0,001 - 99,999 sec	1,000	A6
008	Reserved, no function			
009	Reserved, no function			

[a] Mode 1 uses a fixed time raster of 100 µsec. causing a possible minimum output frequency of 10 kHz. Mode 2 uses variable input sampling and therefore can also generate frequencies lower than 10 kHz with slow changes of the input position

[b] See chapter [5.8](#)

[c] Input „Cont1“ is now reserved for this function only and no more available for other assignments, i.e. it is mandatory to set parameter [Input1 Function] to “0”.

5.2. Analogue Settings (Analogue Input)

No.	Parameter Description	Range	Default	Ser.
010	Analogue Mode: Input characteristics 0: Input signal = voltage (± 10 V) 1: Input signal = current (0/4 - 20 mA)	0, 1	0	A9
011	Analogue Low Value: Beginning of the analogue range	$\pm 10\,000$ mV	-10 000	B0
012	Analogue High Value: End of the analogue range	$\pm 10\,000$ mV	+10 000	B1
013	Analogue Set Value: Preset value for the analogue input *)	$\pm 10\,000$ mV	0	B2
014	Analogue Filter: Filter function for the analogue input (used for smoothing of unstable analogue input signals) 00: Filter OFF (immediate response) 01: Filter LOW, fast response (T ca. 50 μ sec) --- 05: Filter MEDIUM, medium response (T ca. 800 μ sec) --- 12: Filter HIGH, very slow response (T ca. 100 msec)	0 - 12	0	B3
015	Analogue Slew Rate: Limitation of the dynamic slope of analogue input signals to a maximum value according to setting	0 - 1,0000 V/ μ sec	0	B4
016	Analogue Band: Dead band for signal changes The output will only respond to changes of the analogue input if they are greater than the dead band setting	0 - 100 mV	0	B5
017	Analogue Polarity: positive or negative frequencies 0: The direction information A/B (90°) will change according to input signal and parameter setting 1: All impulse outputs are in forward direction only (A always leading B), no reverse frequencies (This setting is not relevant with „Operational Mode = 3“, SSI)	0, 1	0	B6
018	Reserved, no function			

5.3. SSI Setting (SSI Data Transmission)

No.	Parameter Description	Range	Default	Ser.
019	SSI Low Value: Beginning of the SSI output value where the analogue input equals to „Analogue Low Value“	1 - 33554431 (25 Bit)	0	B8
020	SSI High Value: End of the SSI output value where the analogue input equals to „Analogue High Value“	1 - 33554431 (25 Bit)	8191 (13 Bit)	B9
021	SSI Format: Coding of the SSI signal 0: Output data is Gray coded 1: Output data is binary coded	0, 1	0	C0
022	SSI Baud Rate: SSI transmission speed	0,001 - 1,000 MHz	0,100	C1
023	SSI Bit: Resolution, total length of one SSI telegram	10 - 25 Bit	25	C2
024	Reserved, no function			

*) see parameter No. 032 [Input1 Function]

5.4. Encoder Setting (Incremental Output)

No.	Parameter Description	Range	Default	Ser.
025	POS Low Value: Beginning of the position count where the analogue input equals to „Analogue Low Value“	±100 000 000 (increments)	0	C4
026	POS High Value: End of the position count where the analogue input equals to „Analogue High Value“	±100 000 000 (increments)	10 000	C5
027	FRE Low Value: Start value of the frequency where the analogue input equals to „Analogue Low Value“	± 1 000 000.00 (Hz)	-1000.00	C6
028	FRE High Value: End value of the frequency where the analogue input equals to „Analogue High Value“	± 1 000 000.00 (Hz)	+1000.00	C7
029	Reserved, no function			
030	Reserved, no function			

5.5. Command Setting (Control Inputs)

No.	Parameter Description	Range	Default	Ser.
031	Input 1 Config: Switching characteristics of input „Cont1“ 0: Function active with static LOW level 1: Function active with static HIGH level	0, 1	0	D0
032	Input 1 Function: Function of input „Cont 1“ 0: no function assigned 1: Function „Set“. Forces the analogue input temporary to the fixed value according to the setting of [Analogue Set Value] (see parameter Nr. 013) 2: Function „Inhibit“. Disables temporary all changing at the analog input and freeze the last value 3: Function „DOWN“. Down-function (decrease value) with motorized potentiometer applications 4: Funktion „UP“. Up-function (increase value) with motorized potentiometer applications 5: Function „Z-Reference“. Assigns a static Reset function for the marker impulse counter *) 6: Function „Print“. The input will trigger a serial transmission of the specified measuring value.	0 - 6	0	D1
033	Input 2 Config: see „Input 1 Config“	0, 1	0	D2
034	Input 2 Function: see „Input 1 Function“	0 - 6	0	D3
035	Input 3 Config: see „Input 1 Config“	0, 1	0	D4
036	Input 3 Function: see „Input 1 Function“	0 - 6	0	D5
037	Input 4 Config: see „Input 1 Config“	0, 1	0	D6
038	Input 4 Function: see „Input 1 Function“	0 - 6	0	D7
039	Reserved, no function			
040	Reserved, no function			

*) Function only suitable for slow and purely static Reset (e.g. for index referencing in standstill).
For dynamic requirements please refer to parameter 005 [HW-Z-Reference]

5.6. Serial Setting (RS232/RS485 Interface)

No.	Parameter Description	Range	Default	Ser.
041	Unit Number (serial device address)	11 ... 99	11	90
042	Serial Baud Rate (communication speed) 0 = 9600 Bauds 1 = 4800 Bauds 2 = 2400 Bauds 3 = 1200 Bauds 4 = 600 Bauds 5 = 19 200 Bauds 6 = 38 400 Bauds 7 = 56 000 Bauds 8 = 57 600 Bauds 9 = 76 800 Bauds 10 = 115 200 Bauds	0 - 10	0	91
043	Serial Format (byte format of serial data) 0 = 7 Data, Parity even, 1 Stop 1 = 7 Data, Parity even, 2 Stop 2 = 7 Data, Parity odd, 1 Stop 3 = 7 Data, Parity odd, 2 Stop 4 = 7 Data, no Parity, 1 Stop 5 = 7 Data, no Parity, 2 Stop 6 = 8 Data, Parity even, 1 Stop 7 = 8 Data, Parity odd, 1 Stop 8 = 8 Data, no Parity, 1 Stop 9 = 8 Data, no Parity, 2 Stop	0 ... 9	0	92
044	Serial Protocol (transmit protocol with Printer-Mode *) 0 = Transmission = Unit No. – Data, LF, CR 1 = Transmission = Data, LF, CR	0 ... 1	0	E0
045	Serial Timer (setting for timed transmissions (sec.) *)	0.000 ... 9.999	0	E1
046	Register Code (serial register code of the transmit value *)	0 ... 19	16	E2
047	Reserved, no function			
048	Reserved, no function			
049	Reserved, no function			

*) More information about serial operation of the unit can be found in chapter 6.

5.7. Linearization Setting

No.	Linearization Table	Range	Default	Ser.
050	First interpolation point (x0, original value)	-10 000 ... +10 000	0	E6
051	First interpolation point (y0 as substitution for x0)			...
052	Second interpolation point (x1, original value)			...
053	Second interpolation point (y1 as substitution for x1)			...
	etc. ---->			...
080	Last interpolation point (x15, original value)			...
081	Last interpolation point (y15 as substitution for x15)			H7

5.8. Hints for Use of the Linearization Function

The drawings below explain the difference between the settings „Linear Mode“ = 1 and „Linear Mode“ = 2:

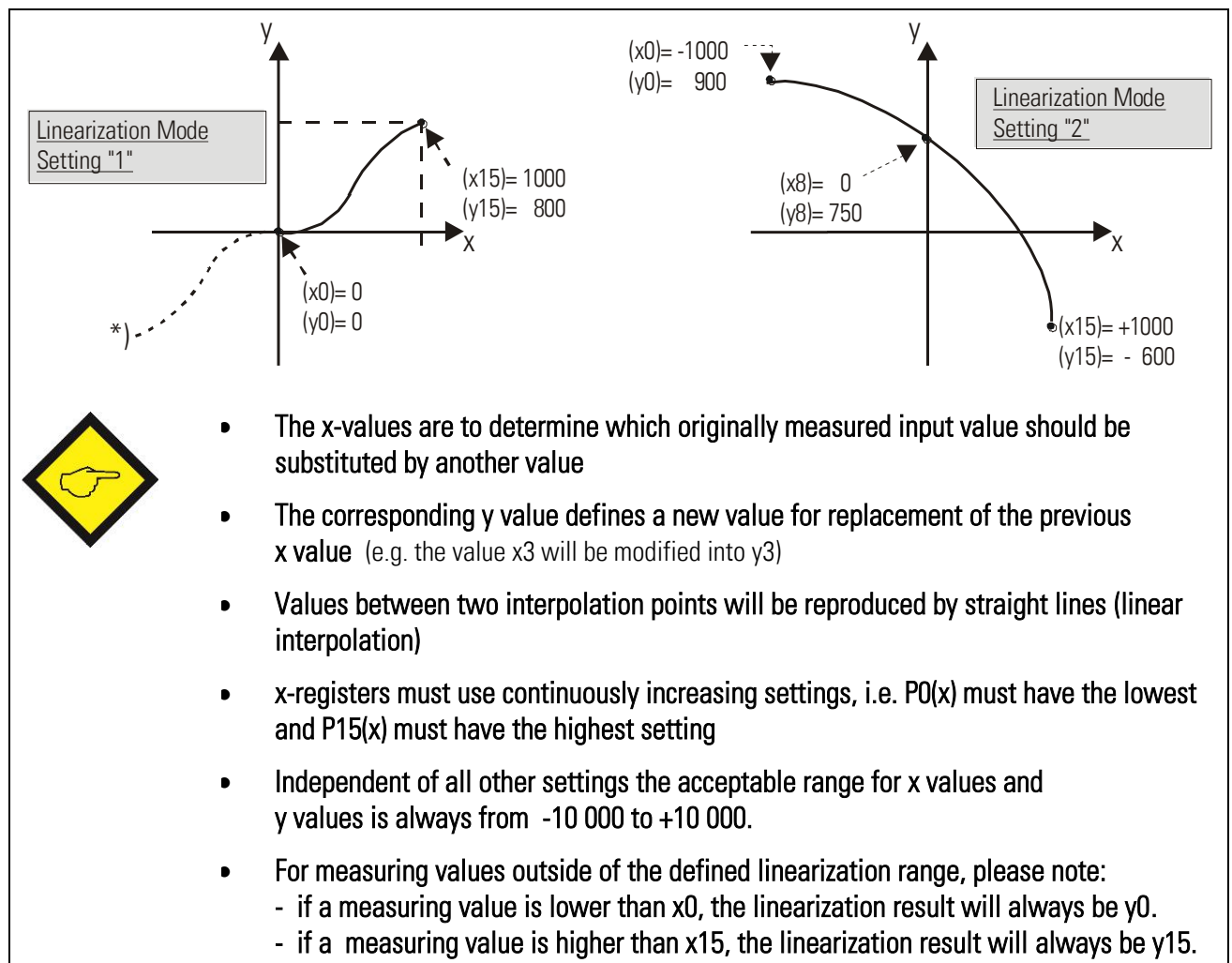

6. Hints for Serial Communication

Serial communication with the UZ210 converter is intended to be used for

- **Setup and programming of the unit by PC with operator software OS32**
(see chapter 5)
- **Automatic and cyclic transmission of converter data to a PC or PLC or data logger**
- **Free communication with PC or PLC using the communication protocol**

This chapter describes the most essential communication functions only. For more detailed and general information please refer to the special document "SERPRO".

6.1. Automatic and Cyclic Data Transmission

Set any cycle time unequal to zero to parameter [Serial Timer]. Set the serial access code of the register you would like to transmit to parameter [Register Code]. In theory you could transmit any of all available internal register values by serial link, however in the current case only the following register makes really sense:

Parameter „Register Code“	Code internal	Value for transmission
16	;6	Analogue input value, scaled in mV

Depending on the setting of parameter [Serial Protocol] the unit transmits one of the following two strings (xxxx = Converter Data, LF = Line Feed [hex. 0A], CR = Carriage Return [hex 0D])
(Leading zeros will not be transmitted)

	(Unit No.)											
Serial Protocol = 0 :	1	1	+/-	X	X	X	X	X	X	LF	CR	
Serial Protocol = 1 :			+/-	X	X	X	X	X	X	LF	CR	

6.2. Communication Protocol

When communicating with the unit via protocol, you have full read/write access to all internal parameters, states and actual values. The protocol uses the DRIVECOM standard according to DIN ISO 1745. The serial access codes of all parameters can be found in the parameter description (see chapter 5).

To request data from the unit, the following request string must be sent:

EOT	AD1	AD2	C1	C2	ENQ
EOT = control character (Hex 04) AD1 = unit address, High Byte AD2 = unit address, Low Byte C1 = register code to read, High Byte C2 = register code to read, Low Byte ENQ = control character (Hex 05)					

The table below shows how to request the actual analogue input data (register code ;6) from a converter with the serial unit number 11:

ASCII-Code:	EOT	1	1	;	6	ENQ
Hexadecimal:	04	31	31	3B	36	05
Binary:	0000 0100	0011 0001	0011 0001	0011 1011	0011 0100	0000 0101

Upon correct receipt of the request string the unit will respond:

STX	C1	C2	x x x x x x x	ETX	BCC
STX = control character (Hex 02) C1 = register code to read, High Byte C2 = register code to read, Low Byte xxxxx = data (measuring value) ETX = control character (Hex 03) BCC = block check character					

Leading zeros will not be transmitted. The block check character BCC is composed by an EXCLUSIVE-OR function of all characters from C1 up to and including ETX.

To write parameter data to the unit the following data string must be sent:

EOT	AD1	AD2	STX	C1	C2	x x x x x x x	ETX	BCC
EOT = control character (Hex 04) AD1 = unit address, High Byte AD2 = unit address, Low Byte STX = control character (Hex 02) C1 = register code to write data, High Byte C2 = register code to write data, Low Byte xxxxx = data, new parameter value ETX = control character (Hex 03) BCC = Block check character								

Upon correct receipt the unit will respond by ACK, otherwise by NAK.

Every new parameter sent will first wait in a buffer memory, without affecting the actual converter function. This feature enables the user, during normal converter operation, to prepare a complete new parameter set in the background.

To activate transmitted parameters you must write the numeric value "1" to the [Activate Data] register. This immediately activates all changed settings at the same time.

Where you like the new parameters to remain valid also after the next power up of the unit, you still have to write the numeric value "1" to the [Store EEPROM] register. This will store all new data to the EEPROM of the unit. Otherwise, after power down the unit would return with the previous parameter settings.

Function	Code
Activate Data	67
Store EEPROM	68

Both commands provide dynamic operation, i.e. it is enough to just send "1" to the corresponding location. After execution the command will reset to zero automatically.

Example: send [Activate Data] to the converter with unit number 11:

ASCII	EOT	1	1	STX	6	7	1	ETX	BCC
Hex	04	31	31	02	36	37	31	03	33

7. Hints for Operation of the USB Port

Prior to using the USB port it is mandatory to store the driver file „**motrona_vcom.inf**“ in a user-defined directory of the PC (any directory according to your own choice will be fine). The driver file is available for download from the SUPPORT section of the motrona website www.motrona.com.

After the very first USB connection between PC and converter the Plug-and-Play-Function of the PC will first try to find a suitable driver via Internet. You are free to either abort the internet search or to just wait for the message “no suitable driver found”. After this, please follow the subsequent steps to install the driver manually:

- Click to **Start**, select **Control Panel** and from there choose **Device Manager**. Among other devices the device manager will now indicate one unit named **Motrona_UZ210xx** (Fig. 1).
- Double-click to **Motrona_UZ210_xx** and choose **Update Driver** (Fig. 2)
- Now select **Browse my computer for driver software**. Then select exactly the folder to where before you have saved the **motrona_vcom.inf** driver file. In our example the driver has been stored on drive D in the folder **MOTRONA\Motrona_Software\driver** (Fig. 3 and 4).
- After assignment of the driver, the USB Port will be configured as a communication interface and the number of the Virtual Com Port attached by the system is shown on the screen (in our example this is COM 5, see Fig. 5).
- Now we are ready to start the OS32 Operator software. Please select first the „Coms“ menu of the OS32 software to set the communication parameters correspondingly (Fig. 6).

USB communication between converter and PC has now successfully been installed and the OS32 Operator Software is ready to work.



- When two OS32 Operator Software programs are running at the same time (one via USB and the other via serial), the indicator box **Dual OS** of the **OUTPUTS** column will be ON (this indication responds with a short delay).
- In the **Inputs** field both columns, **RS** and **BUS** will now be active. Column **RS** indicates all commands released by the PC actually in use, and column **BUS** indicates all commands released by the other (remote) OS32 Software. At any time column **PI/O** indicates the logical state of the hardware command inputs of the unit.
- It is possible to disable parameter settings and changes coming from the other (remote) OS32 software. This can be achieved by setting the command **Overwrite Buffer** to ON. When switched ON, the commands „Activate Data“ and „Store EEPROM“ of the second communication channel will be suppressed. This is to ensure that parameter settings can happen only by the PC currently used, and no undesirable modifications will get in from the other (remote) communication port.
- **Whenever two PC's run the OS32 software simultaneously, it is important to never enter the Test menu from any of the two sides!**

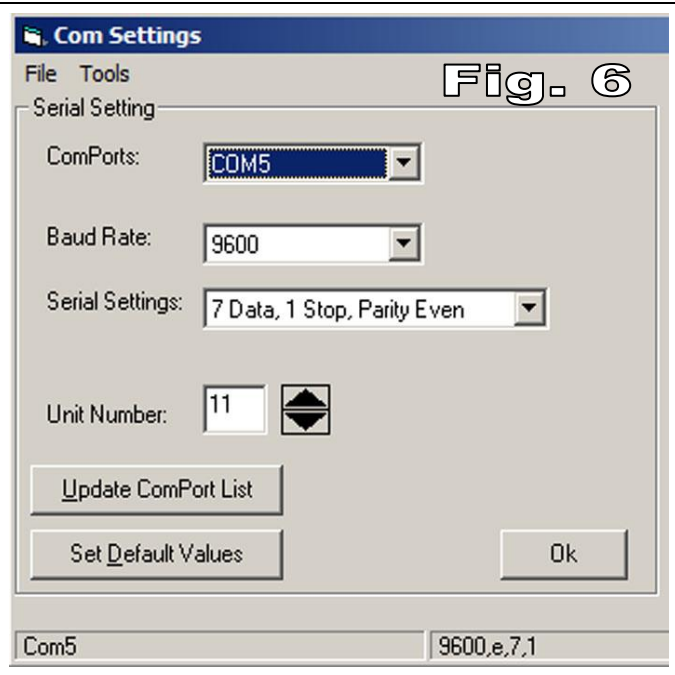
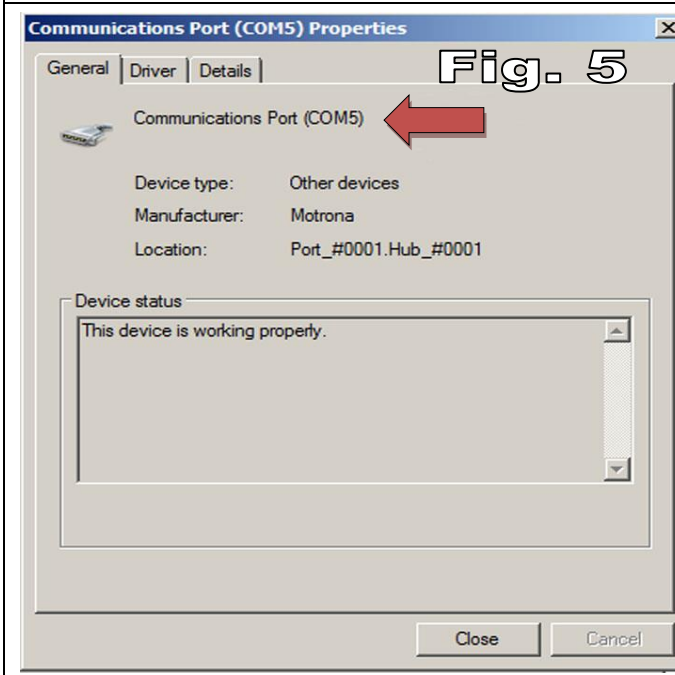
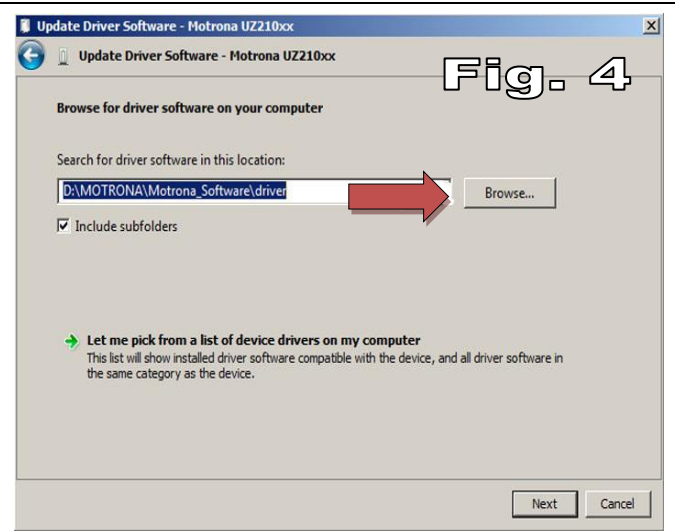
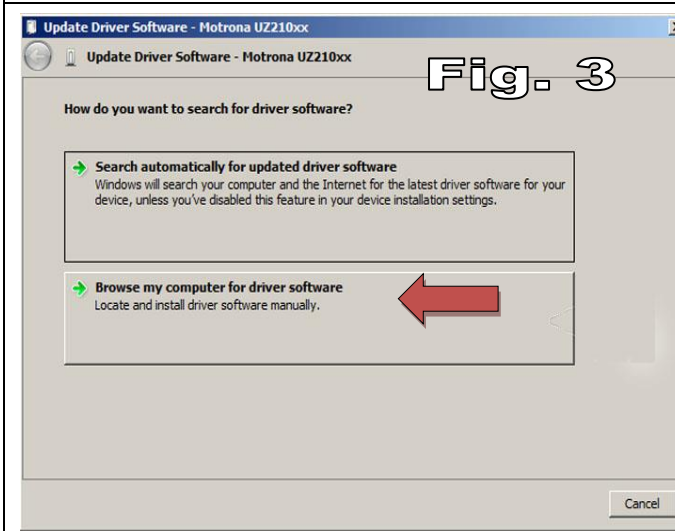
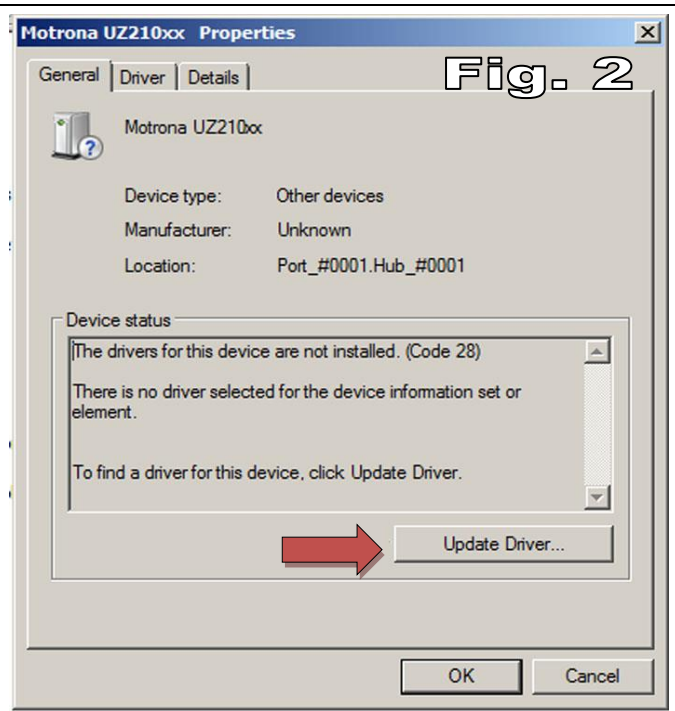
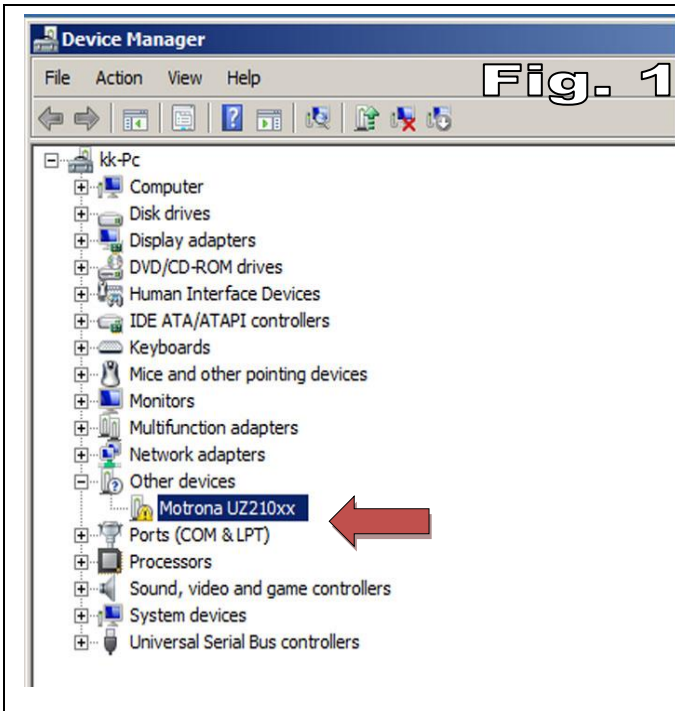

8. Technical Specifications

Power supply:	Input voltage: 12 ... 30 VDC Protection circuit: reverse polarity protection Ripple: $\leq 10\%$ at 24 VDC Consumption: approx. 50 mA (unloaded) Connections: screw terminal, 1.5 mm ² / AWG 14
Analog input:	Voltage input: -10 ... +10 V / 0 ... 10 V Internal resistance: $R_i \approx 120\text{ k}\Omega$ Current input: 0 ... 20 mA / 4 ... 20 mA Internal resistance: $R_i \approx 100\ \Omega$ Resolution: 14 bit (± 13 bit) Accuracy: 0.1 % Update-time: 100 μ s (in accordance to 10000 measuring values per second) max. Input frequency: 1 kHz (with 10 sampling points) VREF for external potentiometer: approx. 4.8 V (+/- 0.1%) Internal VREF resistance: $R_i \approx 240\ \Omega$ Connections: screw terminal, 1.5 mm ² / AWG 14
Control inputs:	Number of inputs: 4 Characteristic: PNP, active high Signal levels: HTL: LOW = 0 ... 3 V, HIGH = 10 ... 30 V Internal resistance: $R_i \approx 1.5\text{ k}\Omega$ Input current: approx. 2 mA Minimum pulse time: 1 msec (5 μ s at Cont.1 when [HW-Z-Reference] $\neq 0$) Connections: screw terminal, 1.5 mm ² / AWG 14
Incremental output:	Signal levels: HTL: 5 ... 30 V (depends from the external supply) or TTL / RS422: 4 V (no external supply necessary) Channels: A, /A, B, /B, Z, /Z Frequency range: 0.01 Hz ... 1 MHz Output current: max. 30 mA (per channel) Output circuit: push-pull Reaction time: < 260 μ s Fastest position change possibility: 1 increment / μ s Protection circuit: short circuit proof Connections: screw terminal, 1.5 mm ² / AWG 14
SSI interface:	Function: simulates an SSI absolute encoder Standard: according to the SSI standard, 10 ... 25 bit, binary or Gray (supports only single transmission but not multiple-transmission) Clock (input): TTL-differential / RS485 [Clk+], [Clk-] Data (output): TTL-differential / RS485 [Dat+], [Dat-] Termination resistors: internally not provided SSI baud rate: max. 1 MHz Connections: screw terminal, 1.5 mm ² / AWG 14
Serial interface:	Format: RS232 or RS485 (2- or 4-wire) Baud rates: 600, 1200, 2400, 9600 (Default), 19200, 38400, 56000, 57600, 76800 and 115200 Connections: SUB-D connector (female), 9-pin
USB interface:	Version: USB 2.0 Driver: motrona_vcom.inf (download on www.motrona.com) Connections: by USB-Port, connector type „A

Continuation "Technical Specifications"

Housing:	Material: plastic Mounting: 35 mm top hat rail (according to EN 60715) Dimensions (w x h x d): 22.5 x 102 x 102 mm Protection class: IP20 Weight: approx. 100 g
Temperature range:	Operation: 0 °C ... +45 °C / +32 ... +113 °F (not condensing) Storage: -25 °C ... +70 °C / -13 ... +158 °F (not condensing)
Conformity & standards:	EMC 2004/108/EC: EN 61000-6-2, EN 61000-6-3, EN 61000-6-4 RoHS 2011/65/EU: EN 50581

9. Dimensions

